

# EXPOSURE DRAFT

---

## **NEW BUSINESS TAX SYSTEM (CONSOLIDATION) BILL 2002**

---

### EXPLANATORY MATERIAL

(Circulated by authority of the Minister for Revenue and Assistant Treasurer,  
Senator the Hon Helen Coonan, MP)



---

# ***Table of contents***

---

Glossary .....	1
General outline and financial impact .....	3
Chapter 1 Overview of consolidation.....	5
Chapter 2 Core rules .....	19
Chapter 3 Membership rules .....	33
Chapter 4 Asset rules .....	65
Chapter 5 Transferring losses to a consolidated group.....	119
Chapter 6 Determining whether a transferred loss can be used by a consolidated group.....	141
Chapter 7 Limiting the use of transferred losses by a consolidated group .....	149
Chapter 8 Transitional concessions for losses .....	167
Chapter 9 Franking accounts in consolidated groups .....	175
Chapter 10 Resident wholly-owned subsidiaries of a common foreign holding company.....	181
Chapter 11 Interaction with international provisions.....	215
Chapter 12 Consolidated groups with life insurance companies .....	221
Chapter 13 Removal of grouping provisions .....	231
Index .....	239



---

# Glossary

---

The following abbreviations and acronyms are used throughout this explanatory material.

<i>Abbreviation</i>	<i>Definition</i>
<i>A Platform for Consultation</i>	Review of Business Taxation: <i>A Platform for Consultation</i>
<i>A Tax System Redesigned</i>	Review of Business Taxation: <i>A Tax System Redesigned</i>
ADF	approved deposit fund
CFC	controlled foreign company
CGT	capital gains tax
Commissioner	Commissioner of Taxation
COT	continuity of ownership test
December 2000 exposure draft	New Business Tax System (Consolidation) Bill 2000 exposure draft
GDP	gross domestic product
ESAS	Employee Share Acquisition Scheme
FBT	fringe benefits tax
FIF	foreign investment fund
GIC	general interest charge
ITAA 1936	<i>Income Tax Assessment Act 1936</i>
ITAA 1997	<i>Income Tax Assessment Act 1997</i>
ITRA 1986	<i>Income Tax Rates Act 1986</i>
MEC	multiple entry consolidated
PAYG	pay as you go
PDF	pooled deposit fund
PST	pooled superannuation trust
RSA	retirement savings account
SAP	substituted accounting period
SBT	same business test
TAA 1953	<i>Taxation Administration Act 1953</i>
Thin Capitalisation legislation	<i>New Business Tax System (Thin Capitalisation) Act 2001</i>



---

# ***General outline and financial impact***

---

## **Consolidated groups**

This exposure draft contains rules for the introduction of a consolidation regime for certain wholly-owned entity groups. The accompanying explanatory material also contains a discussion of proposed rules that are not contained in the exposure draft. Broadly, the consolidation regime will:

- allow wholly-owned groups of entities to make a choice to consolidate and therefore be treated as a single entity for the purposes of determining income tax liability;
- set out rules for determining the cost (for income tax liability purposes) of assets, including membership interests, in relation to consolidated groups;
- describe the circumstances in which losses of a consolidated group may be transferred to the head company of a consolidated group and how those losses may subsequently be used by the head company;
- set out rules for the transfer of franking credits to consolidated groups;
- allow certain groups with a single non-resident head company to form a consolidated group;
- address the interaction of the consolidation regime with international provisions;
- provide special rules for the treatment of consolidated groups with life insurance companies as members; and
- remove certain existing grouping provisions, including those allowing transfer of losses between wholly-owned company groups and the intercorporate dividend rebate.

***Date of effect:*** Wholly-owned entity groups will be allowed to choose to consolidate under this scheme from 1 July 2002. The existing grouping provisions will generally cease to apply as of 1 July 2002. Special rules apply in the case of a consolidated group with a head company with a SAP. In general, such SAP groups will retain access to grouping provisions until the date of consolidation, provided that the head company chooses to consolidate from the first day of their next income year commencing after 1 July 2002.

***Proposal announced:*** The proposals were announced in Treasurer's Press Release No. 58 of 21 September 1999 (in particular, refer to Attachment E).



---

# **Chapter 1**

## **Overview of consolidation**

---

### **Outline of explanatory material**

1.1 Where a consolidated group is formed, the group is treated as a single entity for income tax purposes. Broadly, this means that the subsidiary entities lose their individual income tax identities and are treated as parts of the head company of the consolidated group (rather than separate entities) for the purposes of determining income tax liability during the period in which they are members of the group.

1.2 The purpose of this explanatory material is to provide an overview of the consolidation regime as a whole. This chapter contains a brief summary of each of the significant aspects of the regime, including matters that are not addressed by the law contained in the exposure draft release. Matters which are not so included are also the subject of individual chapters later in the explanatory material. A discussion of each of these measures is also provided as a guide to the content and policy intent of the proposed law.

1.3 The consolidation regime will apply primarily to a wholly-owned group of Australian resident entities that choose to form a consolidated group for income tax purposes. In general, such a group must be wholly-owned by an Australian resident company. It is proposed that eligible wholly-owned groups will be able to choose to form a consolidated group as from 1 July 2002.

1.4 Chapter 2 deals with the core rules of consolidation, such as the single entity rule, and their consequences. Chapter 3 explains the rules dealing with the formation and membership of a consolidated group, including rules about the types of entities that are eligible to join, and making the choice to form a consolidated group.

1.5 The subsequent chapters deal with other specific rules necessary for the implementation of the consolidation regime, including:

- setting of the cost of assets (including membership interests);
- transferring and utilising losses relating to a pre-consolidation period;
- transfer of franking credits and franking accounts in consolidated groups;

- rules relating to resident wholly-owned subsidiaries of foreign holding companies ('MEC groups');
- treatment of attribution accounts and foreign tax credits;
- consolidated groups with members that are life insurance companies; and
- removal, cessation or modification of other grouping provisions under the ITAA 1997, including loss transfer provisions, intercorporate dividend rebate CGT asset rollover and certain foreign tax credit grouping provisions.

1.6 The general principles for taxation of consolidated groups – single entity rule, membership, setting of cost bases and treatment of losses – were contained in the December 2000 exposure draft. The rules contained in this exposure draft have since been redrafted to take into account submissions following the release of that draft law. Those rules have also been restructured and streamlined to improve their presentation.

1.7 In summary, this explanatory material discusses:

- streamlined and redrafted rules on matters which were the subject of the December 2000 exposure draft and which are included in this exposure draft;
- rules contained in the December 2000 exposure draft which are currently in the process of streamlining and restructuring;
- proposed rules on key aspects which were not contained in the December 2000 exposure draft and included in the current exposure draft; and
- proposed rules on key aspects which were not contained in the December 2000 exposure draft and are not included in the current exposure draft.

1.8 Accordingly, where a chapter of this explanatory material contains no legislative references, no draft law accompanies the topic in the exposure draft.

## **Context of reform**

1.9 To promote business efficiency, as well as tax system integrity, *A Tax System Redesigned* recommended that groups of wholly-owned entities be permitted to choose to be taxed as a single entity rather than on an entity by entity basis. It is proposed to introduce a legislative regime which gives effect to that recommendation.

1.10 The existing grouping provisions of the ITAA 1997 and the ITAA 1936 (such as those relating to loss transfer and CGT rollover relief for asset transfers) and the intercorporate dividend rebate allow groups of companies to obtain the benefits of single entity treatment for some purposes. In other respects, however, the income tax system continues to require each entity to account separately for intra-group transactions and intra-group debt and equity interests.

1.11 Consolidation will address both efficiency and integrity problems existing in the taxation of wholly-owned entity groups, many of which arise from this inconsistent treatment. These include:

- compliance and general tax costs;
- double taxation where gains are taxed when realised and then taxed again on the disposal of equity;
- tax avoidance through intra-group dealings;
- loss cascading by the creation of multiple tax losses from the one economic loss; and
- value shifting to create artificial losses where there is no actual economic loss.

1.12 These problems will be addressed by ceasing to recognise multiple layers of ownership within a wholly-owned group and by treating wholly-owned groups as a single entity for income tax purposes.

1.13 The consolidation regime will therefore:

- assist in the simplification of the tax system;
- reduce both compliance costs and tax revenue costs associated with the existing tax treatment of company groups;
- improve the efficiency of business restructuring; and
- strengthen the integrity of the income tax system.

## **Comparison of key features of new law and current law**

1.14 The following table summarises the key differences between the proposed tax treatment of consolidated groups and the treatment of wholly-owned groups under the current law.

<i>New law</i>	<i>Current law</i>
A consolidated group is taxed as a single entity.	Each entity in a wholly-owned group is taxed as a separate entity.
All intra-group transactions are ignored.	Only some intra-group transactions are ignored (e.g. certain asset transfers under CGT rollover).
Consolidation, and therefore grouping, is available to both wholly-owned company groups and groups which include trusts and other entities as subsidiaries of the parent company.	The current grouping provisions are only available to wholly-owned groups of companies.
Gains realised within a consolidated group are recognised only once.	There is the potential for the double taxation of economic gains.
Losses realised within a consolidated group are recognised only once.	There is the potential for the duplication and cascading of losses. Loss integrity measures apply when there has been substantial duplication.
Losses, franking credits and foreign tax credits of the group are pooled.	Losses and foreign tax credits can be transferred within a wholly-owned corporate group. Franking credits stay with the company that derived them.
Resident wholly-owned groups will be able to form a consolidated group despite the fact that the group's single head company is a non-resident.	A resident wholly-owned group of a non-resident head company is able to access current grouping concessions.
The special rules that apply to tax life insurance companies will apply to the head company of a consolidated group if that consolidated group has one or more members that are life insurance companies.	Life insurance companies are taxed according to special rules, but on an individual entity basis.
Grouping rules no longer apply to wholly-owned groups. Wholly-owned groups that do not consolidate have no equivalent rules outside of consolidation.	Wholly-owned groups of companies may use grouping rules such as the intercorporate dividend rebate, loss transfer provisions and CGT rollover relief.

## Summary of new law

<i>Core rules</i>	Chapter 2
<i>Membership rules</i>	Chapter 3
<i>Asset rules</i>	Chapter 4
<i>Transferring losses to a consolidated group</i>	Chapter 5
<i>Determining whether a transferred loss can be used by a</i>	Chapter 6

<i>consolidated group</i>	
<i>Limiting the use of transferred losses by a consolidated group</i>	Chapter 7
<i>Transitional concessions for losses</i>	Chapter 8
<i>Franking accounts in consolidated groups</i>	Chapter 9
<i>Resident wholly-owned subsidiaries of a common foreign holding company</i>	Chapter 10
<i>Interaction with international provisions – pooling of foreign tax credits and treatment of attribution accounts</i>	Chapter 11
<i>Life insurance companies</i>	Chapter 12
<i>Removal of grouping provisions: intercorporate dividend rebate, loss transfers (including retention for branches of foreign banks); removal of CGT asset rollover relief; removal of excess foreign tax credit transfers; thin capitalisation adjustments</i>	Chapter 13

1.15 The consolidation regime implements a set of recommendations made in *A Tax System Redesigned*. Those recommendations have led to the development of a set of rules that provide the basis on which groups are permitted to consolidate and be treated as a single entity for tax purposes. The regime is underpinned by rules for the setting of cost of assets according to the asset-based model discussed in *A Platform for Consultation* and recommended by *A Tax System Redesigned*.

1.16 The following overview highlights and explains the component parts of the consolidation regime, including (where necessary) summaries of the approach proposed to be adopted with respect to each of those elements. The discussion proceeds in the order set out in the previous heading, *Summary of new law*.

## Core rules

### *Single entity rule*

1.17 Following a choice to consolidate, a group of eligible wholly-owned entities is treated as a single entity for the purposes of working out its income tax liability and/or losses. The subsidiary entities lose their individual income tax identity on entry into a consolidated group and are treated as part of the head company (the single entity rule).

1.18 Consequences of the single entity rule for the purposes of working out the group's income tax liability and/or losses during consolidation include:

- the head company of the group lodges a single consolidated income tax return, removing the need for provision of income tax returns by individual subsidiary members;
- the assets and liabilities of the subsidiary members are treated as if they were assets and liabilities of the head company;
- the actions of the subsidiary members (e.g. acquisition or disposal of assets) are treated as if they had been undertaken by the head company; and
- intra-group transactions are ignored.

### ***Clean slate rules***

1.19 Things that happened to a subsidiary entity before it joined the group cannot be attributed to the head company for the purposes of working out its income tax liability or losses (entry clean slate rule). Similarly, when subsidiaries exit the group, they do so with a fresh income tax identity, so things that happened to them before they joined or while they were a member of a group cannot generally be taken into account in working out their post-consolidation income tax liability or losses (exit clean slate rule). The clean slate rules are currently being reviewed (see paragraphs 2.35 to 2.41).

### ***Asset rules***

1.20 The assets of the subsidiary entity, by virtue of the single entity rule applying during consolidation, are treated as assets of the head company. Chapters 2 and 4 discuss specific provisions that treat the assets as having:

- a new acquisition date, being the joining time; and
- a new cost, worked out by reference to the head company's cost of acquiring the subsidiary.

1.21 A group's cost of acquiring a subsidiary entity is treated as its cost of acquiring the assets of that entity. Rules apply when an entity leaves a group that preserve the alignment between the group's cost for membership interests in the entity and its assets.

## **Membership rules**

1.22 Chapter 3 explains the rules dealing with the formation of a consolidated group, including rules dealing with the types of entities that are eligible to join such a group. It also explains the proposed notification requirements that will apply when an entity becomes or ceases to be a member of a pre-existing consolidated group.

1.23 Entry into the consolidation regime is generally restricted to those groups who have a resident holding company (head company) at the head of the group in order to give practical meaning to the concept of a single Australian taxpayer. This means, for example, that wholly-owned groups in Australia that do not have a common Australian holding company between the non-resident parent and the Australian resident subsidiaries are unable to form a consolidated group under the ordinary membership rules. However, such groups may be eligible to form a MEC group. Rules relating to the formation and income tax treatment of MEC groups are discussed in Chapter 10.

1.24 Broadly, membership is restricted to an ordinary Australian resident holding company and all of its eligible resident wholly-owned companies, trusts and partnerships.

1.25 The broad rationale underlying the rules that limit the types of entities that are eligible to be a member of a consolidated group is to ensure that consolidated groups receive a tax treatment like ordinary Australian resident companies and that relative concessional treatment is neither effectively gained by nor denied to entities by becoming a member of a consolidated group.

1.26 Although consolidation is optional, if a group consolidates, all of the holding company's eligible resident wholly-owned companies, trusts and partnerships, including entities acquired in the future, must be included in the consolidated group.

1.27 A decision to enter into the consolidation regime is irrevocable. Consistent with this principle are rules to ensure that a consolidated group will generally continue to exist whilst the head company remains eligible to be a head company.

## **Asset rules**

1.28 The rules deal with assets of subsidiary entities which join or leave a consolidated group.

1.29 The acquisition or disposal of an entity by a consolidated group is treated like the acquisition or disposal of the assets of that entity. A group's cost of acquiring a subsidiary entity is treated as the cost of acquiring the subsidiary's assets. When a subsidiary entity ceases to be a member of the group, the group is recognised as having acquired the membership interests in the subsidiary for an amount equal to the group's cost for the net assets of that entity.

1.30 The alignment of costs for assets with costs for membership interests within a consolidated group prevents the double taxation of gains and duplication of losses and allows for assets to be transferred between members of the consolidated group without requiring cost base adjustments to address value shifting.

1.31 Groups that form on or before 30 June 2003 can elect to retain a subsidiary's existing costs for assets where the subsidiary is a wholly-owned subsidiary of the head company from 1 July 2002 until the formation of the group. Where this election is made the entry clean slate rule will not apply in respect of that subsidiary entity.

## **Losses**

1.32 Chapters 5 to 8 deal with the transfer to and utilisation of losses by a consolidated group. When an entity becomes a member of a consolidated group, its unused carry forward losses are tested to determine whether they can be transferred to the group. Broadly, a loss can only be transferred to the head company of a consolidated group if the loss could have been used outside the group by the entity seeking to transfer it.

1.33 The utilisation of losses transferred to a consolidated group is not to exceed a certain limit. The loss factor method sets that limit on the utilisation of transferred losses by reference to the contribution to group income expected to be made by the entity that transferred the losses.

1.34 A concessional method for the use of transferred losses has been developed to apply to certain losses transferred to a consolidated group in the transitional period. A further transitional concession is provided in recognition that, under the existing group loss transfer rules, an entity can use its losses to shelter not just its own income but also the income of another member of the same wholly-owned group.

## **Franking accounts in consolidated groups**

1.35 Chapter 9 sets out special imputation rules that apply to consolidated groups. During the period of consolidation, the head company of the group will be a franking entity for the purposes of the imputation rules. The head company will maintain a single franking account for the consolidated group and subsidiary members will have dormant franking accounts during the period in which they are members of a consolidated group. At the time at which a subsidiary member joins a consolidated group, any surplus in its franking account is to be transferred to the head company's franking account. If, however, the subsidiary's franking account is in deficit at the joining time, the subsidiary will be liable to pay franking deficits tax.

1.36 During the period that a subsidiary is a member of a consolidated group, any franking credits or debits that would otherwise have arisen in the franking account of the subsidiary member (i.e. were it not a member of a consolidated group with a dormant account) are attributed to the franking account of the head company.

1.37 The rules also deal with the franking of distributions by a subsidiary member of a consolidated group to shareholders because those



shareholders hold certain shares known as disregarded ESAS shares. These shares are disregarded for the purpose of eligibility for membership of a consolidated group.

## **MEC (multiple entry consolidated) groups**

1.38 Chapter 10 contains rules which allow certain resident wholly-owned subsidiaries of a foreign company to be treated as a consolidated group (MEC groups, or MECs). Without this measure, wholly-owned resident subsidiaries of a foreign resident company would not be able to form a consolidated group unless they were restructured. The aim of this measure is to ensure that existing company groups that currently have access to grouping provisions (e.g. loss transfer and CGT rollover) will be able to form a consolidated group despite not having a single resident head company.

1.39 A MEC group consists of all the eligible tier-1 companies of a 'top' company and all the resident entities that are wholly-owned subsidiaries of those eligible tier-1 companies. Broadly, an eligible tier-1 company is the entity that is a foreign company's first tier of investment into Australia. A MEC group can be formed either by a choice being made to form a group or as a result of a consolidated group converting into a MEC group.

1.40 One of the eligible tier-1 companies in the MEC group will be treated as the head company of the group. The remaining members of the MEC group will be treated as subsidiary members of the group. The head company of the MEC group is responsible for the final income tax obligations of the group and will hold the losses, franking credits and other tax attributes of the group.

1.41 Chapter 10 also discusses other rules (yet to be released) that apply to MEC groups, relating to matters such as:

- the treatment of assets held by MEC group members; and
- the treatment of membership interests in eligible tier-1 companies.

## **Interaction with international provisions**

### *Transfer of foreign tax credits*

1.42 The proposed measures discussed in Chapter 11 will require the excess foreign tax credit balances held by each of the members of a wholly-owned group that chooses to consolidate to be transferred to the head company. The excess credits will be transferred at the time the choice to consolidate takes effect. Where an entity joins a consolidated group its excess credits will be transferred to the head company at the joining time. The head company can pool all the transferred-in excess

credits with its own excess credits according to the class of income and the income year in which the credits arose.

1.43 There will be limitations that mirror the current foreign tax credit provisions on the use of excess foreign tax credits by the head company that have been transferred to it by subsidiary members.

1.44 If an entity pays foreign tax on foreign income during the period in which it is a member of the consolidated group, the head company will be assessed on the foreign income and will be deemed to have paid the foreign tax.

*No transfers to an entity leaving a group*

1.45 Where an entity leaves a consolidated group it will not have any excess foreign tax credit balance at the time of leaving. Any foreign tax paid while it was a member of the group will not give rise to an excess credit for the entity that left the group but may give rise to a credit for the head company.

1.46 Following the introduction of consolidation, the transfer of excess foreign tax credits will no longer be available between members of a wholly-owned group that has not consolidated. This is consistent with the intended choice between either consolidation or individual income tax treatment. This is further discussed in Chapter 13, which deals with grouping provisions.

*Transfer of attribution account and attributed tax account surpluses*

1.47 The proposed measure will provide that an entity that becomes a subsidiary member of a consolidated group will transfer to the head company the attribution surpluses, FIF attribution surpluses, attributed tax account surpluses and FIF attributed tax account surpluses at the time it joins a consolidated group. These accounts record amounts that are subject to current year taxation under the CFC and FIF measures and are used to ensure the amounts are not taxed again on distribution. The measure will apply at the time a consolidated group comes into existence as well as for entities joining an existing consolidated group. The amount of the surplus to be transferred will be calculated at the formation or joining time.

1.48 Any attribution account debits or credits that would otherwise arise in a subsidiary member's attribution or attributed tax accounts arise instead in the head company's accounts as the head company will be the only entity that can operate the relevant accounts. The subsidiary member's accounts will be dormant while it is a member of the consolidated group.

*For an entity that leaves a consolidated group*

1.49 Where an entity leaves a consolidated group with an interest in an FIF or CFC it will be able to take a proportion (based on the percentage of the group's interest in the CFC or FIF held by the leaving entity) of the head company's attribution surplus and/ or attributed tax account surplus at the time it leaves the consolidated group. The amount of the surplus to be transferred is to be calculated at the leaving time.

1.50 This is a departure from a general principle of the consolidation regime that when an entity leaves a consolidated group tax attributes remain with the group. Nevertheless the departure is justified because a surplus in the attribution accounts can only benefit an entity that holds an interest in a CFC or FIF. Accordingly, a consolidated group would not be able to benefit from an attribution account surplus to the extent that the leaving entity has the interest in the CFC or FIF.

### **Consolidated groups with life insurance companies**

1.51 Chapter 12 discusses the provisions that will apply specifically to life insurance companies in consolidated groups. These provisions will ensure that the head company of a consolidated group that has one or more life insurance company members will be treated as a life insurance company for taxation purposes.

1.52 This gives effect to the single entity principle in a way that preserves the recommendations relating to life insurance companies in *A Tax System Redesigned*. Under those recommendations, life insurance companies segregate assets relating to complying superannuation business (which is taxed at the rate of 15%) and immediate annuity business (which is exempt from tax). In addition, to ensure amounts are taxed at the correct rate, certain transactions between the segregated assets and the ordinary part of their business are taxable events.

1.53 As a consequence of treating the head company of a consolidated group that has one or more life insurance company members as a life insurance company for taxation purposes, the special taxation rules that apply to life insurance companies will apply to the head company so that:

- certain statutory income of life insurance companies is included in the assessable income of the head company;
- certain exempt income of life insurance companies is exempt income of the head company;
- certain specific deductions of life insurance companies are allowable deductions of the head company;

- the rules that apply to the segregated virtual PST assets and segregated exempt assets of life insurance companies apply to the head company;
- the dividend imputation rules that apply to life insurance companies apply appropriately to the head company; and
- the provisions of the ITRA 1986 that apply to life insurance companies apply to the head company so that the head company will be taxed at a rate of 15% on the complying superannuation class of its taxable income.

1.54 In addition:

- the rules relating to the segregated assets of life insurance companies will apply jointly to all members of the consolidated group that are life insurance companies;
- the virtual PST component of the complying superannuation class of taxable income will be worked out as if the life insurance company was not a member of the consolidated group;
- as a consequence of the special rules for taxing life insurance companies, the rules that apply to the treatment of the assets of an entity that joins or leaves a consolidated group will be modified where that joining or leaving entity is a life insurance company; and
- for a joining or leaving entity that is a life insurance company, the value of liabilities relating to the net risk components of life insurance policies and the net investment component of ordinary life insurance policies will be prescribed.

### **Removal of grouping provisions**

1.55 Chapter 13 deals with the removal of various existing grouping provisions in the ITAA 1997 and ITAA 1936. The current grouping provisions permit wholly-owned company groups to secure some of the benefits of single entity treatment by allowing tax concessions within wholly-owned groups. The intention is to provide a choice between complete consolidation or ordinary individual tax treatment, rather than to maintain the existing hybrid system as represented by the current grouping provisions. Groups that choose not to consolidate will be governed by loss integrity and anti-value shifting measures in relation to intra-group transactions.

1.56 The current grouping provisions will in general, cease to apply from the commencement of the consolidation regime on 1 July 2002.

1.57 In summary:

- shareholder companies will not be entitled to the intercorporate dividend rebate under sections 46 and 46A of the ITAA 1936 in respect of dividends paid or net income derived;
- in general, the loss transfer provisions in Subdivisions 170-A, 170-B and 170-C of the ITAA 1997 will cease to have effect for all wholly-owned groups. The loss transfer provisions will, however, be retained in a modified form for transfers involving Australian branches of foreign banks;
- rollover relief under Division 126 of the ITAA 1997 for transfers of CGT assets within a wholly-owned group will cease;
- section 160AFE of the ITAA 1936 will be repealed, to the extent that it deals with transfers of foreign tax credits between members of a group; and
- the consolidation regime will essentially replace the grouping rules contained in the Thin Capitalisation legislation which applies to a taxpayer's first income year commencing on or after 1 July 2001.

1.58 The removal of each of the measures mentioned in paragraph 1.57 will be delayed in the case of consolidated groups with SAP groups. In general, SAP groups that make an election to consolidate from the first day of their next income year commencing after 1 July 2002 will retain access to the grouping concessions in their current form up until that date.

## **Application and transitional provisions**

1.59 The consolidation regime applies from 1 July 2002.

## **Consequential amendments**

1.60 Amendments consequential to the measures discussed in this chapter will be included in subsequent legislation.



---

# Chapter 2

## Core rules

---

### Outline of chapter

2.1 This chapter explains the core rules of the consolidation regime, comprising the:

- single entity rule;
- clean slate rules; and
- treatment of assets.

2.2 The rules are contained in Part 3-90 of Division 701 to the ITAA 1997.

### Context of reform

2.3 Taxing groups as single entities addresses problems associated with the taxation of wholly-owned groups, identified in *A Tax System Redesigned*, such as:

- *tax impediments to business organisation* – for example, compliance costs and possible tax costs of liquidating a redundant company in a wholly-owned group;
- *high compliance costs* – for example, the costs of dealing with the tax implications of intra-group dividends;
- *double taxation* – where gains realised in ordinary commercial transactions are taxed again on the disposal of equity;
- *tax avoidance through intra-group dealings* – for example, manipulating dealings between group companies to reduce or defer tax;
- *loss cascading* – where group companies (as well as companies that are less than 100% owned) can use a chain of companies to create multiple tax losses based on one initial economic loss; and
- *loss duplication* – where losses realised in carrying on a business or on disposal of assets are realised again on the disposal of equity.

2.4 Following the recommendations in *A Tax System Redesigned*, the single entity treatment, coupled with the clean slate rules and special rules

for setting the cost base of assets of entities joining and leaving consolidated groups, will:

- simplify the tax system and reduce ongoing compliance costs;
- promote economic efficiency by providing a taxation framework that allows Australian businesses to adopt organisational structures based more on commercial rather than tax considerations; and
- promote equity by improving the integrity of the tax system.

## **Summary of new law**

2.5 Following a choice to consolidate, a group of eligible wholly-owned entities is treated as a single entity for the purposes (core purposes) of working out its income tax liability or losses. Subsidiary entities lose their individual income tax identity on entry into a consolidated group and are treated as parts of the head company.

2.6 Consequences of the single entity treatment for working out the group's income tax liability or losses during consolidation include:

- the group lodges a single consolidated income tax return, removing the need for provision of income tax returns by individual subsidiary members;
- the assets and liabilities of the subsidiary members are treated as if they were assets and liabilities of the head company;
- the actions of the subsidiary members (e.g. acquisition or disposal of assets) are treated as if they had been undertaken by the head company; and
- intra-group transactions are ignored.

2.7 Things that happened to a subsidiary entity before it joined the group cannot be attributed to the head company for the purposes of working out its income tax liability or losses (entry clean slate rule). Similarly, when subsidiaries exit the group, they do so with a fresh income tax identity, so things that happened to them before they joined or while they were a member of a group cannot generally be taken into account in working out their post-consolidation income tax liability or losses (exit clean slate rule).



2.8 The entry clean slate rule will not apply in respect of a subsidiary where the head company elects on formation of the consolidated group to adopt the transitional option of using the entity's 'terminating value' for its assets. The rationale for such treatment is to allow groups to consolidate during the transitional period without having to undertake market valuations of all assets of subsidiary members of the group.

2.9 While a subsidiary is part of a consolidated group, its assets are treated as assets of the head company. Specific provision is made to treat the assets as having:

- a new acquisition date, being the entity's joining time; and
- a new cost, worked out by reference to the head company's cost of acquiring the subsidiary.

2.10 Rules that preserve the alignment between the head company's cost for membership interests in the entity and the entity's cost of assets apply when an entity leaves a group.

2.11 Immediately before any entity leaves a consolidated group, the head company is deemed to have acquired the membership interests in the leaving entity for a payment that reflects the group's cost of the net assets of the leaving entity.

2.12 On leaving, the entity is treated as having acquired the assets it takes from the group for a payment for each asset that, if received by the group, would generally be a tax-neutral disposal by the group.

## Comparison of key features of new law and current law

<i>New law</i>	<i>Current law</i>
A consolidated group is treated as a single entity.	Each entity in a wholly-owned group is taxed as a separate entity.
Intra-group transactions will attract neither tax consequences nor compliance consequences for a consolidated group.	Only some intra-group transactions will escape tax consequences (e.g. CGT rollover relief is available for some assets but not revenue assets). All intra-group transactions will attract compliance costs.

## Detailed explanation of new law

### The single entity rule

2.13 The income tax treatment of a consolidated group flows from the rule that an entity is treated as part of the head company while it is a

subsidiary member of a consolidated group. Actions of the subsidiaries are treated as actions of the head company, as this is the only entity the income tax law recognises for the purposes of working out the income tax liability or losses of a consolidated group. For example, a transfer of an asset from one subsidiary member to another is treated like a transfer from one division of a company to another division. As such, such a transaction could not have any tax consequences for these purposes, as no disposal between distinct entities would have occurred (an entity cannot transact with itself). [*Schedule 1, item 1, section 701-1*]

2.14 The single entity rule will ensure that the ITAA 1997 and the ITAA 1936 operate in respect of a consolidated group as if the subsidiaries are absorbed into the head company, which is the relevant taxpayer. A number of implications flow from the application of this rule.

### ***Consequences of the single entity rule***

#### *Accounting and returns*

2.15 The consolidated group will:

- lodge a single income tax return, with no separate lodgment requirements imposed on its members;
- keep a consolidated franking account;
- pool losses, franking credits and foreign tax credits brought into a consolidated group; and
- effectively maintain a common tax accounting period for all its member entities.

#### *Intra-group transactions*

2.16 Transactions between members of a consolidated group will be ignored for income tax purposes. For example, payment of management fees between group members will not be deductible or assessable for income tax purposes. In addition, intra-group dividends will not be assessable or subject to the franking regime.

2.17 Assets can therefore be transferred between member entities without tax consequences. This removes the need to adhere to formal CGT rollover arrangements and depreciation balancing adjustment relief. Similarly, there will be no need to undertake cost base adjustments following transactions that may otherwise be subject to the value shifting provisions of the ITAA 1997. Shares in a group company can be bought back without the possibility of triggering a capital gain or loss. A group company can be liquidated without the possibility of triggering either a deemed dividend or a capital gain or loss.

---

*Treatment of assets*

2.18 The assets, liabilities, etc of the subsidiary member are treated for income tax purposes as if they were owned by the head company, as this is the only entity the income tax law recognises.

*Liability*

2.19 In general, the head company will be liable for the income tax debts of the consolidated group that are referable to the period of consolidation. Special rules will be developed to deal with the recovery of income tax debts from subsidiary members where the head company defaults on its primary obligation.

*Other consequences of the single entity rule*

2.20 Some examples of the effect of absorption of the subsidiaries into the head company (for the purposes of working out its income tax liability or losses) are that during consolidation:

- the taxable income of the taxpayer under section 4-15 of the ITAA 1997 refers to that of the head company. This calculation is made on the basis that income and deductions are assessed or allowable under the ITAA 1997 to the head company only;
- a provision such as section 262A of the ITAA 1936 (which refers to record keeping requirements) should be read as requiring the head company to adopt those obligations in so far as they relate to the assessment of its income tax liability. Under the single entity rule, those obligations rest with the head company as it is regarded as the taxpayer during the period of consolidation;
- for the purpose of determining any relevant income tax consequences arising out of the holding or disposal of assets:
  - the head company is taken to acquire any assets that a member entity held at entry or acquires while a member of the group;
  - the head company is taken to hold any assets for so long as they are held by an entity while it is a subsidiary member of the group and to do anything in relation to those assets that is done by the subsidiary member;
  - if a CGT event happens in relation to any CGT assets held by any entity while a subsidiary member of the group, that event is taken to happen in relation to the asset while held by the head company and anything done by the subsidiary entity as part of the CGT event is taken to have been done by the head company; and

- the trading stock that is sold between members of the same wholly-owned group will no longer be recognised as trading stock but will be treated as consumables. This is because, following consolidation, intra group transactions are ignored for income tax purposes.

***Things not affected by the single entity rule***

2.21 Only income tax matters relating to the income tax activities of member entities while they are part of a consolidated group are currently embraced by the single entity rule. [*Schedule 1, item 1, section 701-1*]

2.22 This means that obligations or rights that relate to assessments of income tax in respect of periods prior to a subsidiary joining a consolidated group remain with that subsidiary. Any rights or obligations of a subsidiary in relation to an income tax assessment before the entity joined a consolidated group continue to operate notwithstanding that the subsidiary has become a member of a consolidated group. For example, a subsidiary may pursue an objection in relation to an assessment of income tax for a pre-consolidation period at any time while it is in a consolidated group.

2.23 Only income tax obligations are comprehended by the single entity rule. For example, obligations such as FBT liability continue, as does a withholding obligation of the subsidiary under the ITAA 1936 or under the TAA 1953 while the subsidiary entity is a member of a consolidated group. An entity's obligation to collect the income tax payable by a third party is not related to working out that entity's income tax liability or losses. Therefore, an entity's withholding obligations relating to the tax payable by a third party continues despite the entity being a subsidiary member of a consolidated group.

***Characterisation of assets and transactions***

2.24 Following an election to consolidate, the single entity rule has the effect that in assessing the income tax position of the head company, the head company is taken to hold all the assets and liabilities of its subsidiaries and to enter into the transactions of its subsidiaries for the purposes of determining that income tax position. This is because the subsidiary members are treated as if they are parts of the head company for income tax purposes.

2.25 Generally the mere act of consolidation is not expected to change the character of transactions involving assets dealt solely under the CGT provisions, where those assets continue to be held by a consolidated group in the same manner as held by a member of the group prior to consolidation. However, a consequence of the clean slate rules, currently being reviewed, in conjunction with the acquisition of assets by the head company can be to change the character of transactions involving some revenue assets (see paragraphs 2.35 to 2.41).

2.26 As is the situation under current law, it may be relevant to consider the nature of a transaction undertaken by a subsidiary member of a wholly-owned group in the context of the activities of the group as a whole, in order to determine the character of a particular act or transaction in an assessment of the consolidated group. The tax character of a transaction undertaken by a consolidated group will continue to be a question of fact to be determined in the light of all the circumstances.

2.27 It is possible for assets of the same type to be held for dual purposes within one wholly-owned group. For example, at any point in time one piece of land may be held as trading stock (e.g. for the purposes of land development) while another may be held as a capital asset (e.g. for the purposes of housing business premises) by a group. If that wholly-owned group chooses to consolidate, the current law will apply using existing principles and case law. In effect, transactions under consolidation are subject to the same scrutiny for the purposes of characterisation as those involving a single taxpayer.

## Concepts supporting the single entity rule

### *Cost setting rules – entry*

2.28 The assets of subsidiary members, deemed during consolidation to be assets of the head company, are also deemed to have a new acquisition date, being the joining time, and a new cost. The new cost is set under rules that treat the head company's cost of acquiring the entity as its cost of acquiring the entity's assets, including its businesses. This cost is worked out and allocated to the individual assets according to rules explained in Chapter 4. [*Schedule 1, item 1, section 701-15; Subdivision 705A*]

2.29 There are generally no tax consequences for an entity as a result of joining a consolidated group. Exceptions to this general rule are discussed in detail in paragraphs 4.28 to 4.30. Broadly, on joining a group, for the purposes of working out the subsidiary's income tax liability or tax loss for the period up to joining time, the subsidiary is taken to have disposed of each item of trading stock it brings into the group for an amount equal to:

- its value under section 70-40 of the ITAA 1997 if the item was on hand at the beginning of the income year; or
- the amount, if any, of the outgoing incurred in acquiring the item.

*[Schedule 1, item 1, section 701-20]*

2.30 The subsidiary will be entitled to a deduction for the decline in value of its depreciating assets in the period up to the joining time under the capital allowances provisions that are already in the income tax law.

***Cost setting rules – exit***

2.31 For the purposes covered by the single entity rule when an entity leaves a group, the head company is taken to have acquired the membership interests of the leaving entity for a cost equal to the head company's net cost for the assets the leaving entity takes with it. Where a number of related entities leave the group, at the one time, the same principle applies to the membership interests held by one in any of the entities *[Schedule 1, item 1, section 701-25]*. This preserves the alignment between the cost for membership interests in the entity and its assets. How to work out the net cost for the assets is explained in Chapter 4.

2.32 Liabilities owed by an entity leaving a consolidated group to members of the group at the leaving time are taken to have been purchased by the head company at that time for a payment equal to the market value of the liability. *[Schedule 1, item 1, section 701-30]*

2.33 When an entity leaves a consolidated group, the head company is taken to dispose of each item of trading stock the leaving entity takes with it from the group for an amount equal to:

- its value under section 70-40 of the ITAA 1997 if the item was on hand at the beginning of the income year; or
- the amount, if any, of the outgoing incurred in acquiring it.

*[Schedule 1, item 1, section 701-35]*

2.34 When an entity leaves a consolidated group, it is taken to have acquired the assets it takes from the group for a payment for each asset *[Schedule 1, item 1, section 701-40]*. Details of the amounts for these payments are provided in paragraphs 4.190 and 4.191.

***Clean slate rules***

2.35 As discussed, subsidiary members lose their individual income tax identity on consolidation. Also, the head company is taken to have acquired the assets and businesses of the subsidiary members, when they join a consolidated group. A corollary of these rules is that subsidiary members' individual income tax histories are *not* taken into account for the purposes of working out the income tax liability or losses:

- of the group, for any income year during which the subsidiary is a member; or

- of the entity, for any income year after it leaves the group.

2.36 The clean slate rules apply for the core purposes only, and do not, for example, affect an entity's responsibility for taxation liabilities relating to pre-consolidation periods. [*Schedule 1, item 1, sections 701-1, 701-5, 701-10 and 701-45*]

#### *Entry clean slate rule*

2.37 Subject to certain exceptions (discussed in paragraphs 2.42 and 2.43), an entity does not bring its income tax history into a group for the purposes of calculating the income tax liability or losses of the head company. The cost setting rules treat the acquisition of an entity by a consolidated group as the acquisition of the business of that entity. The entry clean slate rule will make it clear that amounts are not included in the assessable income nor deductions allowed to the head company for events that relate purely to the subsidiary before it joined the group. [*Schedule 1, item 1, section 701-5*]

2.38 Through the cost setting rules the head company is allocated a cost for the assets of a subsidiary based on its cost for membership interests in the subsidiary. Appropriate tax deductions will be allowed over time for all of these costs, whether through capital allowances, the cost of trading stock, the cost base of capital assets, or on the deemed cost of equity where it is re-created when an entity leaves a consolidated group. It is therefore necessary, for example, that the head company is not allowed a deduction purely because of something the subsidiary did before it became a member (e.g. incurring borrowing expenses), in addition to its entitlements based on the cost of acquiring the subsidiary. Without this rule, the head company would be allowed a deduction for an outgoing it did not incur.

2.39 Similar to when the assets of a business are acquired directly, the character of certain revenue assets and transactions occurring post-consolidation will change. Some consequences would be:

- to deny a deduction to the head company for bad debts written-off in respect of trade debts of the joining entity acquired by the head company at the joining time – (a capital loss will be allowed in respect of the write-off); and
- to deny a deduction to the head company for repairs to remedy defects that existed at the joining time – (the cost of repairs will be included in the cost base of the asset).

#### *Exit clean slate rule*

2.40 It is also necessary, for example, that deductions are not allowed to a leaving entity on the basis of things that happened to it (or any other entity) before it joined the group or while it was a member of the group. The assets and liabilities of an entity that leaves a consolidated group can

be very different from its assets and liabilities when it entered the group or when it was created by the group. For this reason, a leaving entity is treated as a completely new entity for income tax purposes. The exit clean slate rule ensures that nothing that happened to an exited entity before it joined or while it was a member of a consolidated group can be taken into account in working out the entity's post-consolidation income tax liability or losses for an income year after the entity ceased to be a subsidiary member. There will also be consequences concerning the character of transactions involving certain revenue assets and transactions occurring after the leaving time similar to the examples in paragraph 2.39.

*[Schedule 1, item 1, section 701-10]*

2.41 The clean slate rules are being reviewed to see whether the correct outcomes will be achieved under the income tax law in conjunction with the underlying principles behind consolidation. Consultation will occur in this regard.

#### *Clean slate exceptions*

2.42 The acquisition by the head company of a pre-CGT asset of a subsidiary member will not cause that asset to cease being a pre-CGT asset. Likewise, the acquisition by the leaving entity of a pre-CGT asset of the head company will not cause that asset to cease being a pre-CGT asset. This maintains the current law's treatment of pre-CGT asset transfers within wholly-owned groups. However, any acquisition of membership interests in the entity would still cause pre-CGT status in the asset to be lost if it resulted in the ultimate owners not continuing to hold majority underlying interest in the asset. *[Schedule 1, item 1, section 701-55]*

2.43 In addition, the head company will be entitled to accelerated depreciation in respect of a depreciating asset acquired when a subsidiary member joins a consolidated group where:

- the head company's deemed cost of acquiring a depreciating asset when a subsidiary member joins a consolidated group is not more than the subsidiary member's terminating value (see paragraph 4.41) for that asset; and
- the subsidiary member was entitled to accelerated depreciation, then the head company will also be entitled to accelerated depreciation in respect of that asset.

The head company can choose to reduce the payment amount for the depreciating asset to the subsidiary's terminating value for that asset (see paragraphs 4.52 and 4.53). *[Schedule 1, item 1, section 701-60]*

#### *Other exceptions to core rules*

2.44 The operation of the core rules is subject to any contrary provisions in Part 3-90 *[Schedule 1, item 1, section 701-65]*. For example, contrary to the clean slate entry rule, the rules covering the treatment of



losses and consolidated groups take into account things that happened to an entity before it joined a consolidated group. These rules are discussed in Chapters 5 to 8.

### *Anti-avoidance*

2.45 Consideration is being given to whether modifications to any core rules are necessary to ensure the appropriate application of anti-avoidance provisions in the income tax law.

### *Income year*

2.46 When a subsidiary entity joins a consolidated group part way through the income year, it ceases to be a taxpayer in its own right because of the operation of the single entity rule during consolidation. Therefore, its income tax return for the whole year will cover only things referable to the part of the year before its joining time. Similarly, when an entity leaves a group its return for the year will cover only things referable to the part of the year after its leaving time.

### *Entities that enter and leave a consolidated group in the same income year*

2.47 When a subsidiary entity joins and leaves a consolidated group during the same income year, special rules operate to ensure that pre- and post-consolidation calculations are undertaken separately, and that there is no netting off between the 2 or more parts of the same income year in which the entity is outside a group (of course, it has no taxable income during its period/s of membership of a consolidated group). It does not matter in which order the joining and leaving takes place, and the special rules apply to an entity that joins and leaves the same or different consolidated groups during the income year. This treatment reflects the fact that an entity loses its individual income tax identity upon joining a consolidated group, and acquires a fresh one upon exit. [*Schedule 1, item 1, section 701-45*]

2.48 Notional figures are worked out for the entity's taxable income, income tax payable on that taxable income and any losses for each part of the income year in which the entity is outside a group. These figures are worked out as if the start and end of that part were the start and end of the income year, ignoring things that happened in the other period/s. [*Schedule 1, item 1, subsections 701-45(3) and (4)*]

2.49 The entity's taxable income for the whole income year is worked out in order to link with provisions of the income tax law that assume an entity has one taxable income for an income year. The entity's income tax liability for the financial year is worked out by adding the notional income tax liability figures calculated for each part rather than by reference to the entity's taxable income for the whole year. [*Schedule 1, item 1, subsections 701-45(5) and (6)*]

2.50 The entity can have a loss for the income year only if it has a loss in the part of the income year ending at the end of the income year. This is because when an entity joins a consolidated group either its losses are transferred into the group in accordance with the loss transfer rules (described in Chapters 5 to 8) or they are cancelled and cannot be used by any entity. Because notional income tax liability is worked out separately for each part of the income year in which the entity is a taxpayer in its own right, losses in a later part of the income year cannot be used to offset income in an earlier part. [*Schedule 1, item 1, subsection 701-45(8)*]

2.51 Similarly, the only choices (e.g. choices of method of depreciation for items of plant) made by the entity in any part of such a year that have ongoing effect are those made in relation to the part that ends at the end of the income year. [*Schedule 1, item 1, subsection 701-45(9)*]

2.52 The special rules apply also to partnerships and trusts, which have net income rather than taxable income. [*Schedule 1, item 1, section 701-50*]

### **Example 1.1**

In one income year, an entity is a single taxpayer, then joins a consolidated group part way through the year and subsequently leaves the group without immediately joining another group. During that income year, there are 2 parts of the year in which the entity is a taxpayer in its own right.

For example, in the first part of the year, the entity has tax payable of \$10,000, worked out by reference to its notional taxable income for that part.

While the entity is a member of a consolidated group it is not a taxpayer but part of the head company, and so does not have any taxable income, income tax liability or losses in respect of that part of the income year.

The entity has a loss of \$5,000 for the part of the income year after it left the consolidated group. Nil tax is payable in respect of this part.

The total amount of tax payable by the entity for the whole of the financial year is:

$$\$10,000 + \text{nil} = \$10,000$$

The entity has a loss of \$5,000 for the income year.

## **Application and transitional provisions**

2.53 In general, these amendments will have effect from 1 July 2002.

2.54 A head company may elect on formation of a consolidated group to adopt the transitional option of using a joining entity's 'terminating value' as its cost of acquiring the assets from its members (the eligibility conditions for this election are explained in Chapter 4). In that case, the head company is deemed to acquire all the rights and obligations of the subsidiary resulting from things that happened to it before it became a member of the group. That is, the entry clean slate rule will not apply when this transitional option is chosen by the head company.

## **Consequential amendments**

2.55 There are various consequential amendments to the ITAA 1997 in relation to the measures discussed in this chapter. These amendments are related to the rules for working out an entity's income tax liability or losses if the entity becomes and ceases to be a member of a consolidated group in a single income year (sections 701-45 and 701-50). [*Schedule 1, Part 2, items 2 and 3*]



---

# Chapter 3

## Membership rules

---

### Outline of chapter

3.1 This chapter explains the rules dealing with the formation of a consolidated group, including rules dealing with the types of entities eligible to join such a group. It also explains the proposed notification requirements that will apply when there are changes in membership of a consolidated group.

### Context of reform

3.2 Consistent with Recommendation 15.1(i) of *A Tax System Redesigned*, certain groups of wholly-owned entities will be provided with a choice to be taxed as a single consolidated entity.

3.3 In order to give practical meaning to the concept of a single Australian taxpayer, entry into the consolidation regime is generally restricted to those groups who have a resident holding company at the head of the group. This means, for example, that wholly-owned groups in Australia that do not have a common Australian holding company between the non-resident parent and the Australian resident subsidiaries are unable to form a consolidated group under the ordinary membership rules. However, such groups may be eligible to form a MEC group. Rules relating to the formation and income tax treatment of MEC groups are discussed in Chapter 10.

3.4 Although consolidation is optional, if a group consolidates, all of the holding company's eligible resident wholly-owned subsidiaries, (whether companies, partnerships or trusts) must be included in the consolidated group. This rule is referred to as the 'all in' principle and will also apply to entities acquired in the future.

3.5 The 'all in' principle allows intra-group transactions to be ignored for tax purposes. Consolidation therefore offers major advantages to entity groups in terms of both reduced complexity and flexibility in commercial operations. Departure from the 'all in' principle would add considerable complexity to the consolidation regime and could compromise the integrity of the regime by allowing unintended tax benefits to be obtained from transactions between member and non-member entities.

3.6 In determining whether an entity is a wholly-owned subsidiary, in some cases employee shares are to be disregarded. This gives effect to

Recommendation 15.2(a)(i) of *A Tax System Redesigned*. Debt interests are also to be ignored. This is broadly in line with the proposal in *A Tax System Redesigned*, which proposed that the concept of ‘finance shares’ be used to identify debt. The broad term ‘finance shares’ has now been superseded by the debt/equity rules in Division 974 of the ITAA 1997 as a basis for identifying debt interests.

3.7 The inclusion of discretionary trusts and hybrid trusts in consolidated groups on the basis of a wholly-owned test departs from the recommendation in *A Tax System Redesigned*. The new test avoids introducing unnecessary complexity into the regime.

3.8 Certain entities are prevented from being a member of a consolidated group. Broadly, the provisions limiting the types of entities that can be a member of a consolidated group are designed to ensure that consolidated groups receive a tax treatment like ordinary Australian resident companies and that concessional tax treatment is neither effectively gained by nor denied to entities by becoming a member of a consolidated group.

## Summary of new law

3.9 The following summarises the key requirements for formation and membership of a consolidated group.

*What is a consolidated group?*

A consolidated group consists of:

- a head company; and
- all of the subsidiary members of the group (if any).

In general, before a consolidated group can be brought into being there must be:

- a consolidatable group in existence; and
- an effective choice made by the head company of that group to consolidate the group.

*What is a consolidatable group?*

A consolidatable group is a group of entities that is eligible to be consolidated.

A consolidatable group consists of:

- a head company; and
- all of the subsidiary members of the group,

provided there is, in addition to the head company, at least one subsidiary member.

<i>What is a head company?</i>	A head company is broadly an ordinary Australian resident company that is not a subsidiary member of a consolidatable or consolidated group.
<i>What is a subsidiary member of a consolidatable or consolidated group?</i>	<p>Broadly, an entity is eligible to be a subsidiary member of a consolidatable or consolidated group if:</p> <ul style="list-style-type: none"> <li>• it is a resident company, trust or partnership;</li> <li>• it is a wholly-owned subsidiary of the head company;</li> <li>• it would not/does not effectively gain or lose concessional tax treatment by being a subsidiary member of a consolidated group; and</li> <li>• any entities interposed between itself and the head company of the group are subsidiary members of the group, nominees or certain non-resident entities.</li> </ul>
<i>What entities are excluded from being a member of a consolidated group?</i>	Certain entities (such as companies subject to the mutuality principle and some cooperative companies) that receive different tax treatment, including concessional tax treatment, compared to ordinary Australian resident companies cannot be a member of a consolidated group. In addition, certain entities that would effectively gain concessional treatment by being a subsidiary member of a consolidated group headed by an ordinary Australian resident company cannot be subsidiary members.
<i>Can the head company revoke the choice to consolidate?</i>	No.
<i>What happens when an entity is no longer eligible to be a head company?</i>	In most cases any choice to consolidate by the entity will cease to have effect. Therefore, any consolidated group headed by the entity will cease to exist.
<i>What happens when a consolidated group no longer has subsidiary members?</i>	The consolidated group will continue to exist even though there are no subsidiary members of the group.

## Comparison of key features of new law and current law

<i>New law</i>	<i>Current law</i>
Consolidation is available to certain groups of wholly-owned entities that may comprise companies, partnerships	The rules for consolidation are intended to replace the current grouping provisions. Currently

<i>New law</i>	<i>Current law</i>
<p>and trusts. Consolidation provisions used to work out whether an entity is a wholly-owned subsidiary of the head company are based on, but are more flexible than, the current definition of 100% subsidiary. This definition is relevant to determining whether an entity is a member of a wholly-owned group.</p>	<p>grouping concessions may only be accessed by companies that are members of the same wholly-owned group.</p>

## Detailed explanation of new law

### What is a consolidated group?

3.10 A consolidated group is brought into existence by a choice to treat a consolidatable group of entities (see paragraphs 3.22 to 3.25) as a consolidated group. The company that was the head company of the consolidatable group on the day from which the choice will take effect is responsible for making the choice. [*Schedule 1, item 1, paragraph 703-5(1)(a)*]

3.11 When a consolidatable group becomes a consolidated group, *all* of the members of the *consolidatable* group will become members of the *consolidated* group. [*Schedule 1, item 1, subsection 703-5(3)*]

3.12 The *members* of a consolidatable group are:

- the head company; and
- all of the *subsidiary members* of the group.

[*Schedule 1, item 1, subsection 703-15(2)*]

3.13 The cessation of a MEC group can also bring a consolidated group into existence. This will occur if the cessation of a MEC group happens because the entity that is the sole eligible tier-1 company in the MEC group fails to satisfy the conditions for being an eligible tier-1 company and immediately after this time that entity meets the conditions for being a head company of a consolidated group [*Schedule 1, item 1, paragraph 703-5(1)(b) and subsection 703-55(1)*]. Chapter 10 explains the terms MEC group and eligible tier-1 company.

3.14 When a MEC group converts to a consolidated group, all of the entities that were members of the MEC group immediately before it ceased to exist will become members of the consolidated group. In particular, the company that was the sole eligible tier-1 company of the MEC group will become the head company of the consolidated group and every entity (if any) that was a subsidiary member of the MEC group will



---

become a subsidiary member of the consolidated group. [*Schedule 1, item 1, subsection 703-55(2)*]

3.15 At any point in time while the consolidated group is in existence, the members of the group will consist of all of the subsidiary members of the consolidated group (if any) together with the head company. [*Schedule 1, item 1, subsection 703-15(2)*]

3.16 An important effect of these rules is that a subsidiary member does not have an option *not* to be part of a consolidated group if a choice outlined in paragraph 3.10 has been made or where the consolidated group has been brought into existence by the cessation of a MEC group.

3.17 Further, a change in the composition of a *consolidated group* will *generally* not affect its existence, so long as the same head company exists [*Schedule 1, item 1, paragraph 703-5(2)(a)*]. This means, for example, that if, after a consolidated group comes into existence, there are no subsidiary members of the group and the only member of the group is the head company, the *consolidated group* will remain in existence. Such a group will consist only of the head company. [*Schedule 1, item 1, subsection 703-5(3)*]

3.18 However, where the head company no longer satisfies the prerequisites for being a head company, the *consolidated group* will cease to exist [*Schedule 1, item 1, paragraph 703-5(2)(a)*]. An example of where this could occur is where the head company becomes a subsidiary member of a consolidatable or consolidated group.

3.19 An exception to the general rule is being developed that will broadly ensure that a consolidated group will continue to exist where a company that is eligible to be a head company is interposed between the head company of a consolidated group and its shareholders. The exception will only apply in limited circumstances. For example, where the interposition is within the scope of Subdivision 124-G of the ITAA 1997.

3.20 A consolidated group will also cease to exist if the head company of the group becomes eligible to be a member of a MEC group. This could occur where:

- the head company of the consolidated group becomes a member of a MEC group; or
- the head company of the consolidated group becomes a member of a potential MEC group that consists of 2 or more eligible tier-1 companies of the same top company. [*Schedule 1, item 1, paragraph 703-5(2)(b)*]

The terms potential MEC group and top company are discussed in Chapter 10.

3.21 The key concept underlying the formation of a consolidated group is in most cases the existence of a consolidatable group. This concept will now be discussed, along with the categories of entities that are members of a consolidatable group.

## Consolidatable groups and their members

3.22 Consolidatable group is the label used to describe a type of group that is eligible to be consolidated.

3.23 A *consolidatable group* consists of:

- a head company; and
- all of the subsidiary members of the group.

*[Schedule 1, item 1, subsection 703-10(1)]*

3.24 As was discussed in paragraph 3.12, an entity that is either a head company or a subsidiary member of a consolidatable group will be a member of that group. *[Schedule 1, item 1, subsection 703-15(2)]*

3.25 A consolidatable group will only exist if there exists a head company and at least one subsidiary member *[Schedule 1, item 1, subsection 703-10(2)]*. Generally a head company existing alone without any subsidiary members is not eligible to consolidate. This is notwithstanding that a *consolidated group* can continue to exist even if the group loses all of its subsidiary members after formation and subsequently consists of the head company alone.

## What is a head company?

3.26 A *head company* is an entity that:

- is a company;
- has an income tax rate that is or equals the general company tax rate applied to some or all of its taxable income (if any);
- is not a type of entity that is excluded from membership of a consolidatable or consolidated group;
- is an Australian resident but not a prescribed dual resident;  
and
- is not a subsidiary member of a consolidatable or consolidated group.

*[Schedule 1, item 1, subsection 703-15(3), item 1 in the table]*

3.27 Note that the definition of head company contained in Division 166 and section 995-1 of the ITAA 1997 will be consequentially amended.

3.28 The first 3 dot points in paragraph 3.26 are collectively referred to as the 'income tax treatment requirements'. The fourth requirement is

---

referred to as the ‘Australian residence requirement’, while the fifth requirement is known as the ‘ownership requirement’. [*Schedule 1, item 1, subsection 703-15(3)*]

### ***Income tax treatment requirements***

3.29 The income tax treatment requirements are central in ensuring that consolidated groups receive a tax treatment like ordinary companies. Subsidiary members of a consolidated group will be treated as part of the head company rather than as separate entities under the rule providing for single entity treatment for consolidated groups. This means that the tax treatment that is effectively received by subsidiary members of a consolidated group will be determined by the tax treatment that is received by the head company of the group.

#### ***Requirement 1: The entity must be a company***

3.30 To qualify as a head company, an entity must be a company as defined in section 995-1 of the ITAA 1997.

3.31 A corporate limited partnership will also satisfy this requirement. This is consistent with the objective of ensuring consolidated groups receive a tax treatment like ordinary companies because these partnerships are effectively treated as companies for income tax purposes.

3.32 In relation to corporate unit trusts and public trading trusts, these entities cannot be head companies because the tax treatment of these entities is not identical to that of ordinary resident companies. For example, the trust loss measures contained in Schedule 2F of the ITAA 1936 apply to these entities.

3.33 In the December 2000 exposure draft, entities that were covered by the then proposed non-fixed trust rules were eligible to be a head entity (now head company). This is no longer the case. The previous approach reflected the proposal to afford these entities the same tax treatment as companies.

#### ***Requirement 2: The entity must have the general company tax rate (or an equivalent rate) applied to some or all of its taxable income***

3.34 This requirement effectively excludes companies from being eligible to be a head company of a consolidatable or consolidated group if they receive concessional tax treatment. This is achieved by requiring some or all of the taxable income of a company to be taxed at a rate that is or equals the general corporate tax rate.

3.35 If concessionally taxed companies were able to be a head company of a consolidated group, the concessions that these companies receive may be made available to all entities in the group through the single entity rule. The exclusion is designed to prevent this. Otherwise, consolidation may unintentionally extend these concessions to entities that are not otherwise entitled to them.

3.36 Some companies that have a rate of tax less than the company tax rate applying to some of their taxable income will satisfy requirement 2. These companies will not be excluded from being a member, including a head company, of a consolidatable group because those concessional rates often apply only to special types of income that are peculiar to those companies (e.g. life insurance companies). Existing rules that quarantine special classes of income that are subject to concessional rates of tax will apply in the context of a consolidatable group.

*Requirement 3: The entity must not be of a type that is excluded from membership of a consolidatable or consolidated group*

3.37 Entities that are excluded from membership of a consolidatable or consolidated group are detailed in Table 3.1. These entities are prevented from being a member of a consolidatable or consolidated group because of the way their income is treated for income tax purposes [Schedule 1, item 1, subsection 703-20(1)]. Requirement 3 is therefore a further mechanism to exclude from a consolidated group entities that do not receive a tax treatment like ordinary companies, including entities that receive concessional treatment relative to ordinary Australian resident companies. As discussed in paragraphs 3.34 and 3.35, the application of this feature in the head company context ensures that the concessions available to such entities do not apply to other members of the consolidated group and that the group receives a tax treatment like an ordinary resident company.

**Table 3.1: Entities which cannot be members of a consolidatable or consolidated group**

<i>This entity...</i>	<i>is excluded under...</i>	<i>because...</i>
An entity to which Division 50 of the ITAA 1997 applies.	Subsection 703-20(2), item 1 in the table.	The total ordinary and statutory income of these companies is exempt from income tax.
A recognised medium credit union (as defined under section 6H of the ITAA 1936).	Subsection 703-20(2), item 2 in the table.	These credit unions have a threshold placed on the tax payable on their taxable income, even though they are subject to the corporate tax rate.
An approved credit union (as defined under section 23G of the ITAA 1936) that is not a recognised medium credit union or a recognised large credit union (as defined under section 6H of the ITAA 1936).	Subsection 703-20(2), item 3 in the table.	These credit unions are entitled to an exemption under section 23G of the ITAA 1936 for interest received from non-corporate members.

<i>This entity...</i>	<i>is excluded under...</i>	<i>because...</i>
A non-profit company that is not a registered organisation (as those terms are defined in the ITRA 1986).	Subsection 703-20(2), item 4 in the table.	These companies have the corporate tax rate phased-in on their taxable income.
A company that is subject to the mutuality principle (see paragraphs 3.38 and 3.39).	Subsection 703-20(2), item 5 in the table.	Companies to which the mutuality principle applies do not derive assessable income from their members. Therefore, any amount received from a member of the entity that would otherwise be assessable income of a subsidiary member of a consolidated group headed by the entity would be effectively ignored.
Certain cooperative companies (as defined under section 117 of the ITAA 1936).	Subsection 703-20(2), item 6 in the table.	These companies would be allowed a special deduction under paragraph 120(1)(c) of the ITAA 1936 if at the time they applied an amount of their assessable income as described under that paragraph.
An entity that is a PDF (as defined under section 995-1 of the ITAA 1997) at the end of the income year (see paragraph 3.40).	Subsection 703-20(2), item 7 in the table.	These entities are subject to a concessional rate of tax compared to the general company tax rate.
A company that is a film licensed investment company at the time (as defined in section 375-855 of the ITAA 1997).	Subsection 703-20(2), item 8 in the table.	Tax losses or net capital losses cannot be transferred to or from these companies. Further, section 375-880 of the ITAA 1997 prevents these companies from claiming deductions for expenditure on a film where the amount spent is an amount of Film Licensed Investment Company concessional capital.

<i>This entity...</i>	<i>is excluded under...</i>	<i>because...</i>
<p>A trust that is:</p> <ul style="list-style-type: none"> <li>• a complying superannuation entity;</li> <li>• a non-complying ADF; or</li> <li>• a non-complying superannuation fund,</li> </ul> <p>(as those terms are defined in section 267 of the ITAA 1936).</p>	<p>Subsection 703-20(2) item 9 in the table.</p>	<p>The taxable income of these entities is subject to tax at rates other than the general company tax rate.</p>

3.38 The following criteria are used to identify companies that are subject to the mutuality principle:

- the company is not carried on for the object of securing a profit or pecuniary gain for its members;
- the company does not have capital divided into membership interests held by its members; and
- the company does not hold property in which any of its members has a direct or indirect disposable interest, other than in the case of the company winding up.

*[Schedule 1, item 1, subsection 703-20(2), item 5 in the table]*

3.39 These criteria are intended to reflect the common law underlying the mutuality principle and are virtually identical to criteria used elsewhere in the income tax law to identify mutual entities.

3.40 A company that becomes a PDF during an income year and is still a PDF at the end of the income year will not be eligible to be a member, including a head company, of a consolidated or consolidatable group for the entire income year. *[Schedule 1, item 1, subsection 703-20(2), item 7 in the table]*

### ***Australian residence requirements***

3.41 Only companies that are Australian residents can be a head company of a consolidatable or consolidated group. This reflects the position that consolidated group treatment is generally only available to Australian resident entities.

3.42 Companies that are prescribed dual residents are ineligible to be a head company of a consolidatable or consolidated group on the basis that prescribed dual residents do not receive the same tax treatment as ordinary resident companies. In particular, wholly-owned groups headed by prescribed dual residents are currently unable to access the grouping concessions that are being replaced by the consolidation measures.

### ***Ownership requirements***

3.43 A head company must not be a subsidiary member of a consolidatable or consolidated group. This requirement reflects the general principle that a company can only be either a head company or a subsidiary member of a consolidatable group (whether or not the group is consolidated), *but it cannot be both*.

3.44 Without this rule, a company could potentially be a member of more than one consolidated group. For example, a company could be a head company of one consolidated group while being a subsidiary member of another consolidated group. This is unworkable, as the activities of the company cannot be appropriately attributed to one group in preference to the other.

3.45 It is possible for an entity to be neither a head company nor a subsidiary member of a consolidatable or consolidated group. This could occur for a number of reasons. An example is where the entity is of a type that is specifically precluded from membership of a consolidatable or consolidated group (see paragraph 3.37).

3.46 It is also possible for an entity to be a head company of a consolidatable group or consolidated group whilst being a *wholly-owned subsidiary* of another entity (see paragraphs 3.61 to 3.76 for a discussion on wholly-owned subsidiaries) provided that the head company is not a *subsidiary member* of a consolidatable or consolidated group.

### **What is a subsidiary member of a consolidatable or consolidated group?**

3.47 An entity is eligible to be a subsidiary member of a consolidatable group or consolidated group if:

- the entity is a company, trust or partnership;
- in the absence of single entity treatment, some or all of its taxable income would be taxed at a rate that is or equals the general company tax rate (applies only if the entity is a company);
- it is not an entity that is precluded from membership of a consolidatable or consolidated group;
- the entity passes an Australian residence test;
- the entity is a wholly-owned subsidiary of the head company; and
- any entities that are interposed between the head company and itself are subsidiary members (of the group), nominees or certain non-resident entities.

*[Schedule 1, item 1, subsection 703-15(3), item 2 in the table]*

3.48 The first 3 requirements are collectively known as the ‘income tax treatment requirements’. The fourth requirement is referred to as the ‘Australian residence requirement’, and together the fifth and sixth requirements are known as the ‘ownership requirements’. [*Schedule 1, item 1, subsection 703-15(3)*]

3.49 Working out whether an entity is a subsidiary member of a consolidatable or consolidated group is important for 2 reasons:

- to determine who the members (if any) of a consolidated or consolidatable group are; and
- an entity that is a subsidiary member of a consolidatable or consolidated group cannot itself be a head company of a consolidated or a consolidatable group.

### ***Income tax treatment requirements***

3.50 The income tax treatment requirements have been discussed in paragraphs 3.29 to 3.40 (although the discussion did not extend to trusts or partnerships). The earlier discussion focused on the need for a head company to meet these requirements. In this context, requiring a head company to satisfy these conditions ensures consolidated groups receive a tax treatment like ordinary companies. It also ensures that the concessions received by particular entities are not effectively received by all of the subsidiary members of a consolidated group headed by such an entity.

3.51 The reason for limiting the membership requirements in relation to subsidiary members is slightly different. These conditions are directed at preserving an entity’s concessional tax treatment. More specifically, the conditions ensure that an entity does not effectively lose relative concessional treatment by being a subsidiary member of a consolidated group headed by a company that does not receive relative concessional treatment. For example, due to the operation of the single entity rule, the income of an entity to which Division 50 of the ITAA 1997 applies would no longer be exempt from income tax if the entity were permitted to be a subsidiary member of a consolidated group headed by an ordinary Australian resident company. It is important to prevent these entities and other concessional tax entities from being subsidiary members because, as mentioned in paragraph 3.16, a subsidiary member does not have an option not to be part of a consolidated group if a choice outlined in paragraph 3.10 has been made or where the consolidated group has been brought into existence by the cessation of a MEC group.

3.52 The limitations also act as an integrity measure to prevent certain entities from effectively gaining relative concessional treatment by being a subsidiary member of a consolidated group headed by a company that does receive relative concessional treatment. For example, the income of a non-complying superannuation fund would be concessional tax if it were permitted to be a subsidiary member of a consolidated group headed by a company that was taxed at the general company tax rate. This is



because the taxable income of a non-complying superannuation fund is taxed at a rate higher than the general company tax rate.

3.53 Companies in addition to trusts and partnerships may be eligible to be subsidiary members of a consolidatable or consolidated group. The inclusion of most trusts as subsidiary members of a consolidated group is appropriate on the basis that income generally maintains its character as it flows through the trust to the beneficiaries or objects. Likewise, most partnerships (other than corporate limited partnerships) are simply conduits through which amounts flow-through to the partners.

3.54 The inclusion of trusts and partnerships in a consolidated group is also important to ensure generally that companies that are currently members of the same wholly-owned group under section 975-500 of the ITAA 1997 can continue to access grouping benefits within the confines of a consolidated group. Certain trusts and partnerships, for example, may currently form part of the ownership structure of such wholly-owned groups.

***Australian resident requirements***

3.55 As discussed in paragraph 3.41, the requirement to pass a residency test reflects the general principle that consolidated group treatment is generally only available to Australian resident entities.

3.56 The Australian residence test that must be satisfied depends on the nature of the entity being tested.

*The test that applies to companies*

3.57 If the entity is a company (including a corporate limited partnership), it must be an Australian resident (but not a prescribed dual resident) [*Schedule 1, item 1, subsection 703-15(3), column 3 of item 2 in the table*]. The term Australian resident is defined in section 995-1 of the ITAA 1997.

*The tests that apply to trusts*

3.58 The type of test that needs to be satisfied depends on the type of trust being tested. The purpose of this approach is to avoid overlap with the other separate regimes that presently govern non-resident trusts. It also helps to ensure that the head company’s income is subject to income tax only where appropriate taxing rights exist.

3.59 The relevant tests are summarised in Table 3.2.

**Table 3.2: Australian residence requirements for trusts**

<i>Trust type</i>	<i>Tests to be satisfied</i>
A trust other than a unit trust.	The trust must be a resident trust estate for the income year for the purposes of Division 6 of Part III of the ITAA 1936.

A unit trust other than a corporate unit trust or a public trading trust.	<p>The trust must be:</p> <ul style="list-style-type: none"> <li>• a resident trust estate for the income year for the purposes of Division 6 of Part III of the ITAA 1936; and</li> <li>• a resident trust for CGT purposes for the income year.</li> </ul>
A corporate unit trust or a public trading trust.	The trust must be a resident unit trust (as defined in whichever one of sections 102H and 102Q of the ITAA 1936 is relevant) for the income year.

*[Schedule 1, item 1, section 703-25 and subsection 703-15(3), column 3 of item 2 in the table]*

### *Partnerships*

3.60 No residency test applies to partnerships (other than corporate limited partnerships) *[Schedule 1, item 1, subsection 703-15(3), column 3 of item 2 in the table]* because a partnership will be a resident partnership for most income tax purposes where at least one of the partners is a resident. In a consolidation context, this will mean that a partnership whose partners are subsidiary members (having satisfied the Australian residence requirements themselves) will be a resident partnership for most income tax purposes. It is therefore unnecessary to impose a further residency test on partnerships.

### *Ownership requirements*

#### *The entity is a wholly-owned subsidiary of the head company*

3.61 The rules for working out whether an entity is a wholly-owned subsidiary of the head company are based on the definition of 100% subsidiary in section 975-505 of the ITAA 1997. Among the differences between the rules for wholly-owned subsidiaries and the section 975-505 definition of 100% subsidiary are that:

- the rules for wholly-owned subsidiaries apply to companies, partnerships and trusts, whereas section 975-505 only applies to companies; and
- the rules for wholly-owned subsidiaries (specifically, special rules one and 2 outlined in paragraphs 3.68 to 3.76) will treat an entity as a wholly-owned subsidiary in circumstances that would otherwise prevent the entity from being a wholly-owned subsidiary. An example is where minor holdings of shares in a company have been issued under employee share acquisition arrangements. There are no such provisions in section 975-505.

The general test to determine whether an entity is a wholly-owned subsidiary of the head company

3.62 To be a wholly-owned subsidiary of the head company (the holding entity), all of the membership interests in the entity (the subsidiary entity) must be beneficially owned by:

- the holding entity;
- one or more wholly-owned subsidiaries of the holding entity; or
- a combination of the holding entity and one or more wholly-owned subsidiaries of the holding entity.

*[Schedule 1, item 1, subsection 703-30(1)]*

3.63 This rule is capable of multiple applications. This means that an entity can only be a wholly-owned subsidiary of the head company (the holding entity) if it is either a wholly-owned subsidiary of the holding entity or a wholly-owned subsidiary of a wholly-owned subsidiary of the holding entity. *[Schedule 1, item 1, subsection 703-30(2)]*

3.64 For the purposes of the general wholly-owned subsidiary test in paragraph 3.62, **membership interest** means each interest or set of interests or each right or set of rights in relation to an entity by virtue of which you are a member *[Schedule 1, item 4, section 960-135]*. An entity will be a member of another entity in circumstances set out in Table 3.3.

**Table 3.3: Entities and their members**

<i>Entity</i>	<i>Member</i>
A company.	A member of the company or a stockholder in the company.
A partnership.	A partner in the partnership.
A trust (except a corporate unit trust or a public trading trust).	A beneficiary, unit holder or object of the trust.
A corporate unit trust or a public trading trust.	A unit holder of the trust.

*[Schedule 1, item 4, subsection 960-130(1)]*

3.65 If 2 or more entities jointly hold interests or rights that give rise to membership of another entity, each of them is a member of the other entity. *[Schedule 1, item 4, subsection 960-130(2)]*

3.66 An entity is not a member of another entity just because it holds interests or rights in that other entity that are debt interests *[Schedule 1, item 4, subsection 960-130(3)]*. Thus, debt interests do not constitute membership interests. Such interests will therefore be disregarded when determining whether an entity is a wholly-owned subsidiary. The term

‘debt interest’ has the meaning given by Subdivision 974B of the ITAA 1997. It is appropriate that these shares are disregarded because they are not in the nature of equity and therefore should not be considered when contemplating the ownership structure of a group.

### Special rules

3.67 As mentioned in paragraph 3.61, an entity may be treated as if it were a wholly-owned subsidiary despite failing the general test in paragraph 3.62 if the conditions in the special rules are satisfied. These special rules are discussed in paragraphs 3.68 to 3.76.

#### Special rule 1: Treating entities as wholly-owned subsidiaries by disregarding employee shares

3.68 An entity will be taken to be a wholly-owned subsidiary of another entity, if it is not otherwise so only because certain shares acquired under an ESAS are:

- beneficially owned in it; or
- beneficially owned in a company that is interposed between it and another entity.

This is achieved by treating those shares as not existing. [*Schedule 1, item 1, subsections 703-35(2) and (3)*]

3.69 The purpose of this special rule is to ensure an entity can be part of a consolidatable group if it is only the presence of these shares that is preventing it from being part of that group. Without this rule, it is likely the benefits of being in a consolidated group will be denied to an entity whose equity is effectively wholly-owned by a head company of a consolidatable group. [*Schedule 1, item 1, subsection 703-35(1)*]

3.70 Shares issued under an ESAS arrangement will only be disregarded if:

- the percentage of ordinary shares owned by entities under the scheme does not exceed 1% of the number of ordinary shares in the company [*Schedule 1, item 1, subsection 703-35(4)*]; and
- the additional criteria outlined in paragraph 3.71 are met.

3.71 The additional criteria are as follows:

- the share must have been acquired:
  - by the entity in relation to the employment of the entity or services provided by the entity in accordance with subsections 139C(1) and (2) of the ITAA 1936; or

- as the result of the exercise of a *right* that the entity acquired in the circumstances set out in those subsections;
- all of the shares available for acquisition under the scheme must be ordinary shares or rights in respect of ordinary shares;
- at the time the share was acquired, the entity did not hold a legal or beneficial interest in more than 5% of the shares in the company, and was not in a position to cast or control the casting of more than 5% of the maximum number of votes at a general meeting, as required by subsections 139CD(6) and (7) of the ITAA 1936;
- the company is not covered by section 139DF of Division 13A of the ITAA 1936 because the business of the company is the acquisition, sale or holding of shares, securities or other investments, and the entity is employed by both that company and another company in the same company group; and
- at the time at which the share was acquired, an offer to acquire shares or rights in the company or in a holding company must have been available to 75% of the permanent employees of the employing company (the employer).

*[Schedule 1, item 1, subsection 703-35(5)]*

3.72 If all of the conditions in paragraph 3.71 are satisfied except the last mentioned condition, the share may still be disregarded if the Commissioner has made a determination under subsection 139CD(8) of the ITAA 1936 that this condition was taken to have been satisfied because the Commissioner considered that the employer had done everything reasonably practicable to ensure the condition was satisfied.

*[Schedule 1, item 1, subsection 703-35(6)]*

3.73 The criteria in paragraphs 3.71 and 3.72 are broadly based on the rules in Division 13A of Part III of the ITAA 1936, which provides generally for the taxation treatment of shares and rights acquired under employee share schemes. However, as implied by paragraphs 3.71 and 3.72, not all of the requirements of Division 13A must be met for a share to be disregarded. In particular, the shares or rights do not have to be issued at a discount (i.e. for a consideration less than the market value of the share or right).

#### Special rule 2: Treating entities held through non-fixed trusts as wholly-owned subsidiaries

3.74 An entity (the test entity) will nevertheless be treated as a wholly-owned subsidiary of another entity despite there being a trust that is not a fixed trust interposed between it and the head company of the group. This is achieved by treating the interposed trust as a fixed trust and all of its objects as beneficiaries. *[Schedule 1, item 1, subsection 703-40(2)]*

3.75 The purpose of this special rule is to ensure that an entity is not prevented from being a subsidiary member of a consolidatable or consolidated group just because there is a trust other than a fixed trust interposed between the test entity and the head company of the group. *[Schedule 1, item 1, subsection 703-40(1)]*

3.76 Due to the nature of the interposed trust, it may not be possible to beneficially own membership interests in the test entity. This means that, in the absence of special rule 2, it may not be possible for the test entity to be a wholly-owned subsidiary of the head company (and thus a subsidiary member of a consolidatable or consolidated group). This result would be an unnecessary compromise of the 'all in' principle.

*Any entities that are interposed between the head company and itself are subsidiary members (of the group), nominees or certain non-resident entities*

3.77 Any entities interposed between the entity being tested (the test entity) and the head company of a consolidatable or consolidated group must be either:

- a subsidiary member of the group; or
- an entity that holds membership interests in the test entity or a subsidiary member of the group (that is interposed between the head company and the test entity) only as a nominee of one or more entities that are members of the group.

*[Schedule 1, item 1, subsections 703-45(1) and (2)]*

3.78 In the absence of this requirement, an entity could be a subsidiary member of a consolidatable or consolidated group despite there being a non-member entity (other than a nominee) interposed between it and the head company that was ineligible to be a subsidiary member of the group.

3.79 If an entity (other than a nominee) within the ownership structure of a consolidated group is not a member of the consolidated group, the integrity of the consolidation regime (including the single entity rule) may be compromised by allowing unintended benefits to be obtained from transactions between member and non-member entities, unless special rules were developed to eliminate these unintended consequences.

3.80 On the other hand, it is desirable to allow interposed entities that are nominees of either the head company or a subsidiary member of the group to remain external to the group because this leads to the intended result of reflecting the substance underlying common membership interest holding arrangements and does not compromise the objects of single entity treatment.

3.81 In certain circumstances, the interposed entity requirements in paragraph 3.77 are relaxed to allow certain resident companies, trusts and

partnerships to be members of a consolidatable or consolidated group despite one or more non-member foreign resident entities being interposed between the resident entities and the head company of the group [*Schedule 1, item 1, subsection 703-45(1)*]. The rules in paragraph 3.77 are relaxed in order to relieve certain wholly-owned groups of the burden of restructuring. Supporting rules will be developed to ensure that there are no unintended consequences such as those alluded to in paragraph 3.79.

3.82 The test to establish whether an entity (the test entity) can be a subsidiary member of a consolidatable or consolidated group despite the existence of one or more interposed non-resident entities will be determined by the nature of the entity being tested. The relevant tests (referred to as the interposed foreign resident tests) are outlined in paragraphs 3.83 and 3.84 and illustrated in Example 3.6.

### Interposed Foreign Resident Tests

#### The test that applies where the test entity is a company

3.83 Where the test entity is a company, it will qualify as a subsidiary member of a consolidatable or consolidated group if:

- there is at least one entity interposed between the test entity and the head company of the group that is either:
  - a foreign resident company (referred to as a ‘non-resident company’); or
  - a trust that does not meet the residency requirements set out in Table 3.2 (referred to as a ‘non-resident trust’);
- each entity interposed between the test entity and the head company of the group is one of the following:
  - an entity that is a subsidiary member of the group;
  - a non-resident company;
  - a non-resident trust;
  - an entity that holds membership interests in an entity interposed between it and the test entity, or in the test entity, only as a nominee of one or more entities each of which is a member of the group, a non-resident trust or a non-resident company; or
  - a partnership, where each partner is a non-resident company or a non-resident trust; and

- the test entity would be a subsidiary member of the group if it was assumed that each of the following interposed entities was a subsidiary member of the group:
  - each interposed entity that is a non-resident company; and
  - each interposed entity that is a non-resident trust.

*[Schedule 1, item 1, subsection 703-45(3)]*

The test that applies where the test entity is a trust or partnership

3.84 If the test entity is a trust or partnership, it will be a subsidiary member of a consolidatable or consolidated group provided that it would be a subsidiary member of the group had the head company beneficially owned all of the membership interests beneficially owned by each company that qualifies as a subsidiary member because the test in paragraph 3.83 is satisfied. *[Schedule 1, item 1, subsection 703-45(4)]*

3.85 The interposed foreign resident tests effectively allow the interposed non-resident entities to be disregarded for the purposes of determining who is a subsidiary member of a consolidatable or consolidated group. However, the non-resident entities will not themselves become subsidiary members of the consolidatable or consolidated group.

### **Examples of the operation of the membership rules**

3.86 Examples 3.1 to 3.6 demonstrate the application of the membership rules in some different circumstances.

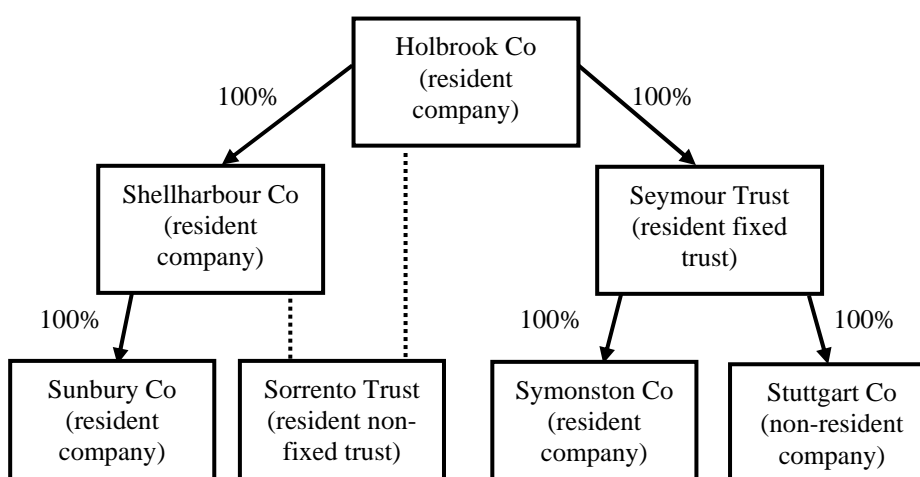

**Example 3.1**

Holbrook Co is an Australian resident company that beneficially owns 100% of the membership interests in Shellharbour Co, another Australian resident company, and is the only beneficiary of Seymour Trust, which is an Australian resident fixed trust (that complies with section 703-25).

In turn, Shellharbour Co beneficially owns 100% of the membership interests in Sunbury Co, an Australian resident company and is an object of Sorrento Trust, an Australian resident non-fixed trust (that complies with section 703-25), along with Holbrook Co.

Seymour Trust beneficially owns 100% of the membership interests in Symonston Co, an Australian resident company, and 100% of the membership interests in Stuttgart Co, which is a non-resident company.

**What entity or entities are eligible to be a head company?**

Only Holbrook Co is a head company in this example.

Applying subsection 703-15(3), item 1 in the table, Holbrook Co:

- meets the income tax treatment requirements because:
  - it is a company;
  - it has the general company tax rate applied to some or all of its taxable income; and
  - it is not a type of entity that is excluded from membership of a consolidatable or consolidated group (see section 703-20);
- meets the Australian residence requirements because it is an Australian resident and not a prescribed dual resident; and

- meets the ownership requirements because it is not a wholly-owned subsidiary of an entity that meets the income tax treatment and the Australian residence requirements.

Shellharbour Co, Sunbury Co and Symonston Co meet the income tax treatment and Australian residence tests (being ordinary Australian resident companies). However, they do not meet the ownership requirements as they are wholly-owned subsidiaries of another entity that meets the income tax treatment and Australian residence requirements – Holbrook Co.

Seymour Trust and Sorrento Trust do not satisfy the income tax treatment requirements because they are not companies. Also, they are wholly-owned subsidiaries of a holding entity, Holbrook Co, and thus fail the ownership requirements.

Being a non-resident company that is a wholly-owned subsidiary of a holding entity, Holbrook Co, Stuttgart Co fails the Australian residence and ownership requirements.

#### **What entity or entities are subsidiary members?**

Shellharbour Co, Seymour Trust, Sunbury Co, Sorrento Trust and Symonston Co are subsidiary members of a consolidatable group with Holbrook Co as the head company.

Shellharbour Co is a subsidiary member of the consolidatable group headed by Holbrook Co under subsection 703-15(3), item 2 in the table because Shellharbour Co:

- meets the income tax treatment requirements because:
  - it is a company;
  - it has some or all of its taxable income taxed at the general company rate; and
  - it is not an entity that is precluded from membership of a consolidatable or consolidated group (see section 703-20);
- meets the Australian residence requirements because it is an Australian resident and not a prescribed dual resident; and
- meets the ownership requirements because it is a wholly-owned subsidiary of Holbrook Co (because all of the membership interests in Shellharbour Co are beneficially owned by holding entity, Holbrook Co).

Seymour Trust is a subsidiary member of a consolidatable group headed by Holbrook Co under subsection 703-15(3), item 2 in the table. This is because Seymour Trust is an Australian resident trust (satisfying section 703-25) that is not covered by the list of entities that are specifically excluded from being a member of a consolidatable or consolidated group and it is a wholly-owned subsidiary of holding entity, Holbrook Co (all of its membership interests are beneficially owned by Holbrook Co). That is, Seymour Trust meets the income tax treatment, Australian residence and ownership tests.

Sunbury Co, Sorrento Trust and Symonston Co are also subsidiary members of a consolidatable group headed by Holbrook Co under subsection 703-15(3) item 2 in the table. Sunbury Co and Symonston Co are ordinary Australian resident companies and Sorrento Trust is a resident trust (that satisfies section 703-25). These entities therefore satisfy the income tax treatment and Australian residence requirements. Sunbury Co and Symonston Co meet the ownership requirements because all of their membership interests are beneficially owned by wholly-owned subsidiaries of Holbrook Co (Shellharbour Co in the case of Sunbury Co and Seymour Trust in the case of Symonston Co). Further, each entity that is interposed between either Sunbury Co or Symonston Co and holding entity Holbrook Co is a subsidiary member of Holbrook Co. Sorrento Trust satisfies the ownership requirements as together Holbrook Co and Shellharbour Co, a wholly-owned subsidiary of Holbrook Co, beneficially own all of its membership interests. Further, Shellharbour Co, which is interposed between Sorrento Trust and Holbrook Co, is a subsidiary member of Holbrook Co. Subsection 703-30(2) ensures that the previous applications of the wholly-owned subsidiary rule for Shellharbour Co and Seymour Trust (explained earlier in this example) also apply in testing Sunbury Co, Sorrento Trust and Symonston Co.

Stuttgart Co is not eligible to be a subsidiary member of a consolidatable group as it fails the Australian residence requirements – it is a non-resident company.

### **What consolidatable groups are there?**

There is one consolidatable group, whose members consists of Holbrook Co as the head company and Shellharbour Co, Seymour Trust, Sunbury Co, Sorrento Co and Symonston Co as subsidiary members. If Holbrook Co makes an effective choice to consolidate the group under section 703-50, this group will become a consolidated group under paragraph 703-5(1)(a).

### **Example 3.2**

Assume the same facts as Example 3.1, except Hotham Co, an Australian resident company, acquires 100% of the shares in Holbrook Co and becomes the beneficial owner of all of the membership interests in Holbrook Co. Assume also that the acquisition does not come within the scope of Subdivision 124G of the ITAA 1997. As indicated in paragraph 3.19, rules dealing with the outcome of such acquisitions are currently under development.

### **What consolidatable groups are there?**

Again there is only one consolidatable group, however now Hotham Co is the head company.

Holbrook Co loses its status as a head company because it has become a wholly-owned subsidiary of another entity that meets the income tax and residency requirements (Hotham Co) – see subsection 703-15(3), column 4 of item 1 in the table. Therefore, under subsection 703-15(3), item 2 in the table, Holbrook Co becomes a subsidiary member of the consolidatable group headed by Hotham Co. If Holbrook Co had chosen to consolidate the group in Example 3.1, that consolidated group would cease to exist – see paragraph 703-5(2)(a).

Under subsection 703-15(3), item 2 in the table, Shellharbour Co, Seymour Trust, Sunbury Co, Sorrento Trust and Symonston Co are all subsidiary members of a consolidatable group headed by Hotham Co.

Hotham Co must make a choice to consolidate this group before it becomes a consolidated group.

### Example 3.3

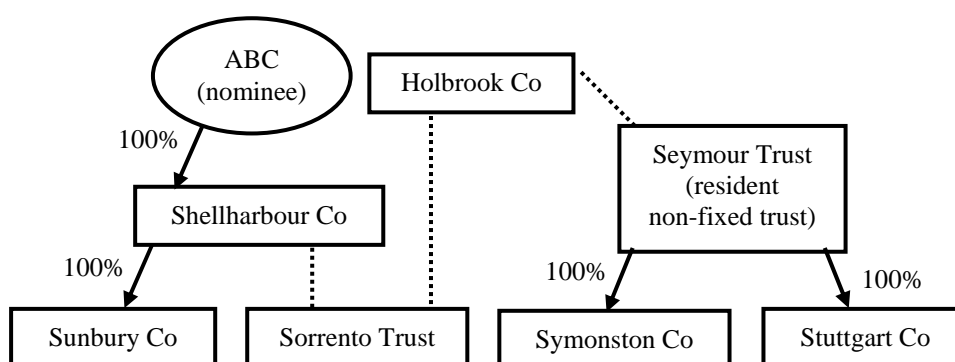

This example modifies Example 3.1, the differences being:

- ABC is a nominee of Holbrook Co and holds all of the shares in Shellharbour Co on behalf of Holbrook Co; and
- Seymour Trust is a non-fixed trust.

### What consolidatable groups are there?

There is only one consolidatable group consisting of Holbrook Co as head company and Shellharbour Co, Seymour Trust, Sunbury Co, Sorrento Trust and Symonston Co as subsidiary members.

Holbrook Co is a head company in this example for reasons cited in Example 3.1.

Applying subsection 703-15(3), item 2 in the table, Shellharbour Co meets the income tax treatment and Australian residence requirements as it is an ordinary Australian resident company. It meets the ownership requirements because it is a wholly-owned subsidiary of Holbrook Co (Holbrook Co *beneficially* owns all of

the membership interests in Shellharbour Co despite these shares being held by ABC). In this example, the exception in section 703-45 applies to ensure that Shellharbour Co is a subsidiary member of a consolidatable group headed by Holbrook Co despite there being a non-member entity interposed between Holbrook Co and Shellharbour Co, as the non-member entity is ABC which holds membership interests in Shellharbour Co as a nominee of head company, Holbrook Co. ABC is not a subsidiary member of the consolidatable group headed by Holbrook Co as it fails the ownership requirements (its membership interests are not beneficially owned by Holbrook Co and it is therefore not a wholly-owned subsidiary of Holbrook Co).

Seymour Trust, Sunbury Co and Sorrento Trust are subsidiary members of a consolidatable group headed by Holbrook for reasons discussed in Example 3.1. However, there is one difference flowing from the introduction of ABC – being the application of section 703-45. In this scenario, section 703-45 is satisfied because each entity interposed between either Sunbury Co or Sorrento Trust and Holbrook Co is either a subsidiary member of Holbrook Co (Shellharbour in this instance) or a nominee of head company, Holbrook Co (ABC).

Being an ordinary resident company, Symonston Co satisfies the income tax treatment and Australian residence tests in subsection 703-15(3), item 2 in the table. Under section 703-40, it is a wholly-owned subsidiary of Holbrook Co because it would have been a wholly-owned subsidiary of Holbrook Co had Seymour Trust been a fixed trust and Holbrook Co been a beneficiary (rather than an object). It therefore satisfies the ownership requirements in subsection 703-15(3), item 2 in the table.

As discussed in Example 3.1, Stuttgart Co cannot be a subsidiary member of a consolidatable group headed by Holbrook Co as it fails the Australian residence requirements (it is a non-resident company).

**Example 3.4**

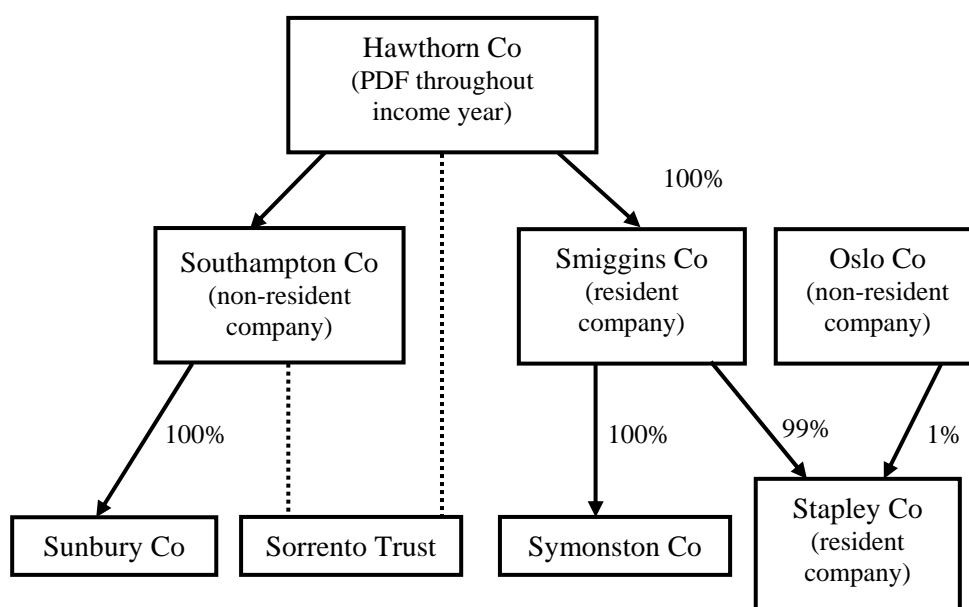

This is a modified version of Example 3.1. The differences are:

- Hawthorn Co is a PDF throughout the income year and replaces Holbrook Co;
- Southampton Co is a non-resident company and replaces Shellharbour Co;
- Smiggins Co is an Australian resident company and replaces Seymour Trust; and
- Stapley Co replaces Stuttgart Co and is an Australian resident company whose membership interests are 99% beneficially owned by Smiggins Co and Oslo Co, a non-resident company, beneficially owns the other 1% of the membership interests.

**What entity or entities are eligible to be a head company?**

Sunbury Co, Smiggins Co and Stapley Co are eligible to be head companies under subsection 703-15(3), item 1 in the table.

Both Sunbury Co and Smiggins Co meet the income tax treatment and Australian residence requirements, being ordinary Australian resident companies. They are both wholly-owned subsidiaries of another entity (Hawthorn Co in the case of Smiggins Co, and Southampton Co and Hawthorn Co in the case of Sunbury Co). However, they both satisfy the ownership tests because they are not wholly-owned subsidiaries of entities that meet the income tax treatment and Australian residence requirements (discussed later in this example).

Being an ordinary Australian resident company, Stapley Co satisfies the income tax treatment and Australian residence requirements. It meets the ownership requirements because it is not a wholly-owned subsidiary of another entity that meets the income tax treatment and Australian residence requirements.

Hawthorn Co, Southampton Co, Sorrento Trust and Symonston Co are not eligible to be head companies for the following reasons:

- Hawthorn Co fails the income tax treatment requirements because it is an entity that is specifically precluded from being a member of a consolidatable or consolidated group – see section 703-20;
- Southampton does not meet the Australian residence requirements because it is a non-resident company;
- Sorrento Trust does not meet the income tax treatment criterion because it is an entity other than a company; and
- Symonston Co is a wholly-owned subsidiary of an entity that meets the income tax treatment and Australian residence requirements (all of its membership interests are beneficially owned by Smiggins Co).

**What entity or entities are subsidiary members?**

Symonston Co qualifies as a subsidiary member of a consolidatable group headed by Smiggins Co under subsection 703-15(3), item 2 in the table. Being an ordinary Australian resident company Symonston Co satisfies the income tax treatment and Australian residence requirements. It meets the ownership requirements because it is a wholly-owned subsidiary of Smiggins Co.

**What consolidatable groups are there?**

There is only one consolidatable group consisting of Smiggins Co as the head company and Symonston Co as a subsidiary member.

For there to be a consolidatable group there must exist a head company and at least one subsidiary member – see subsection 703-10(2). Although Sunbury Co and Stapley Co meet the definition of head company, they are not head companies of a consolidatable group as neither Sunbury Co nor Stapley Co have any subsidiary members. If either of these entities were to become the beneficial owner of all of the membership interests in an entity eligible to be a subsidiary member, a consolidatable group would be formed at that time.

**What if the interests owned by Oslo were debt interests?**

The interests owned by Oslo would be disregarded for the purposes of working out whether Stapley Co was a wholly-owned subsidiary of another entity because these interest do not constitute membership interests as defined in section 960-135. With these interests disregarded, Stapley Co would be treated as if it were a wholly-owned subsidiary of holding entity, Smiggins Co. Stapley Co would therefore be a subsidiary member of the consolidatable group headed by Smiggins Co.

**Example 3.5**

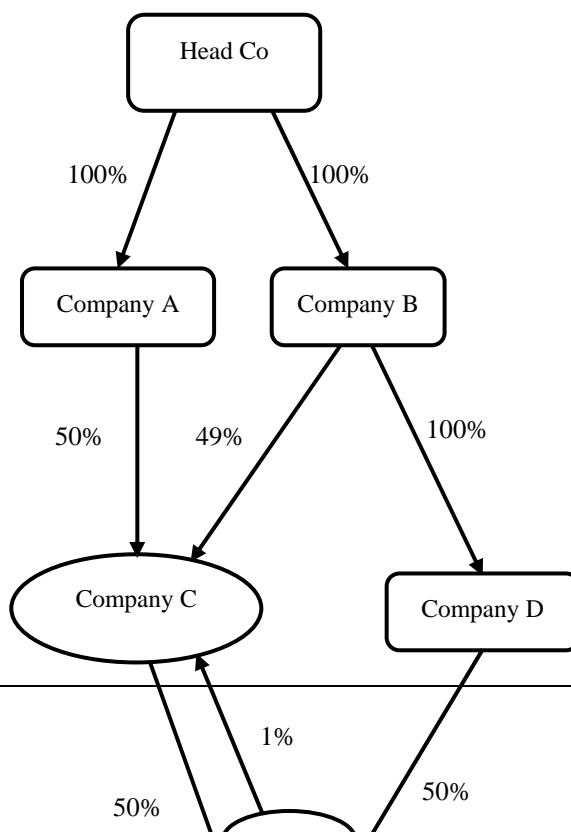

In this example, all of the entities are ordinary Australian resident companies (companies that are Australian residents and not prescribed dual residents, taxed at the general company tax rate and not subject to any concessions).

Company A and Company B are wholly-owned subsidiaries of holding entity, Head Co, as Head Co beneficially owns all of the membership interests in these companies.

Collectively, Company A and Company B beneficially own all of the membership interests in Company C, disregarding the shares beneficially owned in Company C that were issued under employee share acquisition arrangements. Thus, Company C is a wholly-owned subsidiary of holding entity, Head Co. Company D is also a wholly-owned subsidiary of Head Co as it is a wholly-owned subsidiary of Company B, which is a wholly-owned subsidiary of Head Co. This means that Company E is a wholly-owned subsidiary of holding entity, Head Co, too (because Company C and Company D together beneficially own all the membership interests in Company E, and are themselves wholly-owned subsidiaries of Head Co).

There are no entities interposed between Company C, Company D or Company E and Head Co that are ineligible to be subsidiary members of a consolidatable group headed by Head Co.

Therefore, a consolidatable group of entities exist consisting of Head Co as the head company and Company A, Company B, Company C, Company D and Company E as subsidiary members.

**Example 3.6.**

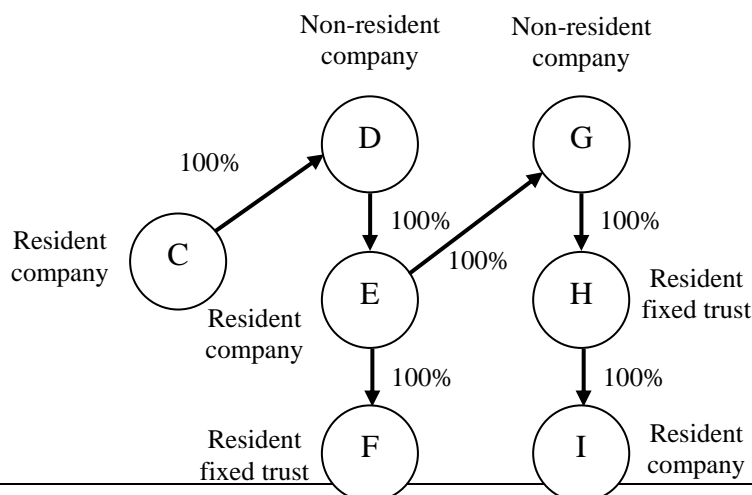



This example illustrates how the interposed foreign resident tests in paragraphs 3.83 and 3.84 are intended to operate.

C is an Australian resident company that beneficially owns 100% of the membership interests in D, a non-resident company. D in turn beneficially owns all of the membership interests in E, an Australian resident company.

E beneficially owns all of the membership interests in G, a non-resident company and is the only beneficiary of F, which is a resident fixed trust.

G is the only beneficiary of H, a resident fixed trust and beneficially owns all of the membership interests in I, an Australian resident company.

In this example it can be assumed that:

- C is eligible to be a head company of a consolidatable or consolidated group under subsection 703-15(3) item 1 in the table;
- E & I (Australian resident companies) and F & H (Australian resident fixed trusts ) satisfy the income tax treatment and Australian resident requirements under subsection 703-15(3) item 2 in the table that are prerequisite conditions for being a subsidiary member of a consolidatable or consolidated group. Being non-resident companies, D and G fail the later requirements and thus, these entities are unable to be subsidiary members of a consolidatable or consolidated group; and
- D, E, F, G, H and I are wholly-owned subsidiaries of head company, C. These entities therefore satisfy the first limb of the ownership requirements under subsection 703-15(3) item 2 in the table that need to be met in order to qualify as a subsidiary member of a consolidatable or consolidated group.

The remaining requirement relevant to determining whether E, F, H and I can qualify as subsidiary members of a consolidatable or consolidated group headed by C is therefore the second limb of the ownership requirements, specifically the interposed foreign resident tests outlined in paragraphs 3.83 and 3.84.

E satisfies the interposed foreign resident test in paragraph 3.83 because there is only one entity interposed between it and the head company, C, and that entity (D) is a foreign resident company. Further, E would otherwise qualify as a subsidiary member if it was assumed that D was a subsidiary member of the group. E is therefore eligible to be a subsidiary member of the consolidatable or consolidated group headed by C.

F satisfies the interposed foreign resident test in paragraph 3.84 as it would be a subsidiary member of the group if it was assumed that C (the head company) beneficially owned all of the membership interests

that were beneficially owned by E. F therefore qualifies as a subsidiary member of the consolidatable or consolidated group headed by C.

H does not meet the interposed foreign resident test in paragraph 3.84 because it would not be a subsidiary member of the group if it was assumed that C (the head company) beneficially owned all of the membership interests that were beneficially owned by E. H is therefore not eligible to be a subsidiary member. H cannot be a subsidiary member of the group because, as intra-group transactions within a consolidated group are ignored, it would not be possible to calculate the net income of the trust for the purpose of assessing the beneficiary, G, who would not be a member of the group.

I does not meet the interposed foreign resident test in paragraph 3.83 and consequently will also not qualify as a subsidiary member. I does not satisfy the interposed foreign resident test as there is a resident entity, H, interposed between it and C, the head company of the group, who is not a member of the group. Whilst the interposed foreign resident tests allow certain non-member entities to be interposed between the head company of the group and the test entity, each of those entities must be foreign resident entities.

Therefore, one consolidatable group (or consolidated group – if e.g., a choice under section 703-50 has been made by C) of entities exist consisting of C as the head company and E and F as subsidiary members. If H was instead a company, both H and I would satisfy the conditions in the interposed foreign resident tests and qualify as subsidiary members of the group too.

### **How does a head entity choose to consolidate a consolidatable group?**

3.87 A choice to consolidate a consolidatable group must be in the approved form and must specify a day (after 30 June 2002) from which the group will be consolidated. The company that makes the choice must have been the head company of the consolidatable group on the day specified in the choice. However, the company that makes the choice need not be the head company of the group when it gives the Commissioner the choice (unless the choice is given to the Commissioner on the day specified in the choice). [*Schedule 1, item 1, subsections 703-50(1) and (4)*]

3.88 The choice may be given to the Commissioner on any day within the period beginning on the day specified in the choice and ending on the day that the group's first consolidated income tax return is lodged. However, if there is no requirement to lodge this income tax return, the choice can be given to the Commissioner on any day within the period beginning on the day specified in the choice and ending on the last day within the period that lodgement of such an income tax return would have been required had there been a requirement to lodge this return. [*Schedule 1, item 1, subsection 703-50(3)*]

3.89 Once given to the Commissioner, the choice is irrevocable and remains effective until the consolidated group ceases to exist [*Schedule 1, item 1, subsections 703-50(2) and (4)*].

3.90 Further, the day specified in the notice of choice, from which the group will be consolidated, cannot be amended. [*Schedule 1, item 1, subsection 703-50(2)*]

3.91 A choice has no effect if the Commissioner is satisfied that the notice of choice contains information that is incorrect in a material particular. The Commissioner may nevertheless give effect to an incorrect choice of this type by giving the head company written notice that the choice is effective. [*Schedule 1, item 1, subsections 703-50(5) and (6)*]

3.92 A choice to consolidate under the ordinary membership rules for consolidated groups, the subject of this chapter, will have no effect where it is given by a company that could have made a choice to form a MEC group on the date specified in the choice (on or after which the group would otherwise have been treated as consolidated) [*Schedule 1, item 1, subsection 703-50(7)*]. The requirements for formation of a MEC group are discussed in Chapter 10.

## **Changes in membership of a consolidated group**

### ***Membership changes generally do not affect the existence of a consolidated group***

3.93 Consistent with the principle that the choice of a head company to consolidate is irrevocable, a change in the membership of a consolidated group will generally not affect the existence of that consolidated group. Generally, the same consolidated group will continue to exist so long as the same head company exists as a head company, unless the head company becomes eligible to be a member of a MEC group [*Schedule 1, item 1, subsection 703-5(2)*]. One exception to this rule that is currently under development is discussed in paragraph 3.19.

### ***Notice of changes in membership***

3.94 It is proposed that the head company will be required to notify the Commissioner of the following membership changes:

- entry of a new subsidiary member into a pre-existing consolidated group;
- exit of a subsidiary member from a consolidated group; and
- where the consolidated group ceases to exist.

3.95 The time frame within which the Commissioner must be notified of the above membership changes is still under consideration.

## **Application and transitional provisions**

3.96 In general these amendments will apply to groups that consolidate on or after 1 July 2002.

## **Consequential amendments**

3.97 Amendments consequential to the measures discussed in this chapter will be included in subsequent legislation.

---

# Chapter 4

## Asset rules

---

### Outline of chapter

4.1 The rules explained in this chapter deal with assets of subsidiary entities that join or leave a consolidated group. The acquisition or disposal of an entity by a consolidated group is treated like the acquisition or disposal of the assets of that entity. A group's cost of acquiring a subsidiary entity is treated as the cost of acquiring the subsidiary's assets. When a subsidiary entity ceases to be a member of the group, the group is recognised as having acquired the membership interests in the subsidiary for an amount equal to the group's cost for the net assets of that entity.

4.2 This chapter explains the rules for:

- subsidiary entities joining a consolidated group, including on group formation;
- subsidiary entities leaving a consolidated group; and
- special transitional provisions for consolidated groups that form, with effect, on or before 30 June 2003.

The chapter also contains illustrative examples of applications of those rules.

4.3 The cost setting rules explained in this chapter are modified in the case of a MEC group (refer to Chapter 10 for an explanation of the modifications).

4.4 The rules relating to a single entity joining a consolidated group and for entities leaving a consolidated group are contained in Subdivision 705A and Division 711 respectively of Schedule 1 of the accompanying exposure draft. This Subdivision and Division provide examples of how the remaining rules will be drafted using a more streamlined approach to the rules than was adopted in the December 2000 exposure draft.

### Context of reform

4.5 The treatment of assets of entities joining a consolidated group is based on the asset-based model discussed in *A Platform for Consultation* and recommended by *A Tax System Redesigned*.

4.6 This model treats the acquisition or disposal of an entity by a consolidated group as the acquisition or disposal of the assets of that

entity. This prevents the double taxation of gains and duplication of losses within a consolidated group and allows for assets to be transferred between members of the consolidated group without requiring cost base adjustments to address value shifting.

## **Summary of new law**

### **Entities joining or becoming a consolidated group**

4.7 There are 4 cases for joining and in each there are tax consequences for both the joining entity and the head company. The cases are:

- a single entity joining an existing consolidated group;
- forming a consolidated group;
- an existing consolidated group joining another consolidated group; and
- multiple entities linked through membership interests joining a consolidated group.

4.8 In addition, there are rules for making subsequent corrections to the cost to a group of acquiring the assets of an entity.

#### ***An entity joining an existing consolidated group***

4.9 When an existing consolidated group completes the acquisition of an eligible entity, the acquired entity becomes a subsidiary member of the consolidated group and the cost of acquiring the entity (allocable cost amount) is treated as the cost of acquiring the entity's assets. The deemed payment for each of the assets is worked out by allocating the allocable cost amount for the acquired entity among the entity's assets. The deemed payment for each asset provides a basis for determining the 'cost' of the asset for CGT, trading stock and capital allowance purposes.

4.10 The consolidated group's allocable cost amount for a joining entity consists of the group's cost of acquiring the membership interests in the joining entity and the amount of liabilities of the joining entity at the joining time. The allocable cost amount also reflects certain retained earnings, distributions and losses of the joining entity.

4.11 This case provides the basic rules for determining the cost of the assets of a joining entity to a consolidated group. The other cases operate by modifying these rules.

---

***Forming a consolidated group***

4.12 The rules applying when a consolidated group is formed are, subject to required modifications, the same as the rules applying when an entity joins an existing consolidated group. Each entity that becomes a subsidiary member of the consolidated group at the time the group is formed is treated in the same way as an entity joining an existing consolidated group.

4.13 When a consolidated group is formed, no changes are made in relation to the assets of the head company of the group, except that all intra-group membership interests and debts, including those held by the head company, cease to be recognised for income tax purposes after the formation of the group because of the single entity rule (discussed in Chapter 2).

***A consolidated group joining an existing consolidated group***

4.14 The acquisition by a consolidated group of another consolidated group is treated as though the acquired group were a single entity. That is, the cost of acquiring the acquired group is treated as the cost of acquiring all its assets. Some modifications to the rules for a single entity joining a consolidated group are required to achieve this.

***Multiple entities linked through membership interests join an existing consolidated group***

4.15 Completion of the group's acquisition of the membership interests of an eligible entity will cause that entity and all eligible entities that are wholly-owned by that entity alone, or by that entity jointly with existing members of the consolidated group, to immediately become members of the consolidated group. As with the preceding cases, the rules for a single entity joining a group are modified for determining the consolidated group's deemed payments for the assets of all of these joining entities.

***Rules for making subsequent corrections to the cost to a group of acquiring the assets of an entity***

4.16 An alternative to normal amendment action to make corrections to the allocable cost amount in later years is provided to reduce compliance costs. The method applies to correct:

- errors in determining the aggregate cost allocated to the assets of a subsidiary member; and
- differences between the settled amounts of the liabilities of a subsidiary member and the amounts taken into account when determining the group's cost of acquiring the member.

4.17 This alternative provides that the error or difference is reflected as a capital gain or loss to the head company.

### **Entities leaving a consolidated group**

4.18 When an entity leaves a consolidated group there are tax consequences for both the group head company and for the leaving entity.

4.19 Immediately before an entity leaves a consolidated group, the head company is deemed to have acquired the membership interests in the leaving entity for a payment that reflects the group's cost of acquiring the net assets of the leaving entity.

4.20 The leaving entity is treated as having acquired its assets on leaving the group for a payment for each asset that, if it had been received by the group, would have resulted in a tax-neutral disposal of the asset by the group.

4.21 Where a leaving entity holds membership interests in one or more other subsidiary members of the group, those entities also will be ineligible to remain in the group. The rules for a single entity leaving are adapted to determine costs for membership interests in all such leaving entities and to provide each leaving entity with a cost for the assets it takes with it from the group.

### **Transitional rules**

4.22 The transitional measures are primarily to reduce the compliance costs associated with forming a consolidated group.

4.23 Where a consolidated group is formed, with effect, before 1 July 2003, the head company may choose that assets of subsidiary members that were wholly-owned subsidiaries of the head company at 1 July 2002, retain their 'costs' for tax purposes (e.g. adjustable values). This choice enables existing groups to consolidate without valuing the assets of, or calculating allocable cost amounts for, subsidiary members.

### **Comparison of key features of new law and current law**

<i>New law</i>	<i>Current law</i>
Acquisition or disposal of an entity by a consolidated group is treated as an acquisition or disposal of the assets of that entity.	Acquisition or disposal of an entity by a holding company is dealt with only as an acquisition or disposal of membership interests in the entity.



---

## Detailed explanation of new law

### Entities joining or becoming a consolidated group

4.24 The 4 cases for joining are:

- a single entity joining a consolidated group (see paragraphs 4.26 to 4.103);
- the formation of a consolidated group (see paragraphs 4.104 to 4.126);
- an existing consolidated group joining another consolidated group (see paragraphs 4.127 to 4.131); and
- multiple entities linked through membership interests joining a consolidated group (see paragraphs 4.132 to 4.138).

4.25 When an entity (the joining entity) becomes a member of a consolidated group (the joined group) it is generally treated for income tax purposes as having been subsumed in the head company.

#### *What happens when an entity joins an existing consolidated group?*

4.26 There are implications for both the joining entity and the head company.

#### *Treatment of a joining entity*

4.27 There are generally no income tax consequences for the joining entity. There are specific rules for the trading stock of the joining entity to achieve this (see paragraph 2.29).

4.28 One income tax consequence for a joining entity relates to an assessable recoupment. The market value of an asset that is a 'right to recoupment' (and is recognised under accounting principles in the balance sheet of a joining entity at the joining time) that would be included in assessable income when the amount of recoupment is received, is assessable income of the joining entity in its return for the period up to the joining time even though not yet received at that time.

4.29 The entry clean slate rule, which is currently being reviewed (see paragraphs 2.35 to 2.41), will ensure that any recoupment received by the head company relating to a tax deductible outgoing incurred by the joining entity, will not be assessable income of the head company. The receipt of the recoupment by the head company will replace the asset 'right to recoupment' recognised at the joining time and any difference will give rise to a capital gain or loss.

4.30 Another income tax consequence for a joining entity relates to deferred primary production income. Division 385 of the ITAA 1997 allows certain primary production income received in one income year to be deferred or spread over a number of years. If not all of this income has been included in assessable income when an entity joins a consolidated group, the amount of unreturned income will be included in the joining entity's assessable income for the period up to the joining time. This is because the single entity rule causes the entity to cease to exist as a separate tax entity at the joining time. Subsection 385-163(1) will apply with the result that a 'disentitling event' for the purpose of Subdivision 385-H will occur at the joining time.

#### *Treatment of a head company*

4.31 The treatment for a head company falls into 3 main parts:

- allocation of the cost of acquiring a joining entity to the assets that entity brings to the consolidated group (the deemed payment for the assets of the joining entity – see paragraphs 4.32 to 4.63);
- working out the cost of acquiring the joining entity (the allocable cost amount – see paragraphs 4.64 to 4.98); and
- preservation of the pre-CGT status of membership interests in the joining entity (see paragraphs 4.99 to 4.103).

#### Deemed payments for the assets of the joining entity

4.32 The joined group's cost of acquiring the joining entity is treated as the head company's cost of acquiring its assets – the head company is deemed to have made a payment for each of the assets of the joining entity when the entity becomes a subsidiary member of the group (the joining time). This establishes the head company's time and cost of acquisition for each asset.

4.33 The amount of the deemed payment for an asset will be the relevant 'cost' for all income tax purposes including for the purposes of the CGT, capital allowance and trading stock provisions.

4.34 The elements for determining the deemed payment for each asset are:

- deeming a payment for the *retained cost base assets*, by reference to their *terminating value* (see paragraphs 4.35 to 4.41);
- deeming a payment for the *reset cost base assets* (see paragraphs 4.42 to 4.63), taking account of special rules for:
  - *goodwill* (see paragraphs 4.44 to 4.46);

- *revenue assets* (see paragraphs 4.47 to 4.51);
- *accelerated depreciation* (see paragraphs 4.52 and 4.53);  
and
- *over-depreciated assets* (see paragraphs 4.54 to 4.63).

### **Retained cost base assets**

4.35 To simplify compliance, the head company's deemed payment for certain assets (retained cost base assets) is set equal to the joining entity's cost for those assets.

4.36 A *retained cost base asset* is Australian currency or a right to receive a specified amount of Australian currency, other than a right that is a marketable security within the meaning of section 70B of the ITAA 1936. However, assets that are Australian currency and that are trading stock or collectables of the joining entity are not retained cost base assets. [*Schedule 1, item 1, subsection 705-20(4)*]

4.37 The amount treated as the payment for each retained cost base asset of the joining entity is the amount of Australian currency concerned. This will avoid the compliance costs that would arise in dealing with these assets if their 'cost' was set at an amount that was different to their nominal value. [*Schedule 1, item 1, subsection 705-20(1)*]

4.38 If a retained cost base asset is a debt owed to the joining entity and at the joining time it is expected that the full amount of the debt will not be repaid (e.g. doubtful debts), the amount treated as the payment for the debt is instead the amount of the debt that could reasonably be expected to be repaid. This reflects the value that would be attached to the debt in a non-incremental acquisition (i.e. the whole of the membership interests are acquired in a single transaction) of the joining entity at the joining time. [*Schedule 1, item 1, subsection 705-20(2)*]

4.39 If a retained cost base asset is a qualifying security within the meaning of Division 16E of Part III of the ITAA 1936, the amount treated as the payment for it is instead the joining entity's terminating value for the security. This is an amount such that if the joining entity were to dispose of the security for that amount at the joining time, it would cause neither an amount to be added to the assessable income of, nor a deduction to be allowed to, the joining entity. [*Schedule 1, item 1, subsection 705-20(3)*]

4.40 If the total amount to be treated as payment for retained cost base assets of the joining entity exceeds the joined group's allocable cost amount for the joining entity, the head company of the consolidated group will make a capital gain equal to the excess. Rules to provide the CGT event under which the capital gain will arise are still to be developed.

#### Terminating value of an asset of a joining entity

4.41 The *terminating values* of assets of a joining entity are relevant for the head company's cost base for reset cost base assets that are qualifying securities within the meaning of Division 16E of Part III of the ITAA 1936 (see paragraph 4.39), over-depreciated assets (paragraphs 4.57 and 4.58) and for step 6 in working out the allocable cost amount in relation to a joining entity (paragraphs 4.94 and 4.95). A joining entity's terminating values for assets of different types are set out in Table 4.1. [Schedule 1, item 1, section 705-25]

**Table 4.1: Terminating value of an asset of a joining entity**

<i>If an asset of the joining entity is...</i>	<i>The terminating value of the asset is...</i>
Trading stock that was on hand at the beginning of the income year ending at the joining time.	The value at which it was taken into account by the joining entity at that time under Division 70 of the ITAA 1997.
Trading stock that was acquired by the joining entity during that income year.	the amount of the outgoing incurred by the joining entity in connection with the acquisition of the trading stock or, if there was no such outgoing, nil.
A depreciating asset.	Its adjustable value at the joining time.
A qualifying security (within the meaning of Division 16E of Part III of the ITAA 1936) that is not trading stock.	The amount of the consideration that the joining entity would need to receive if it were to dispose of the asset just before the joining time in order for no amount to be included in, or deductible from, the joining entity's assessable income under section 159GS of the ITAA 1936.
A CGT asset that is neither trading stock nor a depreciating asset.	Its cost base at the joining time.
Any other asset.	The amount that would have been its cost base at the joining time if it were a CGT asset.

#### Reset cost base assets

4.42 A *reset cost base asset* is any asset that is not a retained cost base asset. [Schedule 1, item 1, section 705-30]

4.43 The amount treated as the payment for each reset cost base asset of the joining entity is worked out in 3 steps:

- step 1 – determine the joined group’s allocable cost amount for the joining entity (discussed in paragraphs 4.64 to 4.95);
- step 2 – the allocable cost amount is reduced by the total of the payments for the retained cost base assets, but not below zero. If the result of this step is zero, then the amount treated as the payment for each reset cost base asset is zero; and
- step 3 – the remaining allocable cost amount is allocated to each of the joining entity’s reset cost base assets in proportion to their market values. If there are no reset cost base assets, the result of step 2 is instead treated as a capital loss of the head company. Rules to provide the CGT event under which the capital loss will arise are to be developed.

#### Example 4.1

On 1 July 2002, Head Co, the head company of a consolidated group, completed the acquisition of the membership interests in D Co. This causes D Co to join the consolidated group. At that time, D Co’s assets are \$100 cash (a retained cost base asset) and 2 reset cost base assets – Asset A (market value \$300) and Asset B (market value \$200).

The deemed purchase payments for the assets brought into the group by D Co are worked out as follows:

*Firstly*, the group’s allocable cost amount for D Co is worked out. Suppose this is \$500. (The difference between this cost (\$500) and the market value of the assets (\$600) would be accounted for by unrealised appreciation of the assets accruing to membership interests already held by Head Co before the completion of Head Co’s acquisition of D Co.)

*Secondly*, the deemed purchase payment for D Co’s retained cost base asset (the \$100 cash) is \$100. The allocable cost amount (\$500) is reduced by the deemed purchase payments for the retained cost base assets (\$100), leaving \$400 for allocation to the reset cost base assets.

*Finally*, the \$400 is allocated to the reset cost base assets in proportion to their market values. For Asset A, the amount allocated is \$240 ( $\$300 / \$500 \times \$400$ ). For Asset B, the amount allocated is \$160 ( $\$200 / \$500 \times \$400$ ).

The deemed payments for the deemed purchase of Asset A and Asset B by Head Co are \$240 and \$160 respectively.

## Goodwill

4.44 Any 'goodwill' accruing to the group as a consequence of its ownership and control of the joining entity will be added to any reset cost base asset (goodwill) of the joining entity. It will be deemed to have been purchased by the head company at the joining time and will, as for other reset cost base assets, have an amount determined as the payment for its deemed purchase. This amount will effectively provide a basis for determining the cost base of the goodwill for CGT purposes.

4.45 The market value of an entity can reflect its potential to add to the value of the existing assets of potential acquirers. Therefore, the market value of the whole of this goodwill can be taken as the amount of any excess of the market value of the joining entity at the joining time over the market value of the net identifiable assets of the joining entity at that time. It is, therefore, appropriate to treat goodwill as a reset cost base asset of the entity even though some of the added value may accrue to assets or businesses already owned by the joined group. [*Schedule 1, item 1, subsection 705-30(2)*]

### Example 4.2

On 1 July 2002, Head Co, the head company of an existing consolidated group, acquired all of the membership interests in Z Co. This causes Z Co to join the consolidated group.

At that time, the market value of Z Co's net identifiable assets (excluding goodwill) is \$1 million. However, the market value of Z Co is determined to be \$1.5 million. At the time Z Co joins the consolidated group, goodwill with a market value of \$500,000 is treated as a CGT asset of Z Co.

4.46 The treatment of goodwill when an entity leaves a consolidated group is discussed in paragraph 4.173.

### Restriction on deemed payment for revenue assets

4.47 The amount treated as the payment for the deemed purchase of a reset cost base asset may be restricted in certain circumstances. The restriction addresses the potential for unrealised capital losses to be converted to revenue losses when an entity joins a consolidated group. This relates to situations where assets still held by a joining entity have declined in value after the group it is joining purchased membership interests in it.

4.48 The restriction applies to reset cost base assets that, after the joining time, are effectively treated for income tax purposes on revenue account (e.g. trading stock and depreciating assets). [*Schedule 1, item 1, subsection 705-35(1)*]

4.49 The restriction applies where the payment worked out for the deemed purchase of the asset exceeds both the market value of the asset and the joining entity's terminating value for the asset (see paragraph 4.41). In these circumstances, the deemed purchase payment is reduced to the greater of those 2 amounts. [*Schedule 1, item 1, subsection 705-35(2)*]

4.50 The amount by which the payment is reduced is then allocated to each of the reset cost base assets whose deemed payment has not been reduced under the restriction. The allocation is in proportion to the market values of those assets. The deemed payments of each of those assets is increased by the amount allocated to it. [*Schedule 1, item 1, subsection 705-35(3)*]

### Example 4.3

Headco, the head company of a consolidated group, purchased 90% of the membership interests in Ayco for \$90 when Ayco had trading stock with a market value of \$10 and land with a market value of \$90. Subsequently the land declined in value and when Headco purchased the remaining membership interests, for \$8, Ayco had trading stock with a market value of \$20 and land with a market value of \$60.

Upon the completion of the acquisition of Ayco, Ayco becomes a subsidiary member of Headco's consolidated group. Headco's allocable cost amount for Ayco is \$98, comprised solely of the cost of acquiring the membership interests. If the allocable cost amount were allocated to the assets Ayco brings to the group in proportion to their market values, the deemed payments for the assets would be:

<i>Asset</i>	<i>Market Value (\$)</i>	<i>Deemed Payment (\$)</i>
Trading stock	20	24.50
Land	60	73.50
<b>Total</b>	<b>80</b>	<b>98.00</b>

However, the deemed payment for trading stock cannot exceed the greater of its market value or Ayco's terminating value for it. Supposing the market value is greater, this rule requires that the deemed payment for the trading stock be reduced by \$4.50. This amount can be added to the deemed payment for the land. Headco's deemed payments for the assets brought to the group by Ayco become \$20 for the trading stock and \$78 for the land.

4.51 If the deemed payments for all of the reset cost base assets of the joining entity are reduced by the restriction, the head company of the joined group makes a capital loss equal to the total amount by which the allocable cost amount cannot be allocated. Rules to provide the CGT event under which the capital loss will arise are to be developed.

#### Reduction in deemed payment for accelerated depreciation assets

4.52 An exception to the entry clean slate rule allows the head company to continue to claim accelerated depreciation in respect of a depreciating asset of the joining entity, where the joining entity was entitled to accelerated depreciation (see paragraph 2.43).

4.53 The deemed payment for the asset by the head company must not be more than the joining entity's terminating value for that asset. The head company can choose to reduce the deemed payment for the depreciating asset to the joining entity's terminating value for that asset. Where this occurs, the excess payment amount is not allocated to other assets of the joining entity. [*Schedule 1, item 1, section 705-40*]

#### Over-depreciated assets and the intercorporate dividend rebate

4.54 In certain circumstances there may be a reduction to the amount of the deemed payment that would otherwise apply to over-depreciated assets of the joining entity. An asset is **over-depreciated** at a particular time if there has been some depreciation (i.e. a reduction in its adjustable value) and its market value *exceeds* its adjustable value. The amount of over-depreciation of the asset is the excess of its market value or its original cost, whichever is less, over its adjustable value. [*Schedule 1, item 1, subsection 705-45(5)*]

4.55 The reduction applies to prevent an increase in the adjustable value of a depreciating asset under the rules for consolidation where there has been tax deferral resulting from the over-depreciation of the asset. Without the reduction, the rules for consolidation would permit an increase in the adjustable value of an asset despite its over-depreciation resulting in tax deferral of indefinite duration.

4.56 The potential for indefinite deferral arises where a company held an asset that was over-depreciated and income sheltered from tax by over-depreciation was distributed as an unfranked dividend to a recipient that was entitled to the intercorporate dividend rebate. This can occur where the company becomes a subsidiary member of a consolidated group on or before 30 June 2002 (or at the first ending of the income year after that date for head companies with SAPs – the *SAP alternative*). It can also occur where the company becomes a member of a consolidated group after 30 June 2002 (or the *SAP alternative*) where:

- the asset is held continuously by the company from 30 June 2002 (or the *SAP alternative*) until its joining time; and
- the asset remains over-depreciated at the joining time.



This last condition is required because the over-depreciation of an asset continues to be a net shelter from income tax only so long as the asset continues to be over-depreciated. Over-depreciation of an asset can be diminished through time through deductions for depreciation that are lower than they would have been but for the earlier over-depreciation, or eliminated by a balancing adjustment on the disposal of the asset.

4.57 Consistent with the rationale outlined in paragraph 4.55, a reduction in the payment for an asset applies where:

- the head company's deemed payment for the asset (its cost for depreciation purposes) is more than its adjustable value to the joining entity at the joining time (the terminating value) [*Schedule 1, item 1, paragraph 705-45(2)(a)*];
- the joining entity paid an unfranked dividend during the period between when it acquired the asset and its joining time or 30 June 2002 (or the SAP alternative), whichever is earlier [*Schedule 1, item 1, paragraph 705-45(2)(b)*];
- an amount representing the unfranked dividend had not been, subsequently but before the joining time, paid as a dividend to a recipient that was not entitled to the intercorporate dividend rebate [*Schedule 1, item 1, paragraph 705-45(2)(c)*]; and
- the dividends were paid out of profits that were sheltered from income tax, at least in part, by over-depreciation of the asset [*Schedule 1, item 1, paragraph 705-45(2)(d)*].

4.58 The amount of the reduction is either:

- the amount of income that continues to be sheltered from tax; or
- the amount by which the deemed payment would, apart from this provision, exceed the joining entity's terminating value of the asset,

whichever is less. [*Schedule 1, item 1, subsection 705-45(2)*]

4.59 A further provision will prevent double deduction for any amount of unfranked dividend paid by the joining entity. This provision will prevent an unfranked dividend being taken into account in reducing the head entity's payment for an over-depreciated asset to the extent that that dividend had formed part of any amount deducted at step 4 in working out the allocable cost amount for the joining entity (paragraphs 4.86 to 4.88).

#### **Example 4.4**

Prior to 1 July 2002, T Ltd and U Ltd each contributed \$50 to capitalise K Co. K Co applied the \$100 to acquire a depreciating asset and generated cash flow income of \$40. K Co claimed depreciation of \$40 for income tax but its depreciation for financial reporting purposes was \$10. This enabled K Co to pay an unfranked dividend of \$30 which was shared equally between T Ltd and U Ltd. On 1 July 2002 T Ltd formed a consolidated group and on 1 January 2003 it purchased U Ltd's stake in K Co for \$50 (representing 50% of the market value of K Co's depreciating asset (\$90) plus K Co's cash (\$10)).

T Ltd does not elect under the transitional measures to replace the deemed purchase payment for K Co's asset with the asset's terminating value for the joining entity (see paragraphs 4.200 to 4.202). T Ltd's allocable cost amount for K Co is \$100, which is comprised wholly of its cost for membership interests. This allocable cost amount is allocated \$10 for T Ltd's deemed acquisition of K Co's cash and, in the first instance, \$90 for the depreciating asset.

The adjustment to the deemed payment for the depreciating asset to limit tax deferral would be the least of:

- the lesser of the amount of over-depreciation at the time of consolidation or at 1 July 2002 (i.e. in this example both amounts are equal to \$30 (\$90 – \$60));
- the excess of the amount that would otherwise be the deemed payment for the asset over its existing adjustable value (i.e. \$30 (\$90 – \$60)); and
- unfranked dividends paid by K Co before 1 July 2002 on which tax has not subsequently been paid (i.e. \$30 (\$15 to T Ltd and \$15 to U Ltd)).

In this case, all 3 amounts are the same, that is, \$30, so T Ltd's deemed payment for the depreciating asset is reduced from \$90 to \$60.

As a transitional measure, T Ltd can elect that an amount up to the \$30 reduction be added back to the terminating value of this asset for the head company, for the purpose of determining the deemed payment for the purchase of membership interests in an entity that owns the asset when it leaves the consolidated group (see paragraphs 4.216 and 4.217).

4.60 A reduction in the deemed payment may also apply where the asset has been received by the joining entity subject to rollover and the transferor paid dividends that were sheltered from tax because of over-depreciation of the asset in its hands. [*Schedule 1, item 1, subsection 705-45(3)*]

4.61 A reduction may also apply in relation to an asset held by the joining entity where:

- the asset had been an over-depreciated asset of another consolidated group that formed before 1 July 2003;
- because of a choice made under the transitional rules (see paragraphs 4.216 and 4.217), some or all of the original reduction for over-depreciation was added back for the purpose of working out the group's original cost for its membership interests when the joining entity left the other consolidated group;
- the asset was held by the joining entity when it left the other consolidated group and was continuously held by the joining entity from the time it left the other consolidated group until the joining time; and
- the asset was over-depreciated at the current joining time.

*[Schedule 1, item 1, subsection 705-45(4)]*

4.62 The amount of any reduction in this case is the lesser of:

- the amount of the prior reduction that was added back when the joining entity left the original consolidated group; or
- the amount of over-depreciation at the current joining time.

4.63 In the circumstances outlined in paragraph 4.61, the income originally sheltered from tax will not be taxed to the original consolidated group when it disposes of the entity holding the asset. This is because the group is able to elect to use a terminating value for the asset that disregards adjustments for sheltered income in determining the group's deemed payment for the membership interests in the leaving entity. Therefore, to limit the tax deferral, adjustments for income sheltered from tax may still be required when the joining entity joins the latter consolidated group.

What is the joined group's allocable cost amount for a joining entity?

4.64 The joined group's **allocable cost amount** for a joining entity determines the deemed payments made to acquire the assets of the joining entity. The amount reflects the cost to the joined group of acquiring the assets of the joining entity (see discussion of the cost setting rules in Chapter 2). That cost consists of the group's cost of acquiring the membership interests in the joining entity and the liabilities of the joining entity at the joining time. Adjustments are made to reflect certain undistributed profits, distributions and losses of the joining entity.

4.65 The joined group's allocable cost amount for a joining entity is worked out in 6 steps which are discussed in paragraphs 4.66 to 4.95 [*Schedule 1, item 1, section 705-50*]. Where a consolidated group acquires the whole of the membership interests in an entity in a single transaction (a non-incremental acquisition), only steps 1, 2 and 6 can apply. Steps 3, 4 and 5 make adjustments to the allocable cost amount for profits that accrue, distributions made and losses that accrue to membership interests owned by the acquiring consolidated group prior to the joining time. Therefore, these steps only apply where the acquisition of membership interests in an entity by a consolidated group occurs over time (an incremental acquisition). Steps 3 to 5 can also apply where there is an interval of time between the formation of a wholly-owned group and the time from which the head company chooses that the group be taxed as a consolidated group (deferred consolidation).

**Step 1: Determine the cost base of membership interests in the joining entity**

4.66 The first step in determining a group's allocable cost amount for a joining entity is to add up the 'costs' for all of the membership interests in the joining entity that are held by members of the group joined. The 'cost' used for each membership interest is the amount that would be the cost (the relevant cost) for determining the CGT outcome if the membership interest were disposed of at the joining time. This amount reflects part of the group's cost of acquiring the joining entity's assets. [*Schedule 1, item 1, subsection 705-55(1)*]

4.67 If, at the joining time, the market value of a membership interest is greater than or equal to its cost base, the cost base is the relevant cost. Otherwise, the relevant cost is the greater of the market value of the interest or the reduced cost base of the interest.

4.68 This single cost base will limit the circumstances where assets of a consolidated group will have a reduced cost base that is different from their cost base.

4.69 The reduced cost base of a membership interest, to be used for recognising a single cost base for membership interests, should be increased by any reduction to this cost base previously made under subsection 110-55(7) of the ITAA 1997 for distributions of certain profit. This is done in order to prevent this adjustment being made twice. That is, the allocable cost amount is also reduced in step 4 for any distributions of profit in excess of profits accruing directly or indirectly to the head company (see paragraphs 4.86 to 4.88).

4.70 Where, at the joining time, there are outstanding cost base adjustments for membership interests, the cost base to be used when recognising a single cost for membership interests is the cost base after making those adjustments. The cost base adjustments may be required because of, for example, an earlier loss or asset transfer or a value shift. *[Schedule 1, item 1, subsection 705-55(2)]*

4.71 As these outstanding cost base adjustments are brought to account at the joining time, the provisions requiring these adjustments will have no further application in relation to membership interests in the joining entity. *[Schedule 1, item 1, subsection 705-55(3)]*

4.72 Examples of provisions under which relevant cost base adjustments may be required at the joining time are set out in Table 4.2.

**Table 4.2: Provisions under which cost base adjustments may be required**

<i>Provision</i>	<i>What the provision is about</i>
Section 170ZP of the ITAA 1936.	Transfers of net capital losses within company groups.
Division 19A of Part IIIA of the ITAA 1936.	Transfers of assets between companies under common ownership.
Division 19B of Part IIIA of the ITAA 1936.	Share value shifting arrangements.
Division 138 of the ITAA 1997.	Value shifts between companies under common ownership.
Division 139 of the ITAA 1997.	Value shifting through debt forgiveness.
Division 140 of the ITAA 1997.	Share value shifting.
Subdivision 170-B of the ITAA 1997.	Transfers of net capital losses within wholly-owned groups of companies.
Subdivision 170-C of the ITAA 1997.	Transfers of tax losses and net capital losses within wholly-owned groups of companies.

4.73 If some or all of the membership interests in the joining entity are pre-CGT assets of members of the joined group, the cost base of those interests is worked out in the same way as for post-CGT assets.

## Step 2: Add liabilities of the joining entity

4.74 The second step in determining a group's allocable cost amount for a joining entity is to add an amount for the joining entity's liabilities. The joining entity's liabilities reflect part of the cost to the group of acquiring the joining entity's assets, because the liabilities effectively become liabilities of the group.

4.75 The amount is worked out by adding up all of the joining entity's liabilities at the joining time that, in accordance with accounting standards or statement of accounting concepts made by the Australian Accounting Standards Board, can or must be identified in the reports of the entity's balance sheet. *[Schedule 1, item 1, subsection 705-60(1)]*

4.76 The accounting standards and statements of accounting concepts may not apply to all entities. However, if an entity joins a consolidated group then it is necessary to identify the relevant liabilities by reference to those liabilities that can or must be identified under the accounting standards or statement of accounting concepts. This requirement enables consistent rules to be applied in determining the allocable cost amount for all entities that join a consolidated group.

4.77 If some or all of a liability will be a deduction to the head company when the liability is discharged, the amount of the liability to be taken into account is reduced by the amount that will be a deduction multiplied by the general company tax rate. *[Schedule 1, item 1, subsection 705-60(2)]*

4.78 An amount is not to be added as a liability if it arises because of the joining entity's ownership of an asset, and on disposal of the asset, the liability will transfer to the new owner. The amount of such a liability should be taken into account in working out the market value of the asset when allocating the allocable cost amount for the joining entity to the assets of the joining entity. An example of such a liability would be a liability to rehabilitate a mine site, where under legislation or license, the liability will transfer to the new owner on disposal of the mine. *[Schedule 1, item 1, subsection 705-60(3)]*

4.79 If a liability of the joining entity is a debt or other liability owed to the joined group, and the group's cost base in respect of the debt or liability is less than the amount of the joining entity's liability, the amount to be added for the liability is instead equal to the group's cost base. *[Schedule 1, item 1, subsection 705-60(4)]*

4.80 Where a liability, or a change in the amount of a liability, is taken into account, under generally accepted accounting principles sooner than occurs for income tax *and* this results in the amount of the allocable cost amount being different than if it were taken into account for income tax, the amount of the liability is adjusted to reflect the amount of the liability that would be taken into account for income tax purposes at that earlier time. Examples of such liabilities are employee's accrued entitlements to

paid leave and liabilities that are designated in a foreign currency.  
*[Schedule 1, item 1, subsection 705-60(5)]*

#### **Example 4.5**

M Co, the head company of a consolidated group, acquires 80% of the membership interests in N Co for \$80 when N Co's only asset is the goodwill of a business which has a market value of \$100. After operating for an income year, N Co breaks even on cash account but accrues a liability of \$5 for employee's accrued leave entitlements. M Co then acquires the remaining 20% of the membership interests in N Co for \$19. N Co then becomes a member of M Co's consolidated group.

M Co's allocable cost amount for N Co is \$100, comprised of \$99 for the cost base of membership interests (step 1 in working out the allocable cost amount) and \$1 for liabilities (step 2). The amount for liabilities is \$1 because 80% of the liability for accrued leave, if settled by N Co as it accrued, would have resulted in a loss that would have been deducted at step 5 (see paragraphs 4.89 to 4.92) in working out the allocable cost amount.

The whole of the allocable cost amount is allocated to the goodwill which is N Co's only asset.

#### **Example 4.6**

S Co, the head company of a consolidated group, acquires 90% of the membership interests in T Co for \$9 when T Co has assets with a market value of \$100 and a foreign currency liability with an Australian currency value of \$90. During the remainder of its income year, T Co has neither taxable income nor a tax loss and, due to a movement in the exchange rate, the Australian currency value of its foreign exchange liability decreases to \$80. S Co then acquires the remaining membership interests in T Co for \$1.70 (T Co has an asset with a market value of \$100, a foreign exchange liability with an Australian currency value of \$80 and an exposure to income tax of \$3 – assuming a 30% rate – on the decline in the Australian currency value of the foreign exchange liability) and T Co becomes a subsidiary member of S Co's consolidated group.

Therefore, S Co's allocable cost amount for T Co is \$100, comprised of:

- \$10.70 for cost base for membership interests (step 1 in working out allocable cost amount); and
- \$89.30 for liabilities (step 2).

\$9.30 of the \$10 decline in the Australian currency value of the foreign exchange liability is added back because, if the liability had been realised just before the joining time, it would have caused an increase in another liability (for income tax – \$3 at a 30% rate) and an increase in the amount of frankable undistributed profits accruing to S Co's

continuously held membership interests (\$6.30 (90% × \$7)) added at step 3 – see paragraphs 4.84 and 4.85.

Therefore, there is no change to the aggregate cost base for S Co’s assets.

4.81 Where there are employee shares in the joining entity that are disregarded in determining whether the joining entity is a wholly-owned subsidiary of the head company, those shares are treated as a liability of the joining entity at an amount equal to the market value of those shares. *[Schedule 1, item 1, subsection 705-60(6)]*

4.82 The amount added at step 2 for disregarded employee shares will be reduced where the employee shares were issued after the joined group acquired membership interests in the joining entity. These interests are not treated as liabilities because they represent part of the price paid by the head company for its interest in the assets of the joining entity which were subsequently paid to employees. This rule also only applies if the market value of the employee share interests exceeds the consideration paid for their acquisition by the employees. *[Schedule 1, item 1, subsection 705-60(7)]*

4.83 The amount of the reduction is determined by the following formula:

$$\frac{\text{market value of head company's membership interest}}{\text{market value of all membership interests}} \times \frac{\left[ \begin{array}{l} \text{market value of} \\ \text{employee share} \\ \text{interests at time} \\ \text{of acquisition} \end{array} \right] - \left[ \begin{array}{l} \text{consideration paid or} \\ \text{given for acquisition} \\ \text{of employee share} \\ \text{interest} \end{array} \right]}{\text{market value of employee share interest at time of acquisition}}$$

where:

- **market value of head company’s membership interests** is the market value, just before the employee share interest was acquired by the employee, of any membership interests that the head company held, directly or indirectly in the joining entity, continuously from that time until the joining time.
- **market value of all membership interests** is the market value of all membership interest in the joining entity just before the employee share interest was acquired.



---

**Step 3: Add undistributed, frankable pre-joining time profits accruing to continuously held membership interests**

4.84 The third step in determining a group's allocable cost amount for a joining entity is to add the sum of fully frankable dividends the joining entity would be able to pay out of its undistributed profits that have accrued to the membership interests that were (directly or indirectly) owned by the head company. The time at which this is determined is when the profits accrued, and the membership interests must have been continuously (directly or indirectly) owned by the head company since that time. The purpose of this step is to prevent double taxation by allowing the consolidated group a cost for retained taxed or taxable profits that accrued to membership interests when the membership interests were owned by the consolidated group (as can occur where there is an incremental acquisition of an entity). *[Schedule 1, item 1, section 705-65]*

4.85 This step allows the joined group to avoid double taxation of the profits of the joining entity that were undistributed at the joining time (other than those profits earned before the commencement of the dividend imputation system). In the absence of this adjustment, the group's allocable cost amount (excluding taxed retained earnings) would be spread across all the joining entity's assets, including those that represent the taxed profits of the entity. This would result in double taxation upon the disposal of those assets.

**Example 4.7**

On 1 July 1998, Head Co subscribed \$6 for 60% of the membership interests in X Co. On 1 July 2002, Head Co forms a consolidated group and acquires the remaining 40% of the membership interests in X Co for \$32. At that time, X Co has taxed retained profits of \$70, and one reset cost base asset with a cost base and market value of \$80.

In the absence of any adjustment, Head Co's allocable cost amount for X Co would be \$38, being the cost base of Head Co's membership interests in X Co (\$6 + \$32). The deemed purchase payment (and cost base) for the reset cost base asset brought into the group by X Co would be \$38. If this asset were subsequently sold for its market value (\$80), a capital gain of \$42 would be realised. The taxation of the capital gain would represent double taxation of the 60% of the \$70 retained profits of X Co that accrued to Head Co's continuously held membership interests.

The adjustment under this step would increase the group's allocable cost amount in relation to X Co by \$42 to \$80. This would become the deemed purchase payment for the reset cost base asset brought into the group by X Co.

**Step 4: Deduct pre-joining time distributions of profits that were earned before the membership interests were acquired or which recouped a loss**

4.86 The fourth step in determining a group's allocable cost amount for a joining entity is to subtract distributions to the head company (directly, or indirectly by distribution to an entity in which the head company has a direct or indirect membership interest) by the joining entity which arise out of *pre-acquisition profits*. Distributions out of pre-acquisition profits are those distributions that exceed profits that accrued to membership interests directly or indirectly held by the head company or distributions out of profits that recouped a loss that accrued to the head company's interests. [*Schedule 1, item 1, subsection 705-70(1)*]

4.87 In its application to a distribution of pre-acquisition profits, this step prevents the deemed payments for the joining entity's assets reflecting an amount paid for the membership interests in the entity that was later recovered through distributions. [*Schedule 1, item 1, subsections 705-70(2) and (4)*]

**Example 4.8**

On 29 September 2002, Head Co, the head company of a consolidated group, acquired 70% of the membership interests in F Co for \$420. At that time, F Co had assets with a market value of \$600, including undistributed taxed profits of \$100. On 30 September 2002, F Co paid a fully franked dividend of \$100 profits of which Head Co received \$70. Following the distribution, the assets of F Co have a market value of \$500.

On 1 October 2002, Head Co purchased the remaining 30% of membership interests in F Co for \$150 and F Co becomes a subsidiary member of Head Co's consolidated group. In the absence of any other adjustments, the group's allocable cost amount for F Co would be \$570 (reflecting the cost to Head Co of acquiring the membership interest in F Co). This would then be allocated to F Co's assets, which have a market value of only \$500. An immediate disposal of all of those assets would result in a capital loss of \$70, despite Head Co having suffered no economic loss.

An adjustment is required to reduce the allocable cost amount for F Co by the \$70 dividend paid by F Co to Head Co on 30 September 2002, which was a distribution of profits that were earned before Head Co acquired the membership interests in respect of which the dividend was paid.

4.88 In its application to a distribution out of profits that recouped a loss of the joining entity that accrued to the joined group, this step prevents the deemed payments for the joining entity's assets reflecting assets that are no longer held by the joining entity. [*Schedule 1, item 1, subsections 705-70(3) and (5)*]

**Example 4.9**

On 1 July 2002, Top Co, the head entity of a consolidated group, acquired 60% of the membership interests in Subco for \$60. At that time, Subco had assets with a market value of \$100. In the year ended 30 June 2003, Subco made a loss of \$30. In the year ended 30 June 2004, Subco made a profit of \$30. Subco distributed this profit as an unfranked dividend on 1 July 2004 and Top Co receives \$18 of the dividend.

On 2 July 2004, Top Co purchased the remaining 40% of the membership interests in Subco for \$28 (reflecting a market value for Subco's assets of \$70) and Subco became a subsidiary member of Top Co's consolidated group. Top Co's allocable cost amount for Subco is \$70, consisting of \$88 for the cost of membership interests (step 1 in working out the allocable cost amount) less \$18 for a dividend paid to Top Co out of profits that recouped a loss that accrued to membership interests continuously held by Top Co (step 4).

In the absence of the adjustment for distributions out of profits that recoup 'owned' losses, the Top Co's allocable cost amount for Subco would be \$88, which would reinstate Top Co's share of the loss in an unrealised form when treated as Top Co's cost of acquiring Subco's assets.

**Step 5: Deduct losses accruing to continuously held membership interests**

4.89 The fifth step in determining a group's allocable cost amount for a joining entity is to subtract the carry forward tax losses and net capital losses of the joining entity to the extent that those losses:

- accrued to membership interests that were directly or indirectly owned by the head company and were continuously held by the head company until the joining time; and
- the losses represented an outlay or loss of economic resources.

*[Schedule 1, item 1, section 705-75]*

4.90 Whether a loss accrued to a membership interest that was continuously held by the head company is determined in the same manner as determining whether undistributed profits accrued to such an interest. The amount of a loss that accrued to a membership interest is the amount that would be distributed to that membership interest as it accrued if the loss were a profit.

**Example 4.10**

Jayco, the head company of a consolidated group, acquired 90% of the membership interests in Kayco on 28 February 2003. In April 2003, Kayco disposed of an asset and realised a capital loss of \$30 on the

disposal. That \$30 became Kayco's carry forward net capital loss for the year ended 30 June 2003.

On 1 July 2004, Jayco purchased the remaining 10% of the membership interests in Kayco and Kayco became a subsidiary member of Jayco's consolidated group. In considering whether Kayco's net capital loss should be deducted in working out the allocable cost amount, it was determined that \$10 of the loss in value of the asset on which the capital loss was realised occurred after Jayco acquired a 90% stake in Kayco. Therefore, \$9 of the loss is required to be deducted (at step 5) in working out the allocable cost amount.

4.91 A loss is only deducted to the extent that it represents a loss of economic resources. For example, if part of a tax loss was attributable to an immediate income tax write-off of expenditure that increased the value of the entity's assets, the amount of loss to be deducted is the amount remaining after the expenditure that increased the value of the assets is disregarded.

#### **Example 4.11**

Farmco has a tax loss of \$100 for the year after claiming a deduction of \$80 for expenditure which added \$70 to the value of its farm (the other \$10 is consumed within the year). Due to a subsequent decline in value, the value the expenditure added to the farm at the joining time was \$60. The amount of the tax loss that represents a loss of economic resources is \$40 (\$100 – \$60).

4.92 The reference in section 705-75 to tax losses and net capital losses will be adjusted to include:

- any overall foreign loss in respect of a class of assessable foreign income (within the meaning of section 160AFD of the ITAA 1936);
- any amount that would have been included in the overall foreign loss in respect of a class of assessable income but which is not recognised because of the operation of section 23AH of the ITAA 1936, except to the extent the loss would have been recouped if recoupment income had not been exempted under that section; and
- any capital loss which has been disregarded because of subsections 23AH(8A) and (9A) of the ITAA 1936, except to the extent that the capital loss would have been recouped if the recouped capital gains had not been exempted under that section.

---

**Step 6: Deduct certain losses transferred to the head company of the joined group by the joining entity**

4.93 The sixth step in determining a joined group's allocable cost amount for a joining entity is to subtract an amount in relation to certain losses transferred to the head company of the joined group by the joining entity at the joining time. [*Schedule 1, item 1, section 705-85*]

4.94 This step relates to the remainder of joining entity's losses transferred to the head company of the joined group which were not deducted at step 5. In addition, this step only applies to those losses to the extent of any excess of the allocable cost amount worked out to the end of step 5, over the sum of the terminating values of the assets of the joining entity.

4.95 This adjustment reflects what would have happened if instead of the former owners of the joining entity selling their membership interests in the joining entity, the joining entity had sold its assets. The joining entity's net capital gain from the sale of the assets would have been offset against the carry forward loss. The adjustment has the effect that the consolidated group does *not* get the benefit of an increase in 'cost' for the assets (relative to their terminating values) to the extent of the remainder of the carried forward losses not deducted at step 5.

**Example 4.12**

Trader Co subscribed \$100 for all of the membership interests in new company Z Co. Z Co used the \$100 to acquire 2 assets for \$70 and \$30 respectively. Trader Co and Z Co do not form a consolidated group.

Subsequently, Z Co disposed of its second asset for \$0, realising a net capital loss of \$30 ( $\$0 - \$30$ ).

On 1 July 2004, Head Co, the head company of a consolidated group, acquires all of the membership interests in Z Co for \$120. At that time, Z Co's asset (which has a cost base of \$70) has a market value of \$120. Z Co also has the carry forward net capital loss of \$30 which is able to be transferred to Head Co for future utilisation.

In the absence of any adjustment, the allocable cost amount for Z Co would be \$120, which would mean that Head Co would make no gain on an immediate disposal of the asset brought into the group by Z Co. Head Co would also have the benefit of the carry forward net capital loss of \$30. This is an incorrect outcome because a net gain position of \$20 (i.e.  $\$120 - \$70 - \$30$ ) for Z Co has translated into a realised gain of \$20 to Trader Co and a loss of \$30 that Head Co can utilise against future gains.

To address this, Head Co's allocable cost amount for Z Co is reduced by the amount of the loss (\$30), so that an immediate disposal of the asset brought into the group by Z Co would result in a \$30 capital gain against which the loss could be offset.

#### When is a membership interest continuously held?

4.96 Steps 3 to 5 in the calculation of the allocable cost amount require that profits and losses of a joining entity be worked out for the period that each membership interest in the joining entity was continuously held. Generally this would be the period that:

- starts when the head company starts to hold directly or indirectly membership interests in the joining entity which the head company continues to hold until the joining time; and
- ends at the joining time.

*[Schedule 1, item 1, section 705-80]*

4.97 However, a membership interest will be taken not to have been held continuously if, before the joining time, the cost base or the reduced cost base of the membership interest was taken by a provision of the ITAA 1936 or the ITAA 1997 to be the market value at a particular time. Where this occurs the membership interest is taken not to have been held by the head company prior to the time the cost base was taken to be its market value.

#### **Example 4.13**

At 1 July 1997, Head Co owns 50% of the membership interests in each of L Co and M Co. On 1 July 1998, L Co acquires 60% of the membership interests in P Co. On 1 July 1999, L Co transfers its interest in P Co to M Co. There is no rollover relief available in relation to the disposal. On 1 July 2002, Head Co acquires the remaining membership interests in L Co and M Co, and chooses to form a consolidated group. On 1 July 2003, M Co acquires the remaining 40% of the membership interests in P Co which causes P Co to join the consolidated group.

Head Co first began to hold an indirect interest in P Co (the joining entity) on 1 July 1998. However, the continuity of holding in relation to this interest is broken when L Co transfers its interest in P Co to M Co without rollover. The period during which membership interest will be taken to have been held continuously will start on 1 July 1999 (i.e. when M Co first held membership interests in P Co which were then held continuously until the joining time).

4.98 Table 4.3 contains examples of provisions within the ITAA 1936 and the ITAA 1997 that set the cost base and reduced cost base of membership interest in an entity to market value at a particular time. If 2 or more of the provisions apply, the interest is taken to have been acquired at the latest of the times specified.

**Table 4.3: Certain deemed acquisitions under the CGT provisions**

<i>Provision</i>	<i>What the provision is about</i>
Section 160ZZS of the ITAA 1936 and Subdivision C of Division 20 of Part IIIA of the ITAA 1936.	Changes in majority underlying interests in pre-CGT assets.
Paragraph 160ZZOA(1)(e) of the ITAA 1936.	Companies ceasing to be related after application of section 160ZZO (on rollover for asset transfers between related companies).
Subsection 160M(12) of the ITAA 1936.	Becoming an Australian resident.
Subsection 104-175(8) of the ITAA 1997.	Company ceasing to be a member of a wholly-owned group after rollover.
Subsection 136-40(3) of the ITAA 1997.	Becoming an Australian resident.
Subsections 149-30(1) or 149-70(2) of the ITAA 1997.	When an asset stops being a pre-CGT asset.

Preservation of pre-CGT status of membership interests in a joining entity

4.99 The pre-CGT status of membership interests in a joining entity are an attribute of assets of the group being joined and not an attribute of assets of the joining entity. Therefore, preservation of this status, unlike the preservation of pre-CGT status of assets of a joining entity, is not an exception to the clean slate rule (discussed in Chapter 2). The method for preserving the pre-CGT status of membership interests is attributable to intra-group membership interests being disregarded (under the single entity rule) within a consolidated group and a group's cost for membership interests being *stored* in its cost for assets.

4.100 If any of the membership interests in a joining entity are pre-CGT assets, the pre-CGT status of those interests is preserved by attaching a pre-CGT factor to the assets of the joining entity at the joining time, other than those that are *current assets* in accordance with the accounting standards or statements of accounting concepts [*Schedule 1, item 1, section 705-90*]. The term current asset is defined in Accounting Standard AASB 1010 (Accounting for the revaluation of non-current assets) as meaning "in relation to an entity, cash or other assets of the entity that would in the ordinary course of operations of that entity be consumed or converted into cash within twelve months after the end of the last financial year of the entity".

4.101 This allows a proportion of the membership interests in an entity that leaves (not necessarily the joining entity referred to in this paragraph) a consolidated group to be treated as pre-CGT assets by reference to the pre-CGT factors of assets in the leaving entity (see paragraphs 4.178 to 4.183).

4.102 The pre-CGT factor that applies to each asset, that is not a *current asset*, is obtained by dividing the sum of the market values of the pre-CGT membership interests in the joining entity (except any employee shares) by the sum of the market values of all the assets of the joining entity at the joining time that are not current assets. However, if the amount calculated in this way would be more than one, the pre-CGT factor is one.

4.103 The pre-CGT factor only attaches to assets that existed at the joining time and is lost if the asset is disposed of directly (rather than indirectly by way of disposing of an entity which takes the asset with it). The factor is not attached to any replacement asset.

***What happens when a consolidated group is formed?***

4.104 Each entity that becomes a subsidiary member of a consolidated group at the time it is formed (the formation time) is treated in the same way, subject to certain modifications, as an entity joining an existing consolidated group.

4.105 In general, when a consolidated group is formed, no changes are made in relation to the assets of the head company of the group. Intra-group debt and intra-group membership interests held by the head company are exceptions. These are not recognised for income tax purposes after the group is formed. Another exception applies to certain pre-CGT assets where a group forms in the transitional period (see paragraphs 4.218 and 4.219).

4.106 The modifications to the case of a single entity joining a consolidated group are:

- order of application of deemed purchase of joining entities' assets (see paragraph 4.107);
- membership interests to which Subdivision 165-CC of the ITAA 1997 applies (see paragraphs 4.108 to 4.111);
- cost base adjustments where there have been certain rollovers before the formation time (see paragraphs 4.112 to 4.117);
- adjustments to cost bases of membership interests for value shifting and transfers of losses (see paragraphs 4.118 to 4.119);
- adjustments for excess distributions of profits (see paragraphs 4.120 and 4.121);
- allocation of allocable cost amount to membership interests in subsidiary entities with certain losses (see paragraphs 4.122 to 4.124); and
- determining a pre-CGT factor for assets of subsidiaries (see paragraphs 4.125 and 4.126).



*Order of application of deemed purchase of joining entities' assets*

4.107 Where a subsidiary member of the group (the first subsidiary) holds membership interests in another subsidiary member of the group (the second subsidiary), it is necessary to first apply the rules to the purchase of the assets of the first subsidiary. This will set a payment for the acquisition of those assets by the head company, including for the membership interests in the second subsidiary. The deemed payment for the acquisition of membership interests in the second subsidiary will then determine the cost base of those membership interests for the purposes of determining the joined group's allocable cost amount in relation to the second subsidiary.

**Example 4.14**

Head Co owns all the membership interests in T Co. T Co owns all the membership interests in X Co. On 1 July 2002, Head Co forms a consolidated group with the other companies.

First, work out Head Co's payments for the acquisition of T Co's assets according to the rules for an entity joining a consolidated group (paragraphs 4.32 to 4.95). T Co's assets will include the membership interests T Co holds in X Co.

Then work out Head Co's payments for X Co's assets according to the same rules. For this purpose, the cost base of the membership interests in X Co (step 1 in working out the allocable cost amount) is determined by Head Co's deemed payment for those membership interests, which forms part of Head Co's deemed payment for all of T Co's assets.

*Membership interests to which Subdivision 165-CC applies*

4.108 If any membership interests that are directly held in subsidiary entities by the head company are assets to which Subdivision 165-CC (about changes of ownership or control of a company that has an unrealised net loss) applies, a proportion of each asset at the formation time of the entity in which those membership interests are held will be assets to which Subdivision 165-CC applies.

4.109 The proportion of each asset to which Subdivision 165-CC applies is set by the formula:

$$\frac{\text{market value of all membership interests in the subsidiary member to which Subdivision 165-CC applies}}{\text{market value of all membership interests in the subsidiary member}}$$

4.110 The effect of Subdivision 165-CC is that the proportion of a capital loss or trading stock loss made in respect of the asset will be subject to the same business test.

4.111 The form of the application of the same business test to the head company of the consolidated group is under consideration.

*Cost base adjustments where there have been certain rollovers before the formation time*

4.112 In certain circumstances appropriate adjustments need to be made to the cost bases of membership interests in subsidiary members of the group before the formation time.

4.113 Cost base adjustments will need to be considered where all of the following conditions are met:

- before the formation time, there is a rollover under Subdivision 126-B of the ITAA 1997 or section 160ZZO of the ITAA 1936 in relation to a CGT asset;
- a member of the consolidated group was the recipient company, and the head company of the consolidated group was the originating company, in relation to the rollover;
- the recipient company was a 100% subsidiary of the originating company at the time of the rollover;
- CGT event J1 or section 160ZZOA of the ITAA 1936 (about a company ceasing to be a member of a wholly-owned group after a rollover) did not apply to the recipient company between the time of the rollover and the formation time; and
- the CGT asset that was the subject of the rollover is not a pre-CGT asset at the formation time.

4.114 If these conditions are met, the cost bases of the membership interests in the recipient company are adjusted for the purposes of determining the consolidated group’s allocable cost amount in relation to that company. The cost base of each membership interest is reduced (if the amount worked out for the purposes of this rule is positive) or increased (if the amount is negative) by the amount worked out as follows:

$$\frac{\text{market value of membership interest}}{\text{market value of all membership interests of members in the recipient company}} \times \left[ \begin{array}{l} \text{cost base to originating} \\ \text{company of any} \\ \text{consideration received} \\ \text{by it for CGT asset in} \\ \text{relation to CGT event} \end{array} - \text{cost base of CGT asset} \right]$$

4.115 If the value for membership interests resulting from the application of the formula is a negative value, that negative value should be used when working out the allocable cost amount of the entity in which the membership interests are held.

4.116 The components of the formula are such that, where the cost base of any consideration given to the originating company for the CGT asset in relation to the CGT event is equal to the cost base of the CGT asset at the time of the CGT event, no cost base adjustments will be required.

4.117 Membership interests that were pre-CGT assets at the time of the rollover but which have since ceased to be pre-CGT assets, because of either Division 149 of the ITAA 1997 or Subdivision 20 of Part IIIA of the ITAA 1936 are excluded.

*Adjustments to cost bases of membership interests for value shifting and transfers of losses*

4.118 Step 1 in the calculation of the allocable cost amount requires adjustment to the cost bases of membership interests in the joining entity, as those cost bases would have been adjusted for prior intra-group value shifting transactions or loss transfers for working out the gain or loss on a disposal of the membership interests. Also, an adjustment is required in step 1 to add back to the reduced cost base of membership interests in the joining entity any reduction to this cost base previously made under subsection 110-55(7) of the ITAA 1997.

4.119 To ensure that these adjustments do not have a cascading effect on formation, where membership interests are held in subsidiary members that have membership interests in other subsidiary members, the adjustments should be made prior to applying the “order of application of deemed purchase of joining entities’ assets” discussed in paragraph 4.103.

*Adjustments for excess distributions of profits*

4.120 A modification to step 4 of the allocable cost amount calculation is required on formation of a group to prevent duplication of reductions in the allocable cost amount for distributions that are effectively a return of the cost of acquiring membership interests. This duplication can occur if reductions are made separately for the distribution of the same profits through a chain of 2 or more entities.

4.121 The required modification is that if a reduction to the allocable cost amount for a subsidiary entity at the formation time is required because of step 4 and the cost bases of membership interests in the subsidiary have been reduced because of reductions in the allocable cost amounts for one or more other subsidiaries under step 4, the required reduction to the allocable cost amount is reduced by the sum of those reductions to the cost bases of membership interests. However, the required reduction at step 4 is not to be reduced below nil.

### Example 4.15

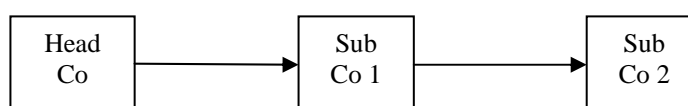

Suppose Sub Co 2 makes an *excess* distribution of profits (i.e. a distribution that would require an amount to be deducted at step 4 in working out the allocable cost amount for an entity joining a consolidated group – see paragraphs 4.86 to 4.88) to Sub Co 1 and Sub Co 1 does not make an excess distribution of profits to Head Co. Although the cost for Sub Co 1’s membership interests in Sub Co 2 would be reduced by the application of step 4 in working out the allocable cost amount, this will be negated because of the ‘top down’ approach in determining the deemed payments for assets (see paragraph 4.107) and Head Co’s cost for its membership interests in Sub Co 1 is not to be adjusted. Step 4 does not require modification to secure this correct outcome.

Suppose, alternatively, that Sub Co 2 does not make an excess distribution of profits to Sub Co 1 but Sub Co 1 does make an excess distribution of profits to Head Co. Step 4, without modification, will not reduce the cost for Sub Co 1’s membership interests in Sub Co 2 but will reduce Head Co’s cost for its membership interests in Sub Co 1. Step 4, unmodified, operates correctly in this situation.

The third excess distribution possibility with this group structure is where Sub Co 2 makes an excess distribution of profits to Sub Co 1 and Sub Co 1 makes an excess distribution of profits to Head Co. In this case, step 4 unmodified would reduce the cost for membership interests directly at both levels. This would result in a duplicated reduction in cost for membership interests as a result of the distribution of the same profits at both levels.

To prevent this duplication, it is necessary to modify the operation of step 4 in its application to group formation. In terms of the example, it is necessary to reduce the amount of the reduction at step 4 when working out Sub Co 1’s allocable cost amount for Sub Co 2 to the extent that a similar reduction made when working out Head Co’s allocable cost amount for Sub Co 1 is already reflected in reduced costs for membership interests in Sub Co 2.

#### *Allocation of allocable cost amount to membership interests in subsidiary entities with certain losses*

4.122 The rule for the allocation of the allocable cost amount to reset cost base assets is modified on formation where a reset cost base asset is a membership interest in a group entity and that group entity has an amount of losses that will be deducted under step 5 of the allocable cost amount calculation. For the purpose of allocating the allocable cost amount, the value to be used for that membership interest is its market value plus the amount of that membership interest’s pro-rata share of the losses.

4.123 The modification also applies where a membership interest carries an indirect interest in the losses of another subsidiary member that will be deducted at step 5 in working out the allocable cost amount for that subsidiary.

4.124 The purpose of the adjustment is to prevent a distortion in the allocation of the allocable cost amount. In the absence of this provision, the losses of a subsidiary member would reduce both:

- the amount of the allocable cost amount that is allocated to membership interests, which represent direct or indirect interests in the subsidiary member with the losses (the unintended effect); and
- the allocable cost amount for the subsidiary member with the losses (the intended effect of step 5 in working out the allocable cost amount).

*Determining a pre-CGT factor for assets of subsidiaries*

4.125 Where membership interests in a subsidiary member are pre-CGT assets, the pre-CGT status of those interests is preserved by attaching a pre-CGT factor to certain assets of the subsidiary (see paragraphs 4.99 to 4.103).

4.126 If, when a consolidated group is formed, subsidiary members of the group hold membership interests in another subsidiary member of the group, a pre-CGT factor must first be worked out for the assets of those members before any pre-CGT factor can be worked out for the assets of the other subsidiary member.

**Example 4.16**

Head Co owns all the membership interests in T Co. T Co owns all the membership interests in X Co. On 1 July 2002, Head Co forms a consolidated group with the other companies.

First, work out the pre-CGT factor for T Co's assets, including for the membership interests T Co holds in X Co.

Then work out the pre-CGT factor for X Co's assets. For this purpose, the number of pre-CGT membership interests in X Co is determined from the pre-CGT factor for those membership interests worked out in determining the pre-CGT factor for all of T Co's assets.

***What happens when a consolidated group joins an existing consolidated group?***

4.127 When an existing consolidated group (the joined group) acquires another existing consolidated group (the joining group) the entities in the joining group become subsidiary members of the joined group. The payment for the assets is worked out on the basis that, in accordance with

the single entity rule, the head company of the joining consolidated group is treated as a single entity joining a consolidated group. This allows the rules for the basic case of a single entity joining an existing consolidated group to apply as though the head company of the joining group were the only joining entity.

4.128 The cost of acquiring the assets of the joining group is determined using the same rules that apply in the basic case of a single entity joining an existing consolidated group subject to some adjustments. The adjustments are for where there are:

- employee shares in a subsidiary entity of the joining group (see paragraph 4.129); and
- over-depreciated assets (see paragraphs 4.130 and 4.131)

*Adjustment for employee shares in subsidiary entity of the joined group*

4.129 A modification is required to the general rules to ensure that the step 2 amount used in working out the allocable cost amount is increased by the sum of the market values of all membership interests in each entity that is taken to be part of the head company of the joining group (as a consequence of the single entity rule) that are held by persons other than members of the joined group. Certain interests (i.e. employee shares) may have been disregarded in determining whether an entity is a member of a consolidated group. As these outside membership interests represent a liability to the joined group, an increase in the allocable cost amount is required to reflect these liabilities to persons outside the group. The amount to be added under step 2 will be reduced where employee shares were issued after the joined group acquired membership interests in the joining consolidated group.

*Adjustments for over-depreciated assets*

4.130 Modifications are also required to the rules which restrict the amount that is treated as a payment for over-depreciated assets as discussed in paragraphs 4.54 to 4.63. The policy in relation to over-depreciated assets generally does not recognise the cost for those assets to the extent of the ongoing income tax deferral related to them. This policy is maintained where a consolidated group joins another consolidated group.

4.131 Modifications to the operation of the general rules are required to ensure that:

- an asset is only subject to the rules about over-depreciated assets where its over-depreciation has not been reversed between the time it became an asset of the joining group and when that group joins the joined group; and

- the rule in subsection 705-45(4) has no application as that rule relates to the case where a joining entity that left another group with an asset that was an over-depreciated asset in respect of which that group had chosen not to adopt its adjustable value as its terminating value.

***What happens when multiple entities linked through membership interests join an existing consolidated group?***

4.132 When a consolidated group acquires an entity that either alone or together with one or more existing members of the joined group owns all of the membership interests (other than disregarded employee share interests) in other entities (the linked entities), all of these linked entities will become members of the joined group at the joining time.

4.133 This case does not apply where the multiple entities that are linked through membership interests comprise a consolidated group, as the rules relating to a consolidated group joining an existing consolidated group (see paragraphs 4.127 to 4.131) will apply.

4.134 The following provides a simple example of linked entities.

**Example 4.17**

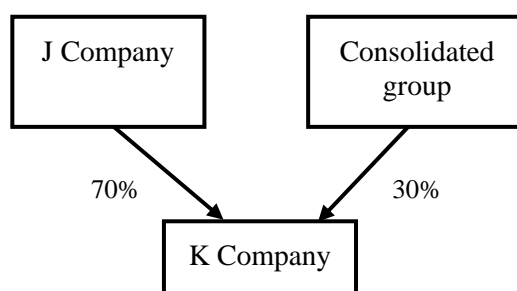

If the consolidated group acquires all of the membership interests in J Co then both J Co and K Co will become members of the consolidated group. J Co and K Co in this case are linked entities because they become members of a consolidated group as a result of an event that happens in relation to one of them.

4.135 The matters to be considered are:

- deemed payment for assets (see paragraphs 4.136 and 4.137); and
- pre-CGT factor for certain assets (see paragraph 4.138).

*Deemed payment for the assets worked out separately for each of the linked entities*

4.136 Each linked entity that becomes a member of the joined group at the joining time is treated in the same way as an entity joining an existing consolidated group. This means that the rules for the basic case of a single entity joining an existing consolidated group apply, except where specifically modified, in determining the payment for the assets of each of the linked entities.

Order of application of deemed purchase of linked entities' assets

4.137 Where a consolidated group (the joined group) and another entity (the first linked entity) jointly own another entity (the second linked entity) and the joined group acquires the first linked entity such that consequently the second linked entity also becomes a member of the group, it is necessary to first apply the rules deeming there to be an acquisition of the assets of the first linked entity. This will set a deemed payment for those assets, including the membership interests in the second linked entity. The deemed purchase payment for the membership interests in the second linked entity will then determine the cost base for those membership interests for the purpose of determining the joined group's allocable cost amount in relation to the second linked entity and so on.

**Example 4.18**

K Co is jointly owned by J Co and a member of a consolidated group (the original member). The consolidated group acquires all of the membership interests in J Co and consequently K Co also becomes a member of the consolidated group.

First, work out the deemed purchase payments for J Co's assets, including the membership interests J Co holds in K Co.

Then work out the deemed purchase payments for K Co's assets. For this purpose, part of the cost base of the membership interests in K Co is determined from the deemed purchase price payment for all of J Co's assets. The other part will be determined from the cost base of the membership interests held by the original member of the consolidated group in K Co.

*Determining the pre-CGT factor for certain assets of the joining linked entities*

4.138 As discussed in paragraphs 4.99 to 4.103, if any of the membership interests in a joining entity are pre-CGT assets, the pre-CGT status of those interests is preserved by attaching a pre-CGT factor to certain assets of the joining entity at the joining time. A modification is made to the general operation of this rule for retaining the pre-CGT status of certain assets by ensuring that the pre-CGT membership interests to be preserved by attaching a pre-CGT factor to underlying assets are pre-CGT membership interests held by members of the joined group only.



**Example 4.19**

Continuing on from Example 4.18, assume that the membership interests held by J Co and the original member of the consolidated group in K Co are both pre-CGT assets. Only the pre-CGT membership interests held by the original member of the consolidated group in K Co are taken into account in determining the pre-CGT factor to be attached to the applicable assets acquired from K Co.

This is achieved by first determining the pre-CGT factor for the applicable asset of J Co by taking into account the membership interests held by members of the joined group which are pre-CGT assets (in this example, the membership interests are not pre-CGT assets). Secondly, the pre-CGT factor for the applicable assets of K Co is determined by taking into account the membership interests held by members of the joined group which are pre-CGT assets. As the only relevant membership interests which are pre-CGT assets are those held by the original member of the consolidated group in K Co, then only the applicable assets acquired from K Co will have a pre-CGT factor attached to them.

***Rules for making subsequent corrections to the cost to a group of acquiring the assets of an entity***

4.139 These rules provide a method that minimises the compliance costs of making corrections to a consolidated group's cost for the assets of an entity that becomes a subsidiary member of the group. These rules apply:

- when an *error* is made in the calculation of the allocable cost amount (see paragraphs 4.141 to 4.144); and
- when the *settled amount of a liability is different* from the amount of the liability included in step 2 in the working out of the allocable cost amount (see paragraphs 4.145 to 4.150).

4.140 There may be *penalties* where the allocable cost amount is overstated (see paragraphs 4.151 and 4.152).

*What happens when an error is made in the calculation of the allocable cost amount?*

4.141 After the joining time an error may be discovered in the calculation of the allocable cost amount at the joining time and this error may require a number of years' assessments to be amended in order to adjust the payment amount for the assets of the joining entity.

4.142 Where it would be unreasonable, having regard to the amount of the error and the compliance costs involved in gathering the relevant information, to require the income tax assessments to be recalculated for those years, it is appropriate that an alternative method be available. The alternative method provides that a capital gain or loss of the amount of the error be included in the return of the head company in the income year in which the error is discovered.

4.143 Where the error is discovered at a time when it is not allowed to amend all the assessments necessary to correct the error, the capital gain or loss is reduced to the amount calculated under the following formula:

$$\text{capital gain/loss} = \text{error} \times \frac{\text{eligible reset cost base asset payment}}{\text{original reset cost base asset payment}}$$

where:

- **eligible reset cost base asset payment** is the amount of the payment for reset cost base assets of the joining entity that are held continuously from the joining time until the start of the earliest income year for which the Commissioner can still amend the assessment.
- **original reset cost base asset payment** is the amount of the payment for the reset cost base assets of the joining entity at the joining time.

4.144 The purpose of the formula is to prevent the notional amendment of assessments outside of the normal period for amending assessment.

**Example 4.20**

In year 1, a joining entity joins a consolidated group with the allocable cost amount allocated to assets as follows:

<u>Asset</u>	<u>Payment amount</u>
Trading stock	\$30
Depreciating asset	\$80
Capital asset A	\$40
Capital asset B	<u>\$60</u>
Allocable cost amount	\$210

In year 2, all of the trading stock and the depreciating asset are sold.

In year 7 (amendment of year 2 return is not allowed), an error in step 1 for determining the allocable cost amount is discovered to have overstated the allocable cost amount by \$30.

On the basis that it is unreasonable to take normal amendment action to correct the error, the single adjustment to correct the error is:

$$\begin{aligned} \text{capital gain} &= \text{error} \times \frac{\text{eligible reset cost base asset payment}}{\text{original reset cost base asset payment}} \\ &= 30 \times \frac{100}{210} \\ &= 14 \end{aligned}$$

---

Because all of the trading stock and the depreciating asset are sold in year 2, only capital assets A and B remain as eligible reset cost base assets.

*What happens when the settled amount of a liability is different from the amount of the liability included in step 2 in the working out of the allocable cost amount?*

4.145 Step 2 in the calculation of the allocable cost amount requires the liabilities of the joining entity that can, or must, be included in the entity's balance sheet at the joining time under accounting standards or statements of accounting concepts be added (see paragraphs 4.74 and 4.75).

4.146 However, when a liability of the joining entity is settled after the joining time, the settled amount of the liability may be different from the liability taken into account in the calculation of the allocable cost amount at the joining time.

4.147 Where it would be unreasonable, having regard to the amount of the difference and the compliance costs involved in gathering the information necessary to complete the amendments to correct for the difference, an alternative method is available. The alternative method provides that a capital gain or loss for the amount of the difference be included in the return of the head company in the income year in which the liability is settled, or if the difference becomes known sooner, the year in which the difference becomes known.

4.148 Where, the difference might not be known for many years after the joining time and it is not reasonable to reduce the capital gain/loss in the same way as discussed in paragraph 4.142, a consequential amendment to section 170 of the ITAA 1936 will allow the Commissioner a further period of 4 years after the time the liability is settled, or the difference becomes known, to correct the allocable cost amount and amend all assessments to take into account the adjusted payment amounts for assets.

4.149 When an entity leaves a consolidated group with a liability that was taken into account when working out the allocable cost amount of a joining entity, the amount of the liability at the leaving time will for these purposes be taken to be the settled amount of the liability.

4.150 Where some or all of the settled amount of a liability is deductible, the settled amount of the liability to be taken into account is reduced by the deduction multiplied by the general company tax rate. Also, where upon the settling of a liability an amount is included in assessable income, the settled amount of the liability is increased by the amount included in assessable income multiplied by the general company tax rate. These adjustments are necessary to align these provisions with the similar adjustment included in step 2 in the calculation of the allocable cost amount.

*Will penalties apply where a single adjustment is included?*

4.151 Where a single adjustment is included in assessable income, either to correct for an error in the allocable cost amount or where the settled amount of a liability is different from the amount of the liability included in step 2 of the allocable cost amount, a penalty may be imposed. The penalty will be similar to that imposed under the current penalty provisions but will only apply where the head company has not taken reasonable care when calculating the allocable cost amount. The shortfall amount will be limited to ensure that the penalty is imposed only where the payment amount has been taken into account in the calculation of a tax liability for an income year prior to the year in which either the error is discovered or the liability realised.

4.152 To achieve this purpose the shortfall amount for the imposition of the penalty will be calculated using the following formula:

$$\text{shortfall amount} = \text{capital gain} \left[ 1 - \frac{\text{adjusted reset cost base asset payment}}{\text{original reset cost base asset payment}} \right]$$

where:

- ***the adjusted reset cost base asset payment*** is the amount of the payment for all reset cost base assets that were held continuously from the joining time until the start of the income year in which the error was discovered or the liability settled less depreciation deductions claimed in respect of those assets; and
- ***the original reset cost base asset payment*** is the amount of the payment for the reset cost base assets of the joining entity at the joining time.

### **What happens when an entity leaves a consolidated group?**

4.153 Where an entity leaves a consolidated group there are implications for both the head entity and the entity that leaves. Entities may leave a consolidated group where:

- the group continues to exist (see paragraphs 4.154 to 4.193);  
or
- the group ceases to exist (see paragraphs 4.194 to 4.197).

---

***Group continues to exist***

4.154 When an entity (the leaving entity) leaves a consolidated group (the old group), there are consequences for the leaving entity and the head company of the old group. The time at which the leaving entity leaves the old group is called the leaving time.

***Treatment of head company***

4.155 The departure of an entity from a consolidated group has implications for the head entity of the group relating to the:

- deemed purchase of membership interests in the leaving entity (see paragraphs 4.156 to 4.183);
- deemed purchase of assets consisting of liabilities of the leaving entity owed to members of the group (see paragraph 4.184); and
- assessable income of head company in the year of exit (see paragraphs 4.185 to 4.188).

**Deemed purchase of membership interests in the leaving entity**

4.156 Immediately before the leaving time, the head company of the old group is deemed to have acquired the membership interests in the leaving entity that members of the group actually held at the time. The head company is taken to have paid for the membership interests of the leaving entity an amount that reflects the group's cost for the net assets of the leaving entity. [*Schedule 1, item 1, section 701-25*]

4.157 The deemed purchase of membership interests in the leaving entity does not apply to membership interests held by someone other than a member of the old group (i.e. an employee share).

4.158 Matters relating to the head company's deemed acquisition of the membership interests in the leaving entity are:

- the amount of the payment when a single entity leaves (see paragraphs 4.159 to 4.175);
  - more than one class of membership interests (see paragraphs 4.169 and 4.170);
  - head company's terminating value for an asset (see paragraph 4.171);
  - where there is a capital loss on disposal of membership interests (see paragraph 4.172);
  - treatment of goodwill (see paragraph 4.173); and

- cost base recoupments (see paragraphs 4.174 and 4.175);
- where a group of entities leave at the same time (see paragraphs 4.176 and 4.177); and
- pre-CGT status for membership interests (see paragraphs 4.178 to 4.183).

### **Amount of payment when a single entity leaves**

4.159 The amount treated as the payment for the deemed purchase of the membership interests in the leaving entity is determined by working out the *old group's allocable cost amount* for the leaving entity. *[Schedule 1, item 1, section 711-15]*

4.160 The old group's allocable cost amount for the leaving entity reflects the cost of the net assets that the leaving entity takes with it as well as certain adjustments. The allocable cost amount is determined in 5 steps. *[Schedule 1, item 1, section 711-20]*

4.161 The first step in determining the old group's allocable cost amount for a leaving entity is to add up the head company's terminating values (see paragraph 4.171) of all the assets that the head company holds at the leaving time because the leaving entity is taken to be part of the head company. *[Schedule 1, item 1, step 1 in the table in subsection 711-20(1)]*

4.162 The second step in determining the old group's allocable cost amount is to add the amount relating to any liabilities actually owed by members of the old group to the leaving entity at the leaving time. The amount is the market value of all the assets at that time. This element of the allocable cost amount is separately identified because, whilst an entity is a member of a consolidated group, liabilities it is owed by other members of the group are not recognised for income tax purposes. *[Schedule 1, item 1, step 2 in the table in subsection 711-20(1)]*

4.163 The third step in determining the old group's allocable cost amount is to subtract the amount of the leaving entity's liabilities at the leaving time that would be worked out under the basic case of a single entity joining an existing consolidated group as if those rules applied to the leaving entity at the leaving time in the same way as it applies to a joining entity at the joining time, subject to the following modifications:

- the reduction for intra-group liabilities (in subsection 705-60(4)) only applies in respect of a liability of the joining entity that is owed to a member of the group and that the amount of any such liability instead equals its market value;
- the adjustment for unrealised gains and losses (in subsection 705-60(5)) only applies in respect of a liability, or change in the amount of a liability, that is taken into account under generally accepted accounting principles sooner than occurs

for income tax and the amount that is to be taken into account under the step was equal to the payment that would be necessary to discharge the liability just before the leaving time without giving rise to a taxable gain nor an allowable deduction to the head company; and

- no adjustment is made to the amount included under the step for employee shares under subsection 705-60(7).

*[Schedule 1, item 1, step 3 in the table in subsection 711-20(1)]*

4.164 The fourth step in determining the old group's allocable cost amount is to subtract the amount determined under subsection 711-30 which applies where there are unrealised net losses and Subdivision 165-CC applies. This step ensures that the head company is not able to avoid the denial of certain losses by disposing of assets via an entity leaving a consolidated group rather than disposing of the assets directly.

*[Schedule 1, item 1, step 4 in the table in subsection 711-20(1)]*

4.165 Subsection 711-30 applies where:

- one or more of the assets of the leaving entity are assets to which Subdivision 165-CC applies; and
- the head entity were to dispose of such assets for their market values at the leaving time, the head entity would have made a loss that would have been denied or reduced because of section 165-115B or section 165-115BA,

the amount included at step 4 in determining the old group's allocable cost amount for the leaving entity is equal to the sum of the denied amounts. *[Schedule 1, item 1, subsections 711-30(1) and (2)]*

4.166 Any reduction in net asset values as a consequence of the application of subsection 711-30 will be taken into account as capital losses, deductions or trading stock losses for the purposes of the future application of section 165-115BB to the head company. Taking any reduction in net asset value into account as losses or deductions for the purposes of section 165-115BB has the effect of reducing the head entity's *residual unrealised net loss* so that the amount by which future losses or deductions of the head entity can be denied under this section is correspondingly reduced. *[Schedule 1, item 1, subsection 711-30(3)]*

4.167 If the resulting old group's allocable cost amount after steps 1 to 4 would be negative, it is instead taken to be nil, and the head company is taken to have made a capital gain equal to the negative amount *[Schedule 1, item 1, step 5 in the table in subsection 711-20(1)]*. The rules to provide for a capital gain are not included in the accompanying exposure draft of legislation.

4.168 In order to work out the deemed purchase payment for each membership interest in the leaving entity it is necessary to divide the old group's allocable cost amount for the leaving entity by the number of membership interests in the leaving entity (including any employee shares). *[Schedule 1, item 1, paragraph 711-15(c)]*

#### More than one class of membership interests in the leaving entity

4.169 If there is more than one class of membership interests in the leaving entity, membership interests of different classes may have different market values. In such instances, the payment for the deemed purchase of membership interests of different classes will also be proportional to the market values of the membership interests.

4.170 The payment for each membership interest is calculated by:

- first allocating the group's cost for the net assets of the leaving entity among the different classes in proportion to the aggregate of the market values of each class; and
- then dividing the cost for the net assets allocated to each class by the number of membership interests in the class.

*[Schedule 1, item 1, paragraph 711-15(b)]*

#### Head company's terminating value for an asset

4.171 The **head company's terminating value** for an asset is the amount that would need to be received for the asset to result in a tax-neutral disposal of the asset by the group. Consequently, there are generally no tax liability outcomes for a head company from the exit, as such, of an entity – as distinct from disposals of membership interests in an exited entity. Table 4.4 provides guidance on determining the head company's terminating value of assets. *[Schedule 1, item 1, section 711-25]*

**Table 4.4: Terminating values of assets of a head company**

<i>If the asset of the head company is...</i>	<i>The terminating value of the asset is...</i>
Trading stock that was on hand at the beginning of the income year in which the leaving time occurred.	The value at which it was taken into account by the head company at that time under Division 70 of the ITAA 1997.
Trading stock that was acquired by the head company during that income year.	The amount of the outgoing incurred by the head company in connection with the acquisition of the trading stock or, if there was no such outgoing, nil.



<i>If the asset of the head company is...</i>	<i>The terminating value of the asset is...</i>
A qualifying security (within the meaning of Division 16E of Part III of the ITAA 1936) that is not trading stock.	The amount of the consideration that the head company would need to receive if it were to dispose of the asset just before the leaving time in order for no amount to be included in, or deductible from, the head company's assessable income under section 159GS of the ITAA 1936.
A depreciating asset.	Its adjustable value at the leaving time.
Other CGT assets (not covered by above categories).	Its cost base just at the leaving time.
Other assets.	The amount that would have been its cost base at the leaving time if it were a CGT asset.

#### Where there is a capital loss on disposal of membership interests

4.172 If it is necessary to work out whether the head company makes a capital loss as a result of a CGT event that happens after the leaving time in relation to any of the membership interests, the amount of the deemed payment for the membership interest is instead worked out as if the terminating value of any CGT asset (that is not trading stock, a qualifying security or a depreciable asset) is instead equal to its reduced cost base at the leaving time. [*Schedule 1, item 1, subsection 711-20(3)*]

#### Treatment of goodwill

4.173 Goodwill will be an asset of a leaving entity where it can be demonstrated that goodwill is leaving the group or is lost to the group as a result of the leaving entity ceasing to be a member of the group. This could occur, for example, because the goodwill is linked to assets of the leaving entity, or because of the entity leaving, some synergy is lost to the group. [*Schedule 1, item 1, subsection 711-20(2)*]

#### Cost base recoupments

4.174 There may be an asset that is a 'right to recoupment' or 'right to input tax credit' that is recognised under accounting principles in the balance sheet of the leaving entity at the leaving time, and if the recoupment or the input tax credit were received before the leaving time, subsections 110-45(3), 110-55(6) and 110-45(3A) of the ITAA 1997 would apply to reduce the cost bases of an underlying asset. Where this occurs, the cost bases of the underlying asset will be reduced and allocated to the asset that is a right to recoupment or right to input tax credit. The terminating value of the asset is the amount of the right to recoupment or right to input tax credit included in the balance sheet under accounting principles.

4.175 Without this, the leaving entity would inappropriately make a capital gain when the amount is received, the asset right to recoupment or right to input tax credit having a terminating value of nil – see paragraphs 4.190 and 4.191.

#### **Where a group of entities leave at the same time**

4.176 Where, at the leaving time, the leaving entity holds membership interests in other subsidiary members of the consolidated group, then those other subsidiary members will also cease to be members of the group at the leaving time. In these situations, the deemed purchase payment for the membership interests in each of the leaving subsidiaries must be worked out on a ‘bottom-up’ basis. This ensures that the assets of an entity (the first entity) that are membership interests in another leaving member of the group are first given a deemed purchase payment, which will then be used to determine the terminating value of that asset in working out the deemed purchase payment for membership interests in the first entity. *[Schedule 1, item 1, section 711-35]*

#### **Example 4.21**

On 30 June 2003, M Co (the leaving entity) leaves a consolidated group (the old group). M Co, before the leaving time, owned shares in B Co and C Co. B Co owned shares in D Co and E Co. The companies were all members of the consolidated group.

The leaving entity and all those companies ceased to be members of the consolidated group at the leaving time.

In order to work out the deemed purchase of the membership interests in the leaving entities it is necessary to first work out the payment for the membership interests in Companies C, D and E.

Next, work out the deemed payment for the membership interests in B Co, taking into account the deemed payment just worked out for its assets consisting of shares in companies D and E.

Finally, work out the deemed payment for the membership interests in the leaving entity, taking into account the deemed payments worked out for the membership interests for companies B and C.

4.177 Consideration is being given to the rules required to prevent lost duplication where a group of entities leave at the same time.

#### **Pre-CGT status for membership interests**

4.178 Where, just before the leaving time, any of the assets held by the head company that the leaving entity takes with it had a pre-CGT factor (discussed in paragraphs 4.99 to 4.103), a number of the membership interests in the leaving entity held by members of the group will be treated as having been acquired before 20 September 1985. *[Schedule 1, item 1, section 711-40]*

4.179 The number of membership interests that will be treated in this way is determined by multiplying the leaving entity's pre-CGT proportion by the number of membership interests in the leaving entity held by members of the consolidated group. The result of this calculation is rounded down to the nearest whole number (if not already a whole number) or to zero if the result is more than zero but less than one. *[Schedule 1, item 1, subsection 711-40(4)]*

4.180 The leaving entity's pre-CGT proportion is calculated by dividing the aggregate of the market values of the pre-CGT factor components of the assets of the entity by the aggregate market value of the whole of its assets. For this purpose, the market value of the pre-CGT component of an asset is the market value of the asset multiplied by its pre-CGT factor. *[Schedule 1, item 1, subsection 711-40(5)]*

4.181 The number of membership interests in the leaving entity held by members of the group that are treated as having been acquired before 20 September 1985 has effect regardless of when the membership interests were actually acquired. *[Schedule 1, item 1, subsection 711-40(2)]*

4.182 If there are 2 or more classes of membership interests in the leaving entity, the rules discussed in paragraphs 4.179 and 4.180 operate separately in relation to each class as if the interests in that class were all of the interests in the leaving entity. *[Schedule 1, item 1, subsection 711-40(6)]*

4.183 If 2 or more entities cease to be subsidiary members of the old group at the same time then the rules discussed in paragraphs 4.179 and 4.180 apply to all membership interests that the head company is taken to acquire in the leaving entities and to all membership interests that the leaving entities are taken to acquire in the other leaving entities as if they were membership interests that the head company is taken to acquire in one leaving entity. *[Schedule 1, item 1, subsection 711-40(6)]*

#### Deemed purchase of assets consisting of liabilities of the leaving entity owed to members of the group

4.184 Liabilities owed by the leaving entity to members of the old group at the leaving time are taken to have been purchased by the head company at that time for a payment equal to the market value of the liability at the leaving time. This is necessary because, whilst an entity is a member of a consolidated group, debts it owes to members of the group are not recognised for income tax purposes. *[Schedule 1, item 1, section 701-30]*

#### Assessable income of the head company

4.185 There are generally no income tax consequences for the head company as a result of a subsidiary member leaving the group (as distinct from the disposal of membership interests in the leaving entity). There are specific rules for the trading stock of the leaving entity to achieve this (see paragraph 2.33).

4.186 An exception is that the market value of an asset right to recoupment recognised under accounting principles in the balance sheet of the leaving entity at the leaving time that would be included in the assessable income of the head company when the amount of recoupment is received. The change is that the amount is assessable income of the head company in the income year in which the entity leaves the group.

4.187 The exit clean slate rule, which is currently being reviewed (see paragraphs 2.35 to 2.41), will ensure that any recoupment received by the leaving entity of a tax deductible outgoing incurred by the head company will not be assessable income of the leaving entity. The receipt of the recoupment by the leaving entity will replace the asset right to recoupment recognised at the leaving time and any difference will give rise to a capital gain or loss.

4.188 Another exception relates to deferred primary production income. Division 385 of the ITAA 1997 allows certain primary production income received in one income year to be deferred or spread over a number of years. Where the primary production business is carried on by an entity that leaves a consolidated group and not all of the primary production income has been included in assessable income of the head company at the leaving time, the amount of unreturned income will be included in the head company's assessable income for the income year in which the leaving time occurs. This will result in subsection 385-163(1) applying with the result that a 'disentitling event' occurs for the purpose of Subdivision 385-H at the leaving time.

#### *Treatment of leaving entity*

4.189 The assets that the leaving entity takes with it:

- are deemed to be acquired for a payment (see paragraphs 4.190 to 4.192); and
- may include liabilities owed to it by members of the group (see paragraph 4.193).

#### Deemed purchase of assets

4.190 At the leaving time, the leaving entity is treated as having acquired the assets (including trading stock and depreciating assets) that the head company holds at that time because the leaving entity is treated as a part of the head company. This results in a transfer of the ownership of the assets for tax purposes from the head company to the leaving entity. *[Schedule 1, item 1, section 701-40]*

4.191 The leaving entity is taken to have paid an amount for the purchase of each asset equal to the head company's terminating value for the asset (see paragraph 4.163). *[Schedule 1, item 1, subsection 711-45(1)]*

### **Recalculation in order to work out amount of capital loss**

4.192 If it is necessary to work out whether the leaving entity makes a capital loss as a result of a CGT event that happens after the leaving time in relation to a CGT asset (that is not trading stock, a qualifying security or a depreciable asset), the amount of the deemed payment for the asset is instead equal to its reduced cost base at the leaving time. *[Schedule 1, item 1, subsection 711-45(2)]*

#### Assets consisting of liabilities owed by members of the group

4.193 Liabilities owed by members of the old group to the leaving entity at the leaving time are taken to have been acquired by the leaving entity at that time for a payment equal to the market value of the liability. Specific recognition of these liabilities at this time is necessary because, whilst an entity is a member of a consolidated group, liabilities it is owed by members of the group are not recognised for income tax purposes. *[Schedule 1, item 1, subsection 711-45(3)]*

#### ***Group ceases to exist***

4.194 A consolidated group will cease to exist where:

- all the membership interests in the head company are acquired by another consolidated group (see paragraphs 4.195 and 4.196); or
- the head company otherwise ceases to be eligible to continue to be a head company (see paragraph 4.197).

#### *Where the group joins another consolidated group*

4.195 A leaving entity may cease to be a member of an existing consolidated group because the head company of the existing consolidated group becomes a wholly-owned subsidiary of:

- the head company of another existing consolidated group (which will result from its acquisition by one or more members of that group); or
- a common Australian corporate tax entity. This can occur through a change in ownership of some or all of the membership interests in the head company or as a result of the existing owner of the head company becoming a common Australian corporate tax entity) that immediately forms a consolidated group.

4.196 In this event the relevant rules for the treatment of the assets of the consolidated group are those that apply when a consolidated group joins an existing consolidated group (discussed in paragraphs 4.127 to 4.131). The rules about leaving a consolidated group will not apply. *[Schedule 1, item 1, subsection 711-5(1)]*

*Where a head company ceases to be eligible to remain as head company (other than because it joins another consolidated group)*

4.197 Upon a change in the status of a head company that renders the head company ineligible to remain as the head company of a consolidated group, the head company ceases to be eligible to hold the assets of its subsidiary members in the capacity of the head company of a consolidated group. Where this occurs each of the subsidiary members of the group will be treated as leaving entities.

## **Application and transitional provisions**

4.198 The rules dealing with the treatment of assets on joining or leaving a consolidated group are part of the consolidation regime that commences from 1 July 2002.

4.199 The transitional rules are applicable to a consolidated group if:

- the consolidated group comes into existence during the period from 1 July 2002 to 30 June 2003 (the transitional period); and
- one or more of the subsidiary members of the group are 100% Australian subsidiaries of the head company of the group at all times from 30 June 2002 until the consolidated group comes into existence.

## **Head company may choose to replace the purchase payment for assets and retain the tax history of certain subsidiaries**

4.200 Where a consolidated group comes into existence in the transitional period, the head company may choose that the payment for each of the assets is the joining entities' terminating value for the asset (see paragraph 4.41). This choice provides an option for groups to consolidate during the transitional period without having to undertake market valuations of all of the assets of subsidiary members of the group, or undertake allocable cost amount calculations for subsidiary members.

4.201 The choice is only available in relation to entities that were 100% Australian subsidiaries of the head company of the group at all times from the end of 30 June 2002 until the time the consolidated group comes into existence. However, the head company is not obliged to make the choice in relation to all such entities.

4.202 Where the choice is made to use the joining entity's terminating value for the assets, the entry clean slate rule (see Chapter 2) will not apply in respect of that joining entity. Therefore, the tax history of the joining entity prior to its becoming a subsidiary member of the group will be taken to be the head company's tax history.

4.203 There are also other implications from making this choice discussed in paragraphs 4.204 to 4.213.

***Residual unrealised net losses of joining entities***

4.204 Where a subsidiary member of the group for which the choice was made to retain the terminating values of its assets had a 'residual unrealised net loss' at the group's formation time, the residual unrealised net loss effectively becomes a residual unrealised net loss of the head company at the changeover time. The head company is also taken to have owned, at the changeover time, the CGT assets that the subsidiary member owned at that time provided they were still owned by the subsidiary member at the joining time. This outcome is achieved by the head company retaining the tax history of the subsidiary member through the exclusion of the clean slate rule.

4.205 The form of the application of the SBT that is to be applied to the head company of the consolidated group is under consideration.

***Reduced cost base***

4.206 Where a CGT asset (that is not trading stock, a qualifying security or a depreciating asset) has a reduced cost base that is different from its cost base, both the cost base and the reduced cost base are the joining entity's terminating values of the asset.

4.207 If the joining entity had a reduced cost base that was less than its cost base for a CGT asset, the lesser of the 2 payment amounts for the asset will be the first element in the head company's reduced cost base for the asset, notwithstanding that subsection 110-55(2) provides that the first element of the reduced cost base is the same as the first element of the cost base.

***Substituted head company***

4.208 If, at the formation time, membership interests in a subsidiary entity (A) are held by another subsidiary entity (B) and the head company has made a choice to use B's terminating values for B's assets, B is taken to be the head company (the substituted head company) in respect of A in relation to the membership interests held by B at the formation time. The substituted head company should be used for the purposes of steps 3, 4 and 5 in the calculation of the allocable cost amount (see paragraphs 4.84 to 4.92).

***Unfrankable undistributed profits rule does not apply to transitional subsidiaries***

4.209 The requirement that undistributed profits be frankable does not apply when working out the allocable cost amount for a subsidiary member that was a 100% Australian subsidiary of the head company from 1 July 2002 until the formation time. For these subsidiary members the

amount to be added at step 3 of the allocable cost amount calculation is the whole of the profits available for distribution from the activities of the subsidiary up to formation time (see paragraphs 4.84 and 4.85).

4.210 However, any unfrankable profits at the joining time will be taken to be:

- a distribution of profits for the purposes of deducting distributions of profits that were earned before membership interests were acquired or which recouped a loss at step 4 in working out the allocable cost amount (paragraphs 4.86 to 4.88); and
- an unfranked dividend for the purpose of adjusting the payment amount for any over-depreciated assets (see paragraphs 4.54 to 4.63).

To prevent a duplicated deduction, a specific provision will prevent unfrankable profits being taken into account in relation to over-depreciated assets to the extent that those profits formed part of any amount deducted for distributions of profits.

***No operation of value shifting and loss transfer provisions to membership interests in subsidiaries covered by the choice***

4.211 Where the head company of a consolidated group makes the choice to retain the joining entity's terminating values for the cost of its assets, then any outstanding cost base adjustments for value shifting or loss transfers will not apply to membership interests in that subsidiary member in relation to events that happened before the consolidated group comes into existence.

4.212 The cost base adjustments do not need to be made because intra-group membership interests within a consolidated group are ignored for income tax purposes. This means, for example, that the potential for losses to be duplicated or created in relation to those membership interests no longer exists.

***Determining a pre-CGT factor for assets of subsidiaries***

4.213 The rules for determining a pre-CGT factor for the assets of a subsidiary member are unchanged where a head company chooses the subsidiary member's terminating values for its assets. For this purpose, limited valuations will be required (i.e. valuation of the subsidiary entity itself and valuation of the aggregate of the assets to which a pre-CGT factor is attached). See discussion in paragraphs 4.99 to 4.103.

***Head company may choose a different rule for certain doubtful debts***

4.214 The head entity may choose, in relation to an entity in respect of which it was entitled to choose that the payment for each of its assets is



---

the joining entity's terminating value for the assets (see paragraph 4.201) but did not do so, that:

- the deemed payments for debts owed to the entity not be reduced even though it is expected that the full amount of the debt will not be paid; and
- the entry clean slate rule (section 701-5) not apply in relation to the debts.

4.215 Making this choice prevents the operation of the rule in subsection 705-20(2), with the consequence that the head entity may be entitled to a deduction for a bad debt where any of the debts is not repaid in full. This outcome is considered appropriate where the debt is owed to an entity that was a wholly-owned subsidiary of the head entity at the commencement of the operation of the rules for consolidation (1 July 2002), remains so until the consolidated group is formed and the group is formed within the transitional period.

### **Head company may choose to work out terminating value of an over-depreciated asset in a special way**

4.216 In certain circumstances, a consolidated group may choose to add back the whole or part of the adjustment for over-depreciation (see paragraphs 4.54 to 4.63) when working out its deemed payment for membership interests in a leaving entity (paragraphs 4.156 to 4.175 but note particularly paragraph 4.171). The required circumstances are that the asset was brought into the group by an entity that was a wholly-owned subsidiary of the head entity from 1 July 2002 until the group's formation and that the group formed on or before 30 June 2003.

4.217 This choice will provide transitional relief for groups with over-depreciated assets by allowing them to use a higher value in relation to the over-depreciated assets in determining the deemed purchase payment for membership interests in a leaving entity.

### **Head company may choose to use formation time market values instead of terminating values for certain pre-CGT assets**

4.218 Where a consolidated group comes into existence in the transitional period, and the head company holds pre-CGT assets at the formation time, the head company may choose to use the market values of those assets at the formation time as the terminating value of those assets for the purpose of calculating the cost for membership interests when an entity leaves the group. The choice is not available in relation to assets acquired by the head company after 21 September 1999 where the acquisition was subject to CGT rollover under Subdivision 126-B of the ITAA 1997.

4.219 This choice allows a group with pre-CGT assets held directly by a head company to place itself in an equivalent position to a group which has transferred pre-CGT assets in a rollover from a head company to a subsidiary member. Without this, groups would seek to transfer those assets to subsidiaries under rollover prior to forming a consolidated group.

---

# Chapter 5

## *Transferring losses to a consolidated group*

---

### Outline of chapter

- 5.1 This chapter explains:
- which losses may be transferred to the head company of a consolidated group; and
  - the effects of transferring a loss.
- 5.2 Modifications to the general loss rules which will apply in determining whether a transferred loss can be used by a head company are explained in Chapter 6.
- 5.3 The rules that limit the amount of a transferred loss that may be used by the head company are discussed in Chapter 7. Concessions available to groups that form during the transitional period are discussed in Chapter 8.

### Context of reform

- 5.4 The scheme for consolidated groups is based on the principles recommended by *A Tax System Redesigned*. One of the principles is that a company or trust entering a consolidated group should be able to bring its losses into the group.
- 5.5 The rules that provide for this are designed to ensure that the use of a joining entity's losses by the group approximates the rate at which they would have been used had the entity not joined the group. *A Tax System Redesigned* identified a large store of unused losses in the taxation system. Allowing losses to be automatically transferred to a group and used against group income without restriction would be too costly to the revenue.
- 5.6 Two main sets of rules govern losses and consolidated groups. First, the amount of losses that can be transferred to a consolidated group is restricted by ensuring that entities seeking to transfer losses to a consolidated group pass, at the transfer time, modified versions of the current tests for deducting or applying losses.
- 5.7 Second, the rate at which transferred losses can be used by the group is restricted. The method by which this is achieved departs from

that recommended by *A Tax System Redesigned*. The new method was developed in consultation with interested taxpayers and their advisers and is discussed in Chapter 7.

5.8 The provisions allowing the transfer (and use) of losses are *not* designed to facilitate the earlier or greater use of those losses. Rather, they ensure that the tax system does not stand in the way of commercial group restructures, impediments to which will be removed by the introduction of the consolidation regime. For the purposes of that efficiency objective, and as proposed by *A Tax System Redesigned*, the consolidation regime reflects changes to the loss usage tests. The changes are in recognition of the practical difficulties of applying those tests to consolidated groups.

## **Summary of new law**

### **Transferring losses to a consolidated group**

5.9 Each time an entity becomes a member of a consolidated group (whether as head company or a subsidiary) its unused carry forward losses are tested to determine whether they can be transferred to the group. *[Schedule 1, item 1, Subdivision 707-A]*

5.10 Broadly, a loss can only be transferred to the head company of a consolidated group if the loss could have been used outside the group by the entity seeking to transfer it (called the 'joining entity'). That is, the loss can be transferred if the joining entity could have deducted or applied the loss in the period immediately before transfer assuming it had sufficient income or gains of the relevant kind. Losses are tested for this purpose at the time the joining entity becomes a member of a group (called the 'joining time').

5.11 Basically, the joining entity applies the general rules for deducting or applying prior year losses as though the 12 months prior to the entity joining the group were the loss claim year. This will generally involve ascertaining whether, for the period since the loss was incurred up until the joining time, the joining entity has maintained substantially the same ownership or the same business. These ownership and business tests are modified to ensure they work appropriately as transfer tests.

### **The effects of transfer**

5.12 A transferred loss is taken to have been made by the head company to which it is transferred. This means the head company may either use the loss in working out its taxable income or transfer it to another group of which it becomes a subsidiary member. *[Schedule 1, item 1, subsections 707-105(1) and 110(1)]*

5.13 A loss transferred by a subsidiary member is no longer available for use by it, even if it subsequently leaves the group. The single entity

rule means the loss is not available for use by the subsidiary while it is a member of the group – the loss may only be used by the head company. The exit clean slate rule prevents the subsidiary using the loss after it leaves the group. These rules are discussed in Chapter 2.

5.14 Losses that do not satisfy the transfer tests are effectively cancelled in that they may not be used by any entity. [*Schedule 1, item 1, subsection 707-105(2)*]

5.15 A head company can choose to cancel the transfer of a loss. [*Schedule 1, item 1, section 707-145*]

## Comparison of key features of new law and current law

<i>New law</i>	<i>Current law</i>
All entities that can be members of a consolidated group (i.e. most companies and trusts) may transfer losses to the group.	Only companies may transfer losses to members of the same wholly-owned group. There is no provision for the transfer of losses by or to a trust.
All loss types (i.e. tax losses, net capital losses and foreign losses) may be transferred, provided they satisfy the transfer tests.	Only tax losses and net capital losses may be transferred. There is no provision for the transfer of foreign losses.
All of an entity's losses are tested when the entity joins a consolidated group. Those that pass are transferred to the group for possible later use by the group. Those that do not are effectively cancelled.	Losses may be transferred for use in a particular income year. But only to the extent the transferee has sufficient income, in that income year, against which the loss can be offset.
The head company can choose to cancel the transfer of a loss.	Losses are transferred by agreement between the transferor and transferee. There is therefore no provision for cancellation of a transfer.
Losses made by a joining entity <i>before</i> it became a member of the group may be transferred to the group, provided they satisfy the transfer tests.	Losses may only be transferred if the transferor and transferee were both members of the same wholly-owned group from when the loss was made until the time of transfer.

## Detailed explanation of new law

### Which losses can be transferred to a consolidated group?

5.16 The following losses may be transferred to a consolidated group:

- tax losses (including film losses);
- net capital losses; and
- foreign losses.

*[Schedule 1, item 1, subsection 707-115(1) and the definition of 'sort of a loss' in subsection 701-1(4)]*

5.17 These are losses that have been realised by the joining entity before the joining time. The treatment of capital losses that are unrealised at the joining time, and of debts that are outstanding at the joining time but written-off as bad after that time, is being developed.

5.18 Two broad categories of losses may be transferred:

- those that have been generated by the joining entity; and
- those that have previously been transferred to the joining entity.

5.19 This reflects the fact that an individual entity may join a consolidated group or, alternatively, the head company of one consolidated group may become a subsidiary member of another group. A head company joining another group may have both loss types – those generated by the group and those transferred into the group.

5.20 If the joining entity is also the head company of the group the losses it generated as a single entity are transferred to itself in its capacity as head company.

5.21 There are generally 3 steps to be followed each time an entity seeks to transfer losses to the head company of a consolidated group:

- step 1 – the entity works out its taxable income (or loss) for the period up to the time it joins the group;
- step 2 – the entity identifies the amount of its unused carry forward losses as at the joining time; and
- step 3 – the entity determines whether those losses satisfy the modified tests for using them.

***Step 1: Work out taxable income up to consolidation***

5.22 Where an entity joins a group as a subsidiary member part way through the entity's income year, it must work out its taxable income up to the joining time. *[Schedule 1, item 1, sections 701-1 and 701-45]*

5.23 The pre-joining taxable income is worked out in the normal manner, including deducting or applying carry forward losses from previous income years. A loss worked out for this pre-consolidation period is also available for transfer. This is discussed in paragraphs 5.90 to 5.99.

***Step 2: Work out carry forward losses that may be transferred***

5.24 An entity may only transfer carry forward losses that have not previously been used or otherwise reduced (e.g. under the debt forgiveness rules). Therefore:

- losses deducted or applied in working out taxable (or exempt) income up to the joining time are not available for transfer; and
- any losses that result from ‘ruling off’ at the joining time are available for transfer.

*[Schedule 1, item 1, paragraphs 707-115(1)(b) and 707-120(1)(b)]*

***Step 3: Work out which carry forward losses satisfy the use tests***

5.25 Only unused carry forward losses that, at the joining time, also satisfy the tests for utilising them may be transferred. *[Schedule 1, item 1, section 707-120]*

5.26 Broadly, an entity *utilises* a loss if it takes it into account in working out its taxable income. Specifically, if it:

- deducts a tax loss from assessable or exempt income;
- applies a net capital loss in reducing capital gains; or
- takes into account an overall foreign loss in respect of a class of assessable foreign income in reducing that income.

*[Schedule 1, item 1, subsection 707-110(2)]*

5.27 In this explanatory material, to ‘use’ a loss and to ‘utilise’ a loss mean the same thing.

**How are the tests applied for transferring losses to a group?**

5.28 The normal loss recoupment tests apply as though the joining entity had sought to use the loss in an income year that ended immediately after it joined the group.

***Assumptions to be used in applying the transfer tests***

5.29 Because those tests are normally only triggered when a loss is actually claimed, some assumptions need to be made to facilitate their use as loss transfer tests. The tests are applied to an unused carry forward loss as though:

- the entity had sought to claim the loss for an income year called the ‘trial year’ (the trial year generally starts 12 months

before, and ends immediately *after*, the entity joined the group);

- the entity has sufficient income of the relevant type against which its losses may be offset;
- the entity had not joined the group:
  - since a subsidiary entity cannot use its own losses after joining a consolidated group, the transfer tests (which test whether the joining entity could have used the losses) must pretend the entity had not joined the group; and
- the entity was a wholly-owned subsidiary of the head company if it joined as a subsidiary member:
  - this clarifies that the previous assumption does not alter the ownership structure of a subsidiary member (which means that changes in its ownership as part of the consolidation process are taken into account in determining whether the loss can be transferred).

*[Schedule 1, item 1, subsection 707-120(1)]*

5.30 The transfer tests may also be applied to losses generated in the income year of consolidation as a result of working out a final taxable income under step 1. That is, the usual rule that losses may only be used if they were incurred in a prior year is overridden so that the entry tests can be applied to step 1 losses. *[Schedule 1, item 1, subsection 707-120(4)]*

5.31 The assumptions are supplemented by some modifications to the ownership and business tests to ensure they work appropriately as transfer tests.

### ***Distinguishing between transfer and recoupment tests***

5.32 Because the tests work slightly differently when applied to determine whether a loss can enter a consolidated group, it is important to distinguish their use as entry or transfer tests from their normal application in determining whether a loss can be used (i.e. as recoupment tests).

5.33 In particular, the transfer process must be distinguished from the step 1 process of working out taxable income up to the joining time. In working out its taxable income up to the joining time, an entity may have used the relevant tests to deduct or apply losses. That occurs first. Transfer tests then apply for the purpose of determining whether any unused losses can be transferred to the head company.



5.34 However, events such as ownership changes that have occurred from the time the loss was incurred until immediately after the joining time may be relevant to both processes.

5.35 The application of the ownership and business tests as transfer tests must also be distinguished from their subsequent use by the head company as recoupment tests when seeking to use transferred losses.

### **How do the loss recoupment tests work as transfer tests?**

5.36 The entities and the tests relevant to each of them are listed in Appendix A (at the end of this chapter). The tests can broadly be categorised as follows:

- continuity of ownership;
- control;
- same business; and
- pattern of distributions.

5.37 The way in which each of them works as a transfer test is discussed in paragraphs 5.39 to 5.87. All of them are applied on the basis of the assumptions discussed in paragraphs 5.29 to 5.31.

5.38 The company tests for revenue and net capital losses are contained in Part 3-5 of the ITAA 1997. The company tests for foreign losses are those contained in sections 80A and 80DA of the ITAA 1936. The trust tests for revenue and foreign losses are contained in Schedule 2F to the ITAA 1936.

#### ***Transfer test – continuity of ownership***

5.39 The COT applies to companies and the 50% stake test applies to trusts.

5.40 Broadly, a company satisfies the COT if, from the start of the income year in which it made the loss until the end of the income year in which it claims the loss, the same individuals have, directly or indirectly (through the continuous holding of the same shares or interests):

- control of more than 50% of the voting power in the company;
- rights to more than 50% of the company's dividends; and
- rights to more than 50% of the company's capital distributions.

5.41 Corporate limited partnerships that are treated as companies because of section 94J of the ITAA 1936 also apply these tests, though they are not required to test maintenance of voting power.

5.42 The 50% stake test for trusts operates in a broadly similar manner, though trusts are also not required to examine voting power.

5.43 If the test is passed, the loss may generally be used and therefore transferred. However, if the entity is a company, it must also satisfy the control test. Further, if the entity is a non-fixed trust, it must also pass the pattern of distributions test (if relevant) and a control test.

*Testing ownership over a period*

5.44 Most companies and trusts to which the ownership test is relevant are required to test ownership continuously from the commencement of the income year in which the loss was incurred until the end of the income year in which it is sought to be deducted or applied (referred to as the ‘ownership test period’ or ‘test period’).

5.45 Because the trial year ends immediately *after* joining time, the relevant test periods for transfer purposes also end immediately after joining time. Therefore, a joining entity that would normally be required to test continuously must test its ownership from the commencement of the income year in which the loss was incurred until immediately after joining time.

5.46 The test has deliberately been extended until after the joining time to ensure that ownership changes that occur as part of a consolidation event are taken into account.

5.47 While the trial year ensures that the ownership test period ends immediately after joining time, it does not affect the commencement of the ownership test period. This period continues to start at the start of the loss year. This means it may start before or after the start of the trial year.

**Example 5.1**

Subco joins a consolidated group on 1 December 2004. It incurs a loss during the period 1 July 2004 to the joining time. The trial year is from 1 December 2003 to 1 December 2004. However, ownership is tested during the period from the commencement of the loss year to just after the joining time.

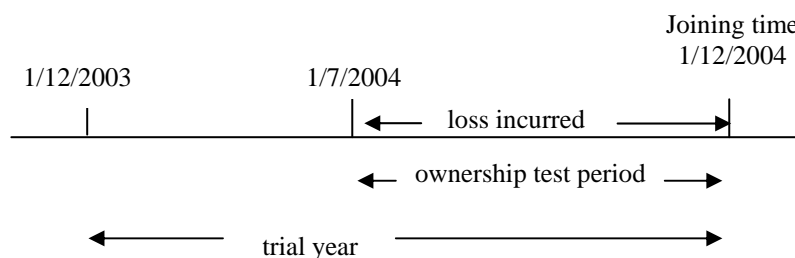

5.48 However, listed public companies and their 100% subsidiaries are only required to test ownership each time there is an abnormal trading in their shares and at the end of an income year (including the income year in which the loss is claimed).

5.49 An entity required to test ownership at the end of the income year will be required to test immediately after joining to see whether losses may be transferred. Again, any changes in ownership that result in the entity joining a consolidated group will be taken into account.

*Testing ownership where the loss has been previously transferred*

5.50 Broadly, a head company seeking to transfer a previously transferred loss need only test its ownership from the time the loss was first transferred to it. However, there is a further modification of the ownership test if the loss is a COT loss transferred to it by another company. These modifications are discussed in Chapter 6.

***Transfer test – control***

5.51 There are 2 control tests:

- that which applies to companies – it is failed if a person starts to control the entity’s voting power for the purpose of gaining a benefit or advantage in relation to the application of the Tax Act; and
- that which applies to non-fixed trusts – it is failed if, at any time during the test period, a group commences to control the trust (e.g. so it can obtain beneficial enjoyment of the capital or income of the trust).

5.52 Again the tests are applied as though the test period ended immediately after the joining time. It continues to start from the beginning of the loss year. Therefore, the purpose of the group’s acquisition of a company may be relevant in determining whether the company passes the control test and so can transfer losses.

***Transfer test – same business***

5.53 A company that fails the ownership or control tests, may nonetheless use (and therefore transfer) losses if it passes a same business test.

5.54 When used as a recoupment test, the same business test is basically passed if the business a company carries on during the income year in which it seeks to use the loss is the same as the one it carried on immediately before the ownership or control changed.

5.55 However, when used as a transfer test, the same business test is modified in 2 ways. First, by modifying the periods during which the same business must be carried on. This is discussed in paragraphs 5.57 to 5.73. Second, by applying an additional test if the loss was previously transferred because the same business test was passed. This is discussed in paragraphs 5.74 to 5.82.

5.56 In applying the same business test to the head company of a consolidated group, the business of the whole group is examined. This occurs whether the test is applied as a transfer test because one group is being merged with another or as a recoupment test when the head company seeks to use any of its losses.

*Same business test – modifying the periods during which it applies*

5.57 The same business test is modified so that there is a period of sufficient length to which it can be applied, given that the change in ownership and the joining may coincide. This is achieved by ensuring that, on transfer, one of the periods during which the joining entity's business is tested is the *trial year*. This is basically the 12 months before the joining time. [*Schedule 1, item 1, subsection 707-120(2)*]

5.58 However, the period will be less than 12 months if the joining entity did not exist for the whole of the 12 months prior to the joining time. In that case, the trial year only extends back to when the entity came into existence. The trial year may also be less than 12 months where the joining entity had previously been a subsidiary member of another consolidated group. In that case, the trial year does not go back any further than the time it last ceased to be a member of a consolidated group.

5.59 Also, in applying the same business test as a transfer test, the test period effectively ends immediately *before* the joining time. This is achieved by assuming that the business carried on by the joining entity at and just after the joining time is the same as the business it carried on just before the joining time. It also means that, when a group forms, a head company seeking to transfer its own losses to itself is, at and just after joining, still taken to be carrying on its own business and not that of the group. [*Schedule 1, item 1, subsection 707-120(3)*]

5.60 Additional modifications are made to the test periods for losses made for an income year starting after 30 June 1999. These are discussed in paragraphs 5.61 to 5.73.

*Same business test – companies*

5.61 As stated in paragraph 5.60, the test to be applied depends on the income year in which the loss was made.

**Table 5.1: Same business transfer tests for companies**

<i>Item no.</i>	<i>In these circumstances...</i>	<i>Test the joining entity's business at these points...</i>
1	The loss was made by the joining entity for an income year starting <i>after</i> 30 June 1999.	<ul style="list-style-type: none"> <li>• just before the end of the income year in which the loss was made;</li> <li>• the income year in which the joining entity first fails the ownership or control tests; and</li> <li>• the trial year.</li> </ul>
2	The loss was made by the joining entity for an income year starting <i>before</i> 1 July 1999.	<ul style="list-style-type: none"> <li>• just before the ownership or control tests were first failed; and</li> <li>• the trial year.</li> </ul>

*[Schedule 1, item 1, subsections 707-125(1) to (3) and subsection 707-120(1)]*

5.62 A loss made by the joining entity means either a loss that was actually made by the joining entity or one it is taken to have made as a result of being transferred to it previously (i.e. when it was a head company).

5.63 Therefore, the test in item 1 in Table 5.1 will also apply to a loss that has been the subject of one or more previous transfers for whatever reason. However, if the loss was previously transferred as a result of the same business test having been passed (called an 'SBT loss'), there is an additional test that must be applied. This is discussed in paragraphs 5.74 to 5.82.

5.64 A previously transferred loss will always be covered by item 1 in Table 5.1 because transferred losses are taken to have been made by the head company in the income year of transfer. Given that the consolidation regime does not commence until 1 July 2002, this will always be an income year starting after 30 June 1999.

5.65 The test points of the same business transfer tests that refer to a failure of the ownership or control tests necessarily refer to a failure that occurs *after* the commencement of the income year in which the loss was made. That is, these test points are linked to a failure of the ownership or control tests during the ownership test period.

5.66 The same business transfer test for losses made in an income year that starts after 30 June 1999 is stricter than the normal same business recoupment test. It is stricter because it tests at an additional point, namely just before the end of the income year in which the loss was made, and because it tests the whole of the income year in which the ownership or control tests are failed. This assists in giving the test integrity when used as a transfer test. Integrity is required because of the possibility that some or all of the test points will overlap or coincide.

5.67 Further integrity is built in by the concept of a ‘trial year’, which generally ensures that the business is tested for a minimum 12 month period. The trial year test point applies regardless of when the loss was made.

5.68 The acquisition of an entity may result in both the first change in ownership and entry of the entity into the group. In the absence of a 12 month test period, losses could be transferred and the same business test would be ineffective.

### Example 5.2

The joining entity makes a loss for the 2002-2003 income year which ended on 30 June 2003. It joins a consolidated group on 2 July 2003. On joining, it fails the ownership test.

If the existing same business test for recoupment of losses applied, the joining entity would only need to carry on the same business:

- immediately before 2 July 2003 (as that is when the change in ownership occurred); and
- for the 2 days from commencement of the 2003 income year (as, in the absence of a ‘trial year’ rule, that would effectively be the loss claim year).

Instead, the proposed 3 point test applies. That means the joining entity must carry on the same business for the whole of the 12 months before the joining time (i.e. from 2 July 2002 to the joining time).

5.69 The following examples show the 3 possibilities for losses made in an income year starting after 30 June 1999, depending on the extent to which the testing points overlap.

### Example 5.3: The test points are 3 separate periods

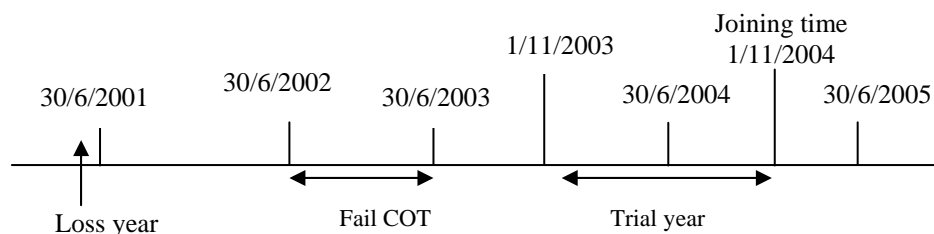

The joining entity must compare its business at 3 points:

- just before the end of the 2000-2001 income year (the loss year);

- the whole of the 2002-2003 income year (the year COT is failed); and
- 1 November 2003 to 1 November 2004 (the trial year).

**Example 5.4: The test points are 2 separate periods**



The joining entity must compare its business at 2 points:

- just before the end of the 2000-2001 income year (the loss year); and
- the whole of the 2004-2005 income year (the year the COT is failed and the trial year overlap).

**Example 5.5: All 3 test points overlap**

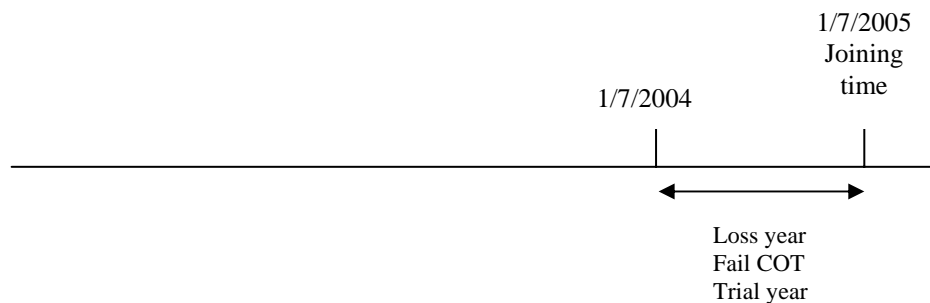

The entity must compare its business just before the end of the 2004-2005 income year (the loss year) with that carried on during the whole of the 2004-2005 income year (the trial year).

5.70 The requirement that a minimum 12 month period be tested may result in the joining entity’s business being tested for a period prior to the commencement of the income year in which the loss was made. That is, before the commencement of the ownership test period.

**Example 5.6**

An entity joins a consolidated group on 1 November 2004. It makes a loss for the period 1 July 2004 to the joining time. On joining, it fails the ownership test.

Applying the 3 point test, the joining entity must carry on the same business for the 12 months before the joining time (i.e. from 1 November 2003 to the joining time).

*Same business test – listed public companies (and their 100% subsidiaries)*

5.71 Tests similar to those set out in Table 5.1 also apply to listed public companies and their 100% subsidiaries.

5.72 However, when seeking to claim a loss, those entities are only required to test their ownership each time there is abnormal trading in their shares and at the end of each income year, including the year in which the loss is claimed.

5.73 These special testing rules are contained in Division 166 of the ITAA 1997. They apply to listed public companies and their subsidiaries, unless those companies choose that the general company rules in Division 165 apply. But there is no choice as to which set of rules apply as a transfer test. The rules in Division 166 apply (as modified by Table 5.2) if the company had used Division 166 in working out its taxable income up to the joining time.

**Table 5.2: Same business transfer tests for listed public companies and their 100% subsidiaries**

<i>Item no.</i>	<i>In these circumstances...</i>	<i>Test the joining entity's business at these points...</i>
1	The loss was made by the joining entity for an income year starting <i>after</i> 30 June 1999.	<ul style="list-style-type: none"> <li>• just before the end of the income year in which the loss was made; and</li> <li>• the income year in which the joining entity first finds there is no substantial continuity of ownership as a result of testing at the prescribed times; and</li> <li>• the trial year.</li> </ul>
2	The loss was made by the joining entity for an income year starting <i>before</i> 1 July 1999.	<ul style="list-style-type: none"> <li>• just before the joining entity first finds there is no substantial continuity of ownership as a result of testing at the prescribed times; and</li> <li>• the trial year.</li> </ul>



[Schedule 1, item 1, subsections 707-125(1) and (4) and 707-120(1)]

***Transfer test – previously transferred SBT losses***

5.74 A loss that has been transferred because the joining entity satisfied a same business test is called an SBT loss. These losses may only be transferred again if they pass an additional test.

5.75 Because the additional test only applies to the second or subsequent transfer of a loss, it will only apply to a head company that seeks to transfer an SBT loss on becoming a subsidiary member of another group. (Losses may only be transferred to a head company, so a head company is the only one that can transfer them again.)

5.76 Under the additional test, an SBT loss may only be transferred again if the entity transferring the loss carried on the same business at these times:

- just before the end of the income year in which the loss was previously transferred to it (this is also the income year in which the loss was taken to have been made); and
- during the trial year.

[Schedule 1, item 1, section 707-135]

5.77 This test is additional in that it is only applied *after* the usual (ownership and same business) transfer tests have been applied, and then only if one of those tests have been passed. (If the usual tests are failed the loss is effectively cancelled and the provision imposing this test can therefore not apply.)

5.78 If the additional test is passed, the loss will be transferred. If it is failed, the loss will be cancelled.

*Comparing the additional business test to the usual one*

5.79 The usual same business test only applies on transfer if the ownership or control tests are failed. However, the additional test applies even if the ownership or control tests have been passed.

5.80 For that reason, the additional test is contained entirely within the consolidation rules. It does not rest upon the normal deduction rules, or rely upon their triggers as do, for example, the same business transfer tests set out in Tables 5.1 and 5.2.

*Why is there an additional test for transferring SBT losses?*

5.81 A transferred loss is taken to be made by the head company to which it is transferred in the income year in which the transfer occurs. This effectively erases the previous failure of the ownership test if the loss is an SBT loss. Therefore, there may be no failure of the ownership test

when the loss is sought to be transferred subsequently to the head company of another group. For example, the second group may acquire the first group simply by increasing its ownership percentage in the head company of the first group from 90% to 100%.

5.82 In the absence of the additional test, an SBT loss would only need to pass the same business test when transferred the first time. It could then effectively be transferred subsequently without further SBT testing. That result would be contrary to the way in which the loss would be treated had it not been transferred at all. That is, in order to deduct the loss outside a consolidated group, the loss entity's business immediately before the ownership change is compared with its business in the claim year. The additional test ensures that this is effectively what will happen each time an SBT loss is sought to be transferred.

#### ***Transfer test – pattern of distributions***

5.83 The pattern of distributions test is one of the loss recoupment tests for non-fixed trusts. The test is triggered where there is a distribution of income in the loss claim year and in at least one of the 6 earlier income years. The test is also triggered where there is a distribution of capital in the loss claim year and in at least one of the 6 earlier income years.

5.84 The test requires a comparison of the distribution made in the loss claim year with distributions made in the 6 earlier income years. The test is passed if more than 50% of a trust's income and capital distributions are made (directly or indirectly) for each of the test years to the same individuals.

5.85 Before a loss can be transferred to a head company, it is tested to ascertain whether it can be utilised during the trial year – usually a period commencing 12 months before the joining time and ending just after the joining time. Normally, the pattern of distributions test requires an examination of trust distributions made in test income years. Where a trust joins the group part way through its income year, the trial year does not match an income year. This makes it difficult to determine the test income years and their distributions.

5.86 Therefore, where the pattern of distributions test is applied as a transfer test, the trial year is modified to be the income year in which the trust joins the consolidated group. [*Schedule 1, item 1, subsections 707-130(1) to (3)*]

5.87 A trust may make a distribution after the time it joins a group. In working out whether this distribution is counted in determining if the pattern of distributions test is passed as a transfer test, the test only takes account of distributions that are attributable to income or capital of the trust *before* the joining time. [*Schedule 1, item 1, subsection 707-130(4)*]

## Transferring part year losses

5.88 Special rules are required to ensure that losses referable to only part of an income year can be transferred, and are tested on transfer over a period that reflects the fact that they were effectively made for a shortened income year. [*Schedule 1, item 1, Subdivision 707-E*]

5.89 A loss referable to part of an income year may be made by the joining entity for the income year in which it joins the group or a prior income year.

### *Loss made in the joining year*

5.90 A joining entity may make a part year loss in the joining year where it joins a group part way through its income year.

#### *Single entry case*

5.91 In this scenario the entity joins the group part way through the income year and remains in the group until the end of the income year.

5.92 After the joining time, the single entity rule treats the entity as part of the head company. Therefore, for that income year, the only period relevant to the entity as a single entity is the period from the start of the income year until the joining time. The entity is required to work out its taxable income for this period. [*Schedule 1, item 1, section 701-1*]

5.93 If the joining entity has a loss referable to the pre-consolidation period then that will be the entity's loss for the income year. (The entity has remained with the group until the end of the income year so there is no post-consolidation period to consider.)

5.94 However, in the absence of any further rules the loss would not be available for transfer. Only losses made for an income year that ends *before* the joining time can be transferred. This loss is for an income year that ends *after* the joining time.

5.95 Therefore, for loss transfer purposes, the joining entity is taken to make the loss for an income year that starts at the start of the joining income year and ends just before the joining time. [*Schedule 1, item 1, section 707-600, item 1 in the table*]

#### *Multiple entry case*

5.96 Before joining the group, the entity may already have exited another group so that, in the one income year, it ceased to be a subsidiary member of a group, operated as a single entity and then joined a new group as a subsidiary member. In that case it will be required to work out a taxable income or loss for the period that starts when it left the first group and ends when it joins the second group as though that period were an income year. [*Schedule 1, item 1, section 701-45*]

5.97 However, a loss amount worked out for the period will not be an actual loss for the income year. An entity can only have one loss for an income year and that status is reserved for any loss amount made in a post-consolidation period (if the entity were to leave the group before the end of the income year without becoming a subsidiary member of another group). This is because this post-consolidation loss is available to be carried forward by the entity for use in a future income year, whereas loss amounts made for a pre-consolidation period are to be transferred or cancelled (i.e. they are not ever available for future use by the joining loss entity). [*Schedule 1, item 1, subsection 701-45(8)*]

5.98 For that reason, it is necessary to ascribe to the pre-consolidation loss amount in this scenario actual loss status for the purpose of applying the transfer rules. This ensures the amount can be transferred as a loss. [*Schedule 1, item 1, section 707-600, item 2 in the table*]

5.99 Further, the loss will be taken to have been made for an income year starting at the start of the period and ending just before the joining time. This ensures that in determining whether the loss can be transferred the entity's ownership is tested only from the start of the period. (The definition of 'trial year' ensures that, if appropriate, the entity's business is also only tested from the start of the period.) [*Schedule 1, item 1, section 707-600, item 2 in the table*]

#### ***Loss made in a prior year***

5.100 A joining entity may make a part year loss for an income year prior to the joining year if it exited another group part way through the prior year.

5.101 The entity is required to work out its taxable income or loss for the period from the leaving time until the end of the income year. If the amount is a loss then it will be the entity's loss for the whole of that (prior) income year. [*Schedule 1, item 1, section 701-1 and subsection 701-45(8)*]

5.102 The loss is made for an income year that ends prior to the joining time (which in this scenario does not take place until the next income year). Therefore, the loss can be transferred.

5.103 However, the loss is taken to be a loss for an income year that starts at the leaving time and ends at the end of the (prior) income year. This ensures that, in determining whether it can be transferred, the joining entity is tested only from the time it left the previous group until it joins the new group. [*Schedule 1, item 1, section 707-600, item 3 in the table*]

5.104 Rules will be developed to ensure that the entity is tested over the appropriate period if it seeks to use the loss itself instead of transferring it to another consolidated group.

## How is a transferred loss treated in the hands of the head company?

5.105 A loss transferred to a head company is taken to be made by the head company for the income year in which the transfer occurs. This means the loss may be used by the head company. In determining whether it can be used the head company applies the general COT and, if that is failed, the SBT.

5.106 Other effects of transferring a loss to a head company are:

- transferred losses retain their original loss type;
- transferred losses are classified as COT losses, SBT losses or neither; and
- losses transferred by a particular joining entity constitute a bundle which is assigned a loss factor – this is discussed in Chapter 7.

### *The head company is taken to have made the transferred loss*

5.107 The loss is taken to have been made by the head company to which it is transferred. An entity that joins a group as a subsidiary member is no longer able to use the loss. [Schedule 1, item 1, subsection 707-140(1)]

5.108 This means the loss may be used by the head company in working out its taxable income (subject to limitations) or may be transferred to another group of which the head company becomes a wholly-owned subsidiary.

5.109 A transferred loss will continue to be taken as having been made by the head company to which it is transferred, unless the loss is transferred again. This means the limits on the use of transferred losses will continue to apply to an entity even if it ceases to be a head company because, for example, it becomes a non-resident.

### *A transferred loss is taken to have been made for the transfer year*

5.110 A transferred loss is taken to have been made by the head company for the income year in which the transfer occurs. [Schedule 1, item 1, subsection 707-140(1)]

5.111 Also, it may be used by the head company in the same income year in which the transfer occurs. This overrides the general rule that an entity may only deduct or apply losses from earlier income years, thereby matching the existing loss transfer rule in section 170-15 of the ITAA 1997. [Schedule 1, item 1, subsection 707-140(2)]

5.112 However, where a debt of the head company is forgiven (in accordance with Subdivision 245-B in Schedule 2C to the ITAA 1936) in

the income year in which the loss transfer occurs, subsections 245-105(5) and (6) apply as if the head company made the transferred loss for an earlier year. This ensures the loss can be reduced by the net forgiven amount of the debt as only prior year losses can be reduced under the debt forgiveness rules. [*Schedule 1, item 1, subsection 707-140(3)*]

***Transferred losses retain their original loss type***

5.113 The different loss types are tax losses (including film losses), net capital losses and foreign losses. All losses retain their status as one of these types, even after transfer. Each type is a *sort of a loss*.

***Transferred losses are classified as SBT, COT (or neither)***

5.114 An ***SBT loss*** is one that has been transferred because the joining entity satisfied a same business test. [*Schedule 1, item 1, subsection 707-135(2)*]

5.115 A transferred loss that has passed the ownership test may still be classified as an SBT loss. For example, a company may pass the ownership test, fail the control test, but pass the same business test. The loss will be classified as an SBT loss because, in the end, passing the same business test was the reason the loss was able to be transferred.

5.116 SBT losses are *not* subject to further business testing in the hands of the head company unless the head company fails the COT or seeks to transfer the loss again.

5.117 A COT loss is, broadly, one that has been transferred because the joining entity satisfied an ownership test. [*Schedule 1, item 1, section 707-215*]

5.118 However, a ***COT loss*** is defined as one that has been transferred for a reason *other than* that it passed a same business test or there were no restrictions on its transfer.

5.119 The way in which a loss is classified is relevant:

- in determining whether the loss can be used by a head company:
  - special rules apply in determining whether a COT loss transferred to a head company by another company can be used (see Chapter 6);
- in determining which of the 2 methods for limiting the use of transferred losses applies:
  - the more generous concessional method for using transferred losses may only be used for some COT losses transferred by a company (see Chapter 8); and
- in applying the same business test as a transfer test:

- losses that have previously been transferred as SBT losses can only be transferred again if they satisfy an additional same business test (see paragraphs 5.74 to 5.82).

### **Cancelling the transfer of a loss**

5.120 A head company can choose to cancel the transfer of a loss. The choice cannot be revoked. If the choice is made, the transfer is taken never to have occurred which means that the loss itself is effectively cancelled in that it can never be used by any entity.

5.121 A head company may wish to cancel a loss transfer to avoid adjusting the rate at which it can use its existing transferred losses. The rate of use of transferred losses is discussed in Chapter 7. The cancellation of a loss transfer may also affect the calculation of the allocable cost amount for the joining loss entity (discussed in Chapter 4).

### **The effect on the joining entity**

5.122 A loss transferred by an entity that becomes a subsidiary member may never be used by the entity.

5.123 The single entity rule means a transferred loss is not available for use by a subsidiary while it is a member of the group. The exit clean slate rule prevents it using the loss after it leaves the group. The exit clean slate rule essentially wipes away anything that happened to the entity before the leaving time. [*Schedule 1, item 1, sections 701-1 and 701-10*]

5.124 A loss that is unable to be transferred is effectively cancelled. If the head company chooses to cancel the transfer of a loss, the transfer is taken not to have occurred. In either case, the loss may never be used by any entity for an income year ending after the joining time. [*Schedule 1, item 1, sections 707-145 and 707-150*]

### **Application and transitional provisions**

5.125 The consolidation regime will apply from 1 July 2002.

### **Consequential amendments**

5.126 Consequential amendments have been made to subsection 995-1(1) of the ITAA 1997 to include references to new dictionary terms.

**Appendix A: Which loss tests apply to which entities**

<i>These entities</i>	<i>Apply these loss tests</i>			
	<b>Ownership<sup>1</sup></b>	<b>Control</b>	<b>Same business</b>	<b>Pattern of distribution</b>
company	✓	✓	✓	
listed public company (and 100% owned subsidiary)	✓	✓	✓	
ordinary fixed trust	✓			
unlisted widely held trust	✓			
unlisted very widely held trust	✓			
wholesale widely held trust	✓			
non-fixed trust	<i>-(if applicable)</i>	✓		<i>-(if applicable)</i>

<sup>1</sup> This refers to:

- the COT for companies;
- the substantial COT for listed public companies and their 100% owned subsidiaries; and
- the 50% stake tests for trusts.



---

## **Chapter 6**

# ***Determining whether a transferred loss can be used by a consolidated group***

---

### **Outline of chapter**

6.1 This chapter explains rules that will apply in determining whether a transferred loss can be used by a head company (i.e. whether it can be deducted or applied by the head company or transferred to another group). The rules are in the form of modifications to the general loss recoupment tests for companies.

6.2 The rules that limit the amount of a transferred loss that can be deducted or applied are discussed in Chapter 7.

### **Context of reform**

6.3 The first modification complements the consolidation loss transfer rules. Losses that pass modified versions of the general loss recoupment tests are transferred at the joining time. These losses are taken to be made by the head company for the income year in which the transfer occurs. In determining whether a loss transferred part way through the head company's income year can be used by the head company, things that happen to the head company before the transfer are ignored.

6.4 This reflects the fact that the loss has already been tested up to the transfer time. In the absence of this rule, things that happen to the head company before the transfer may be taken into account a second time in determining whether the head company can use the loss.

6.5 The second modification matches the broad policy that, to the greatest extent possible, the consolidation regime should not promote a faster or greater use of losses than would have occurred otherwise. For that reason, pre-consolidation changes in the ownership of a transferor loss company will be relevant in determining whether its losses can be used by any head company to which they are transferred.

### **Summary of new law**

6.6 In determining whether a loss transferred to a head company part way through the company's income year can be used by the company, the loss year is taken to have started at the transfer time.

6.7 However, if the loss is a COT loss transferred to the head company by another company, pre-consolidation ownership changes in the entity that actually made the loss are relevant (though intra-group changes post-consolidation are not). The pre-consolidation changes are measured from the start of the actual loss year. *[Schedule 1, item 1, Subdivision 707-B]*

## Comparison of key features of new law and current law

<i>New law</i>	<i>Current law</i>
For a loss transferred to a head company part way through the company's income year the loss year is taken to start at the transfer time.	Transferred losses are taken to be made by the transferee in the same income year in which they were made by the transferor.
Ownership of a loss company is tested, subject to certain assumptions, from the start of the loss year until the end of the income year for which the head company seeks to use the loss.	Ownership of a company seeking to use a prior year loss is tested from the start of the loss year until the end of the loss claim year.

## Detailed explanation of new law

### Modification of the loss year for a transferred loss

6.8 Broadly, only things that happen to the head company *after* a loss has been transferred to it are relevant in determining whether the company can use that loss.

6.9 The head company to which a loss is transferred is taken to have made the loss for the income year in which the transfer occurs. However, if the transfer occurs part way through the head company's income year, then the loss year is modified so that it starts at the transfer time. *[Schedule 1, item 1, section 707-205]*

6.10 Essentially this means that the ownership test period starts at the transfer time (i.e. changes in the ownership or control of the head company before that time are not relevant in determining whether the loss can be used).

### The ownership history of a company COT loss is preserved

6.11 This rule applies to a COT loss transferred to a head company by another company. Broadly, in determining whether the loss can be used by the head company, pre-consolidation ownership changes in the loss company are recognised (including those that led to it joining the group). However, the only post-consolidation changes that are relevant are those that occur to the head company (i.e. intra-group changes are ignored).

***What is the purpose of this rule?***

6.12 The purpose of the rule is to preserve the effect of sections 165-165 and 166-170 of the ITAA 1997. These provisions operate so that the only shares and interests to be counted in determining whether a company has passed the COT are exactly the same shares and interests held by the same persons.

6.13 The rule ensures that pre-consolidation changes in ownership of a loss company continue to count in determining whether the COT is passed in respect of the loss post-consolidation. In particular, changes below the head company level that would otherwise be erased as a result of the loss being transferred to the head company continue to be counted.

6.14 Ignoring such changes would place consolidated groups at a considerable advantage over non-consolidated companies.

***The rule***

6.15 The rule applies to a loss transferred to a head company as a COT loss by another company. In determining whether the head company can use the loss, the head company is taken to have passed the COT (in section 165-12 of the ITAA 1997) only if the entity that actually made the loss (the *initial loss-maker*) would have met those conditions assuming:

- the initial loss-maker could have used the loss; and
- there are no changes in the head company's interests in the initial loss-maker after it joined the group.

*[Schedule 1, item 1, subsections 707-210(1), (2) and (3)]*

6.16 So the head company passes the COT if the initial loss-maker would have passed on the basis of the assumptions. This involves applying the COT rules applicable to the initial loss-maker.

6.17 A failure of the COT by the initial loss-maker is attributed to the head company to enable it to apply the appropriate SBT. *[Schedule 1, item 1, subsections 707-210(4) and (5)]*

***When does the rule apply?***

6.18 The rule applies in determining whether a head company can deduct or transfer a COT loss transferred to it by another company. *[Schedule 1, item 1, subsection 707-210(1)]*

6.19 It only applies to a loss transferred by a company. It does not apply to a loss transferred by a trust. Changes in ownership of a trust are not taken into account in determining whether its losses can be used by a group. However, changes in ownership of a head company to which a trust loss is transferred are relevant.

6.20 The rule only applies to COT losses. It is not relevant, for example, in determining whether the head company has passed the COT in respect of an SBT loss.

6.21 It is only relevant in determining whether the COT is passed. If after applying the rule the COT is failed, that failure is attributed to the head company and the SBT is then applied to the head company (and not the initial loss-maker). The control test is also applied to the head company. *[Schedule 1, item 1, subsections 707-210(4) and (5)]*

### ***The first assumption***

6.22 The first assumption, as it applies to an initial loss-maker that is a subsidiary member, turns off the rule that the loss is now taken to have been made by the head company. This reinstates the loss as having been made by the initial loss-maker for the income year in which it was actually made (though only for the purpose of the rule). *[Schedule 1, item 1, subparagraph 707-210(3)(a)(i)]*

6.23 Where the initial loss-maker and the head company are the same entity the assumption simply reinstates the original loss year. *[Schedule 1, item 1, subparagraph 707-210(3)(a)(ii)]*

### ***The second assumption***

6.24 The second assumption is that, after the transfer, no CGT event has happened to a membership interest in the initial loss-maker held directly or indirectly by a member of the group. This assumption ensures that, consistent with the single entity principle, intra-group ownership changes are ignored in determining whether the loss can be used by the group. *[Schedule 1, item 1, paragraph 707-210(3)(b)]*

6.25 This assumption works because at the joining time the head company must generally hold, directly or indirectly, 100% of the membership interests in the initial loss-maker. By assuming there is no change in that holding post-consolidation, any changes in the ownership of the head company can be taken to be changes, in the same percentage, to the initial loss-maker. This equates to only testing changes above the head company level and ignoring those below.

6.26 The second assumption will also override an initial loss-maker's exit from the group. This ensures that the head company can use the loss even if the initial loss-maker has left the group. Also, any ownership changes leading to that exit would not be counted in determining whether the head company could use the loss. This is consistent with the general consolidation model which is that tax attributes are transferred to the group at the joining time and remain with the group (for use by the group) even if the entity that transferred those attributes leaves the group.

### ***The initial loss-maker is a trust***

6.27 Changes in the ownership of the trust are not taken into account in determining whether losses transferred by it to a head company can be used by the company. Only changes in the head company after the transfer time are relevant.

6.28 This is ensured by 2 rules:

- first, all transferred losses are refreshed in that they are taken to have been made by the head company for the income year in which they are transferred; and
- second, the head company's loss year is taken to start at the transfer time for the purpose of determining whether it can use the trust loss or transfer it to a new head company. [*Schedule 1, item 1, subsection 707-140(1) and section 707-205*]

6.29 The initial loss-maker is the first company to have made the loss. So if the loss was originally made by a trust, the initial loss-maker is the head company to which the loss was first transferred. [*Schedule 1, item 1, subsections 707-210(2) and (6)*]

### ***What happens if losses are transferred more than once?***

6.30 If the losses are transferred again, there is an additional assumption. It is that the new head company's interest in the former head company does not change after the joining time. This additional assumption applies as many times as the losses are transferred. [*Schedule 1, item 1, paragraph 707-210(3)(c)*]

6.31 Therefore, once the initial loss-making company, or any company to which the loss is subsequently transferred, joins a consolidated group it is assumed that the group's ownership of the entity remains unchanged from the joining time until the loss is sought to be utilised.

### ***An initial loss-maker's COT failure is attributed to the head company***

6.32 If, as a result of applying the rule, the initial loss-maker would have failed the COT, then the head company is taken to fail the COT.

6.33 The time at which the head company is taken to fail is relevant in applying the SBT to the head company. It is determined by reference to the time it would have been failed by the initial loss-maker. That time depends on whether the initial loss-maker is an ordinary company to which Division 165 applied or a listed public company (or 100% subsidiary) to which Division 166 applied.

6.34 The head company is taken to have failed the COT at the time the initial loss-maker would have failed if Division 165 applied to the initial loss-maker. The head company is taken to have failed the COT just before

the end of the initial loss-maker's test time that triggered the failure if Division 166 applied. The test time will have been the time of abnormal trading in the initial loss-maker or the end of the initial loss-maker's income year. *[Schedule 1, item 1, subsection 707-210(4)]*

6.35 Regardless of whether Division 165 or 166 has applied to the initial loss-maker, a further link rule is needed to ensure that the SBT can be applied if Division 166 applies to the head company. The rule deems the time described in paragraph 6.34 to be the head company's test time for the purpose of applying the SBT in subsection 166-5(5) of the ITAA 1997. *[Schedule 1, item 1, subsection 707-210(5)]*

*Interaction with the modified SBT*

6.36 If the head company is applying the rule to determine whether it can transfer the loss to a new group, then these rules that determine timing of a COT failure must interact correctly with the modified SBT that applies on transfer.

6.37 First, the timing of the head company's COT failure will be plugged into the modified SBT. This means the head company may be required to test its business for the whole of the income year in which it is taken to have failed the COT. *[Schedule 1, item 1, subparagraph 707-125(4)(a)(ii) and subsection 707-125(5)]*

6.38 Second, the modification to subsection 166-5(5) discussed in paragraph 6.35 will have no application to the modified SBT which makes its own (and different) modifications to the SBT test time for listed public companies. *[Schedule 1, item 1, subsection 707-125(6)]*

**Example 6.1**

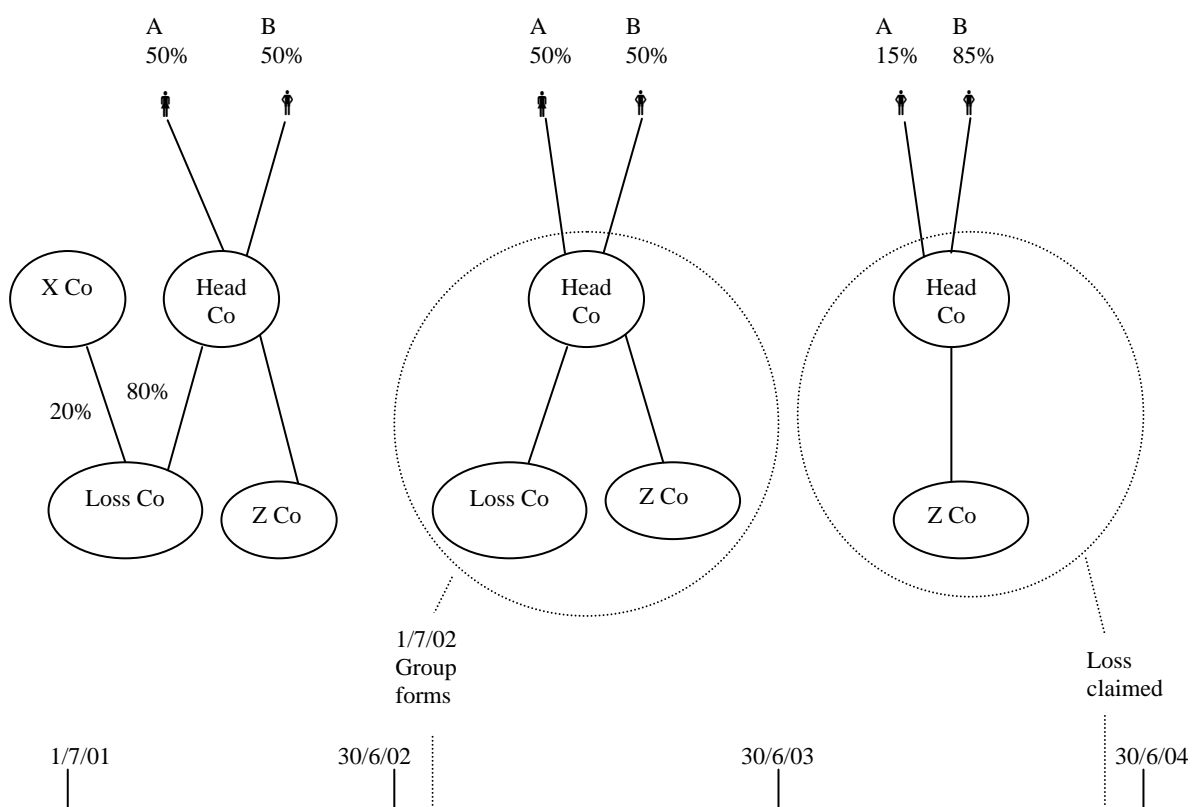

The loss year is the year ending 30 June 2002.

**Transferring the loss to Head Co**

Head Co chooses to form a consolidated group from 1 July 2002. At this point Loss Co's loss is tested to determine whether it is transferred to Head Co. (The rule that preserves the history of a COT loss does not apply to the *initial* transfer of a loss so is not relevant at this point.)

Assume that all shares in the example carry equal voting, and dividend and capital distribution rights. Head Co acquired X Co's 20% interest in Loss Co before the group consolidated. There were no other changes in the ultimate individual ownership of Loss Co. The loss is therefore transferred to Head Co as a COT loss.

**Head Co seeks to use the loss for the 2003-2004 income year**

For this purpose the rule that preserves the ownership history of a COT loss applies. Head Co can use the loss if Loss Co could have used it assuming there were no changes in Head Co's interest in Loss Co after Loss Co joined the group.

Between the time the group was formed and the end of the loss claim year (30 June 2004) Head Co disposed of Loss Co and, as a result, Loss Co has left the group. However, that is irrelevant in determining whether Head Co can use the loss. It is assumed that Head Co has retained an unchanged 100% interest in Loss Co during the whole of that time.

*However*, after the group formed, A sold 35% of its interest in Head Co to B. By itself, this sale would not cause Head Co to fail the COT. But because the rule requires examination of Loss Co's ability to claim the loss, the 20% change that occurred prior to consolidation (when Head Co acquired X Co's 20% interest in Loss Co) is also relevant.

When the pre-consolidation changes in Loss Co are added to the post-consolidation changes in Head Co it can be seen that there has been a 55% change in the ownership of Loss Co. This means that Head Co fails the COT and so can only deduct the loss if it passes the SBT.

## **Application and transitional provisions**

6.39 The consolidation regime will apply from 1 July 2002.

## **Consequential amendments**

6.40 Consequential amendments have been made to subsection 995-1(1) of the ITAA 1997 to include references to new dictionary terms.



---

# **Chapter 7**

## ***Limiting the use of transferred losses by a consolidated group***

---

### **Outline of chapter**

7.1 This chapter explains how much of a transferred loss may be deducted or applied by a head company.

### **Context of reform**

7.2 The use of transferred losses by a consolidated group is restricted so that losses will be used by a group at approximately the same rate they would have been used by the joining entity had it remained outside the group. The aim is to ensure that the treatment of transferred losses is not a motive in deciding to consolidate a group or in a consolidated group deciding to acquire a loss entity.

7.3 For that reason, the maximum amount of losses transferred by a joining entity that can be used by the group in an income year is determined by reference to the amount of the group's income considered to have been generated by the joining entity. The loss factor is a proxy for determining this amount.

7.4 The loss factor method departs from Recommendation 15.3 of *A Tax System Redesigned*. It was developed in consultation with interested taxpayers and their advisers. To date that consultation has proceeded on the basis that the loss factor method would apply only to transferred losses. It is proposed that interested taxpayers and their advisers also be consulted on whether the loss factor method should be extended so as to apply to losses generated by a consolidated group if the group acquires a new member entity. Issues to consider include whether such an extension is warranted and the manner in which it would interact with the already developed rules for calculating and adjusting loss factors for transferred losses.

7.5 In addition, a concessional method for the use of transferred losses has been developed in recognition of this departure. The concession applies to a group that consolidates during the transitional period and is discussed in Chapter 8.

## Summary of new law

7.6 First, losses generated by the consolidated group must effectively be used *before* transferred losses.

7.7 Second, the annual rate at which a head company can deduct or apply transferred losses is limited by their loss factor. The loss factor is basically the proportion that the loss entity's market value at the joining time bears to the value of the whole group at that time.

## Comparison of key features of new law and current law

<i>New law</i>	<i>Current law</i>
A head company's use of transferred losses is limited by the loss factor (unless the concessional method also applies). That means the transferred losses shelter income that would have been earned by the <i>transferor</i> .	Losses may be transferred to the extent they can be used by the <i>transferee</i> .

## Detailed explanation of new law

7.8 A head company is taken to have made any losses transferred to it, but its rate of utilisation of them is subject to an annual limit.

### How does a head company recoup its losses?

7.9 A head company works out its taxable income as if each of the other entities in the consolidated group were a part of the head company.

7.10 In doing that, there are 2 broad categories of carry forward losses that a head company may use to reduce its income. They are:

- losses generated by the consolidated group (*group losses*); and
- losses generated by an entity before it became a member of the group and which it transfers to the head company on joining the group (*transferred losses*).

7.11 Group losses are deducted or applied by the head company in accordance with the existing rules.

7.12 However, the rules are modified whenever the head company seeks to use transferred losses. Broadly, the modifications ensure that group losses are used ahead of transferred losses and that the annual rate at which transferred losses can be used is limited.

***How do the consolidation modifications interact with the general loss rules?***

7.13 The modifications to accommodate transferred losses simply overlay the existing loss rules – they do not displace the scheme of the current loss rules.

7.14 The modifications are not a code for whether and how a loss can be deducted. Rather, they set the *maximum* amount of a transferred loss that can be claimed annually. The general rules are then applied in determining how much of that maximum amount can in fact be claimed.

7.15 For example, the general loss rules still apply to ensure that transferred capital, foreign and film losses are quarantined in that they may only be offset against group income of the same type. Also, the head company must still satisfy the COT or SBT in order to deduct or apply a transferred loss (though the COT is modified for these purposes in respect of COT losses transferred by a company – see Chapter 6).

**Classifying losses held by a consolidated group**

7.16 The use of losses by a consolidated group depends on how they are classified.

***Group losses versus transferred losses***

7.17 These are the broadest categories. Group losses must effectively be used before transferred losses.

***Transferred losses: bundles of losses***

7.18 All transferred losses belong to a loss bundle.

7.19 Loss bundles are formed when losses are transferred to a group for the first time by the entity that actually made them. All of the losses transferred by the entity that actually made them constitute a single ***bundle*** of losses. A bundle may contain only one loss.

7.20 However, losses may be transferred out of or into the bundle under the value donor concession discussed in Chapter 8.

7.21 A loss will cease to form part of a bundle of losses once it can no longer be used (e.g. it has been fully deducted or reduced).

7.22 A loss bundle remains intact if it is transferred again.

7.23 The losses in a bundle must all have been transferred at the same time. Were the loss entity to leave and subsequently rejoin the group, any losses transferred when rejoining would form a separate loss bundle.

7.24 A single loss factor is worked out for each loss bundle. The loss factor is used to limit the annual rate at which transferred losses may be recouped by the head company. The calculation and adjustment of loss factors are discussed in paragraphs 7.40 to 7.76.

### **How are the general loss rules modified for transferred losses?**

7.25 These modifications apply in determining how much of a transferred loss may be deducted or applied by a head company:

- group losses of a sort are effectively used ahead of transferred losses of the same sort:
  - this matches the way the current group loss transfer rules work. Under those rules, a company can only benefit from a transferred loss after using all of its own losses. After introduction of the consolidation regime, the current group loss transfer rules contained in Division 170 of the ITAA 1997 will only apply to transfers involving an Australian branch of a foreign bank;
  - a transferred loss may be used in the same income year in which the head company is taken to have made it; and
  - this overrides the general rule that an entity may only deduct or apply losses from *earlier* income years. It matches the existing loss transfer rule in section 170-15 of the ITAA 1997; and
- the annual rate at which transferred losses can be used is limited by their loss factor:
  - a loss factor is worked out separately for each loss bundle.

7.26 The general rule that requires earliest losses to be used before later ones has no application within a bundle because all of the losses in a bundle will be taken to have been made in the same income year (i.e. the income year in which they were transferred).

7.27 However, losses in different bundles will have different ages if the bundles were acquired by the head company in different income years. There is no requirement that a bundle containing earlier losses must be exhausted before drawing upon a bundle containing later losses (i.e. there is no ordering between bundles).

7.28 The modifications to the way in which the COT applies to a head company seeking to use a transferred loss (discussed in Chapter 6) may also be relevant. Also, the SBT, if relevant in determining whether a head company can use (or transfer) a loss, is applied to the activities of the whole group – this flows from the single entity rule that treats subsidiary entities as parts of the head company.

## Limit for using transferred losses

7.29 The use of transferred losses is limited by their loss factor.

### *What is the purpose of the loss factor?*

7.30 The loss factor is a proxy for determining the proportion of the group's income generated by the loss entity. Its calculation is discussed in paragraphs 7.40 to 7.76. A proxy is necessary because, immediately after joining, the loss entity's activities are, for income tax purposes, merged with those of the head company so it is not possible to determine the amount of the group's income actually generated by the loss entity.

7.31 The loss factor limit ensures that transferred losses are used up at approximately the same rate they would have been used had the loss entity remained outside the group. The aim is to ensure that the decision to consolidate is not driven by the tax treatment of transferred losses.

7.32 If the loss entity later leaves the consolidated group, its losses remain with the head company of the group. The loss factor attributable to the losses continues to be used to determine the amount of them that can be deducted or applied by the head company. While a loss entity that leaves a group ceases to contribute income to the group, the cash or assets received by the group on the sale of the loss entity continue to generate income for the group, leaving the group's income generating capacity unchanged.

### *Applying the loss factor*

7.33 The loss factor for a bundle is applied to each category of group income or gains. The results are taken to be the head company's only income or gains of each type. On the basis of that assumption, the head company works out the maximum amount of losses of each sort it can use from the bundle.

7.34 The categories reflect the general loss quarantining rules and therefore cover:

- capital gains;
- foreign income;
- film income;
- other assessable income; and
- exempt income.

7.35 Before applying the loss factor, each income or gain category is reduced by any relevant deductions, including unused group losses.

### Example 7.1

The Farrah Fabrics consolidated group consists of a head company and 3 subsidiaries. Two of the subsidiaries transferred losses to the head company when the group consolidated on 1 December 2002.

The head company of the Farrah Fabrics group is now working out the group's taxable income for the 2003-2004 income year.

The group's capital gains for the income year are \$900. The group's capital losses for the income year are \$200.

The group's only other assessable income is \$9,000. Its deductions relating to that income are \$990. Its group tax loss carried forward from the previous income year is \$60.

The group's remaining *transferred losses* at that time, and their loss factors, are set out in the table.

<i>Loss bundle</i>	<i>Loss factor</i>	<i>Unused transferred losses</i>
Bundle 1	0.146	\$50 net capital losses \$3,000 tax losses (not film)
Bundle 2	0.214	\$100 net capital losses \$5,000 tax losses (not film)

#### Step 1: Work out the categories of group income or gains

Category: capital gains

Reduce the group's capital gains for the income year by its group capital losses for that year:  $\$900 - \$200 = \$700$

Category: other assessable income

Reduce other assessable income by current year deductions and prior year group tax loss:  $\$9,000 - (\$990 + \$60) = \$7,950$

#### Step 2: Apply the loss factors to the categories to work out the group income and gains attributable to each bundle

Category: capital gains

Bundle 1:  $0.146 \times 700 = 102$

Bundle 2:  $0.214 \times 700 = 150$

Category: other assessable income

Bundle 1:  $0.146 \times 7,950 = 1,160$

Bundle 2:  $0.214 \times 7,950 = 1,701$

#### Step 3: Work out the maximum losses to be used from each bundle

Net capital losses

The results of applying the loss factors to the capital gains category equals the maximum amount of net capital losses that can be used from each bundle (Bundle 1: 102; Bundle 2: 150).

However, the net capital losses in each bundle are less than their respective maximums. So the total net capital losses in each bundle can be used.

The net capital gains attributable to each bundle are those remaining after deducting relevant transferred net capital losses. The net capital gains attributable to each bundle are relevant for determining the maximums for transferred tax losses. They are:

$$\text{Bundle 1: } 102 - 50 = 52$$

$$\text{Bundle 2: } 150 - 100 = 50$$

#### Tax losses

The maximum transferred tax losses that can be used is dictated by the amount of assumed income against which tax losses can be deducted. This includes the amounts worked out under step 2 for the 'other assessable income' category and the net capital gain amounts from above:

$$\text{Bundle 1: } 1,160 + 52 = 1,212$$

$$\text{Bundle 2: } 1,701 + 50 = 1,751$$

#### **Step 4: Work out Farrah Fabric's net capital gain**

<i>Capital gains (\$)</i>		<i>Capital losses (\$)</i>	
capital gain	900	group capital losses	200
		net capital losses (bundle 1)	50
		net capital losses (bundle 2)	100
<b>Total</b>	<b>900</b>	<b>Total</b>	<b>350</b>

Therefore, Farrah Fabric's net capital gain is \$550 (\$900 – \$350)

#### **Step 5: Work out Farrah Fabric's taxable income**

<i>Assessable income (\$)</i>		<i>Deductions (\$)</i>	
net capital gain	550	deductions	990
other	9,000	group loss	60
		tax losses (bundle 1)	1,212
		tax losses (bundle 2)	1,751
<b>Total</b>	<b>9,550</b>	<b>Total</b>	<b>4,013</b>

Farrah Fabric's taxable income is \$5,537 (\$9,550 – \$4,013)

#### ***The loss factor applies for only part of the income year***

7.36 The use of transferred losses is apportioned if their loss factor applied for only part of the income year. That will occur if:

- the losses were transferred to the head company after the start of the head company's income year; or
- the loss factor is adjusted during the year to take account of the transfer of another loss bundle or because there has been a capital injection or a non-arm's length transaction (in these cases the loss factor will have different numerical values for different periods of the income year).

7.37 Apportioning the use of losses transferred part way through the head company's income year is consistent with the loss factor being a proxy for determining the proportion of the group's income generated by the loss entity. In the absence of an apportionment rule, losses transferred by an entity that joins a group on, for example, the second last day of the group's income year, could be used in reducing the group's income for the whole of the income year (i.e. for a period during which the joining entity was not a member of the group and so could not have contributed to the income generated by the group).

7.38 Apportioning the use of losses if their loss factor is adjusted during the income year ensures that an adjusted loss factor only applies from the date of the event that triggered the adjustment (i.e. the acquisition of a new loss entity or a capital injection). This matches the treatment of losses transferred to a head company part way through its income year.

7.39 Broadly, the apportionment will involve the following steps:

- first, for each loss factor that applied to the bundle during the income year, work out the maximum loss that could have been used had each loss factor applied for the whole income year;
- second, apportion each amount on the basis of the number of days in the income year for which that loss factor was relevant; and
- third, add the results of the second step.

### **Calculating the loss factor**

7.40 The loss factor is basically the proportion the joining entity's market value bears to the market value of the whole group at the joining time. Loss factors are calculated for loss bundles whenever they are transferred to a group.

#### ***Calculating a loss factor for losses transferred for the first time***

7.41 Losses transferred for the first time may be either:

- the losses of a single entity that becomes the member of a consolidated group; or



- the group losses of a head company that is acquired by another group.

7.42 In these cases, the loss factor is calculated using the following

$$\frac{\text{modified market value of the loss entity or group}}{\text{value of the joined group}}$$

formula:

7.43 Values are worked out as at the joining time and are discussed in paragraphs 7.60 to 7.67. The joined group is the whole group, including the loss entity.

***Adjusting the loss factor***

7.44 A group's loss factors are adjusted whenever the group acquires another loss entity (or group) or the group's market value is increased as a result of a capital injection or a non-arm's length transaction. A group's loss factors must also be adjusted if they total more than one. These are referred to as adjustment events.

7.45 Table 7.1 identifies the adjustment events. The adjusted loss factor is worked out by multiplying the existing loss factor by the formula identified at the relevant item in the table. An adjustment event can never result in an increased loss factor.

**Table 7.1: Loss factor adjustments**

<i>Item no.</i>	<i>Adjustment event</i>	<i>Formula</i>
1	Previously transferred loss bundles are transferred to a new head company.	$\frac{\text{market value of the old group}}{\text{market value of the new joined group}}$
2	Previously transferred loss bundles are transferred to a new head company and, at the same time, the old group also transfers its group losses to the new head company.	$\frac{\text{loss factor for group losses}}{\text{the total of loss factors for all bundles being transferred}}$ (If the loss factor for group losses is more than one, reduce it to one.)
3	Existing group with transferred losses acquires new loss bundles.	$1 - \text{the total of the loss factors for all the new loss bundles that have been transferred to the head company}$
4	There is an increase in the market value of the group as a result of an injection of capital or a non-arm's length transaction.	$\frac{\text{market value of the group just before the event}}{\text{market value of the group just before the event} + \text{amount of the increase}}$
5	Loss factors total more than one.	$\frac{1}{\text{total of loss factors}}$

*Adjustment event 1 – previously transferred losses are transferred again*

7.46 This event occurs when:

- a head company of a consolidated group (the old group) joins another consolidated group (the new group);
- the old group transfers losses to the new group; and
- the losses had been previously transferred to the old group.

7.47 The loss factor for the previously transferred losses is adjusted by multiplying it by the formula at item 1 in Table 7.1. The market value of the old group is included in the numerator as if the group had continued to exist. The market values of the old and new groups are worked out as at the joining time. The new group includes the old group.

7.48 Unlike the formula for calculating loss factors for losses transferred for the first time, this formula does not use modified market value. This is because the original loss factors were calculated to take account of the assumptions in paragraph 7.60. Therefore, they can simply be adjusted so they reflect the market value of the old and new groups at the joining time.

*Adjustment event 2 – previously transferred and group losses are both transferred*

7.49 This event occurs when the old group transfers to the new group both previously transferred losses and its own group losses. First, the loss factor for the group losses is worked out using the formula for losses transferred for the first time. Second, the loss factor for the previously transferred losses is adjusted by multiplying it by the formula for adjustment event 1.

7.50 Each of these loss factors is then adjusted by multiplying it by the formula at item 2 in Table 7.1. The formula caps the total of the loss factors for the joining group so their total does not exceed the loss factor for the group losses. This ensures the loss factors bear the correct proportion to each other. It also ensures they bear the correct proportion to the loss factors for any loss bundles already held by the acquiring group.

*Adjustment event 3 – when another loss entity joins the group*

7.51 A group's loss factors are adjusted if the group acquires another loss entity or group. Each loss factor is adjusted by multiplying it by the formula at item 3 in Table 7.1. A head company may choose to cancel the transfer of all its incoming losses to avoid this adjustment.

*Adjustment event 4 – capital injections and non-arm’s length transactions*

7.52 A group’s loss factors are adjusted if the group’s market value is increased as a result of capital injected into the group or a non-arm’s length transaction involving the group. Each loss factor is adjusted by multiplying it by the formula at item 4 in Table 7.1. See the discussion in paragraphs 7.72 to 7.76.

*Adjustment event 5 – loss factors total more than one*

7.53 A group’s loss factors are proportionally reduced if they total more than one. If they total more than one, then this incorrectly indicates that the group can generate more income than it actually does. Each loss factor is reduced by dividing it by the total loss factors. This adjustment only applies after completion of the loss factor calculation and other adjustments.

**Example 7.2**

On formation, a consolidated group calculates the following loss factors for its loss bundles:

0.193, 0.267, 0.314 and 0.412.

These loss factors total 1.186. Each loss factor is proportionally reduced so that the total of the loss factors is reduced to one:

$$0.193 \div 1.186 = 0.163$$

$$0.267 \div 1.186 = 0.225$$

$$0.314 \div 1.186 = 0.265$$

$$0.412 \div 1.186 = 0.347$$

Total	1.000
-------	-------

**More about the loss factor calculation**

*Loss factors are rounded to 3 decimal places*

7.54 Loss factors are calculated and adjusted to 3 decimal places. They are rounded up if the fourth decimal place is 5 or more.

*When will a loss factor be zero?*

*Numerator or denominator is zero*

7.55 The loss factor works out as zero if the market value of the joining entity (i.e. the numerator) is nil. Such an entity is not in an income producing position and therefore the bundle of losses transferred by it does not have a loss factor. This means the group will generally not be able to use any of the losses transferred by that entity. However, the loss bundle can achieve a positive loss factor if the entity’s value is increased under the value donor concession discussed in Chapter 8.

7.56 The loss factor is also zero if the market value of the group joined (i.e. the denominator) is nil. This reflects the fact that such a group would not be in an income producing position and therefore should not be able to use a loss.

*Loss factor would otherwise be a negative amount*

7.57 A loss factor will be zero if it would otherwise be a negative amount. This could occur in applying the formula for adjustment event 3 if the incoming loss factors were greater than one.

***Head company can choose to cancel transferred losses***

7.58 A head company can choose to cancel the transfer of a loss. A head company may do that to:

- avoid adjusting the loss factors for its existing loss bundles; or
- achieve a better outcome under adjustment event 2 which caps loss factors when both group and previously transferred losses are transferred.

7.59 A choice to cancel the transfer of a loss cannot be changed. The effect of the cancellation is as if the transfer never occurred. Cancelled losses can never be used or transferred by any entity.

## **Values used in calculating the loss factor**

***Modified market value of the joining entity***

7.60 The ***modified market value*** of a joining entity (relevant to working out the initial loss factor) is its market value, assuming:

- it has no losses and the balance of its franking account is nil;
- the subsidiary members of the group at the joining time are separate entities and not divisions or parts of the head company; and
- other corporate tax entities or loss entities in the group did not contribute directly or indirectly to the market value of the joining entity.

*Assume no tax attributes*

7.61 The market value of a joining entity is worked out as though it did not have losses or franking credits. The value is worked out as if these attributes did not exist because they do not enhance the joining entity's income generating capacity.

7.62 This means, for example, that a loss entity with no assets other than its losses will have a nil loss factor which will prevent its losses being used by the group.

*Override the single entity principle*

7.63 In working out the market value of a joining entity that is a subsidiary member, the joining entity is treated as a separate entity and not as a part of the head company.

*Assume no interests in other group members*

7.64 The market value of a joining entity is worked out as if it did not have interests in other group members. The value of a joining entity's interest in other group members is reflected in the market value of the other group members. Ignoring the value of intra-group equity prevents the double counting of that value and matches the consolidation principle that, within a consolidation group, intra-group transactions and interests are ignored.

7.65 There is one exception. A joining entity's modified market value may include value contributed by a fixed entitlement in another group member that is a trust. The inclusion of this value recognises that outside consolidation the trust's income is sheltered from income tax by the joining entity's losses. Value taken into account is so much of the trust's value that is not contributed by another member of the group, unless that member is itself a trust in which a fixed entitlement is held.

7.66 However, a joining entity's modified market value cannot include the value of a trust that:

- itself transferred losses to the head company (because the value of the trust will be counted in working out its own loss factor, though the head company could choose to cancel the transfer of losses by the trust in which case its value could be counted); or
- is a corporate unit trust or a public trading trust (because these trusts are taxed like companies as opposed to receiving flow-through treatment and so, outside consolidation, their income cannot be sheltered from income tax by a beneficiary's losses).

*Value of the joined group*

7.67 The value of the joined group at joining time is its market value ignoring any losses it has and assuming that its franking account balance is nil. The value of these attributes is ignored because they do not contribute to the group's earning capacity.

**Maintaining the integrity of the loss factor**

7.68 There will be rules to prevent the inflation of the loss factor by injections of capital into a loss entity or a consolidated group,

or through a non-arm's length transaction. This is achieved for post-consolidation events by adjustment event 4. There will also be rules for pre-consolidation events. These rules will ensure that loss factors cannot be manipulated in a way that would allow losses to be used sooner than they could have been used outside the group.

***Pre-consolidation events that increase market value***

7.69 An increase in the value of a loss entity is excluded from the entity's modified market value if the increase is as a result of either:

- an injection of capital into the loss entity, its associate or, if the loss entity is a trust, an associate of its trustee; or
- a non-arm's length transaction that involved the loss entity, its associate or, if the loss entity is a trust, an associate of its trustee.

7.70 The increase in value is the difference between the loss entity's value at the joining time and what would have been its value if the injection or transaction had not occurred. The entity's modified market value is reduced by the amount of the increase.

7.71 These rules prevent a loss entity from inflating its market value before it joins a consolidated group in order to obtain a higher loss factor. They apply to events that occur in the 4 years before the loss entity joins the group, however, they do not apply to events that occur before 9 December 2000.

***Post-consolidation events that increase market value***

7.72 A group's loss factors are adjusted if the group's market value is increased as a result of either:

- an injection of capital into the group or an associate of the group; or
- a non-arm's length transaction that involved the group or an associate of the group.

7.73 These events increase the income generating capacity of the group which reduces the proportion of income a loss entity can be regarded as generating. If these events occur, the group's loss factors are adjusted using the formula at item 4 in Table 7.1.

***What is a capital injection?***

7.74 The expression 'injection of capital' is not defined and therefore takes its ordinary meaning. Capital is generally understood as the wealth of an entity, whether in money or property. The use of the word injection conveys that the capital or wealth has been introduced from outside the

entity (or group) in the sense that it has not been obtained from the entity's (or group's) own resources.

***Exception to rules regarding events that increase market value***

7.75 However, the pre- and post-consolidation capital injection events do not apply to an injection of capital:

- into a listed public company through a dividend reinvestment scheme, provided the entity to which shares are issued held a share in the listed public company before the capital injection; or
- in association with an acquisition of shares under an employee share scheme if the scheme is one described in the rules dealing with membership of a consolidated group. (Minor holdings of shares in a company issued under certain employee share arrangements will not prevent the company being a subsidiary member of a consolidated group, see Chapter 3.)

7.76 The exceptions recognise that such schemes are unlikely to be exploited to increase loss factors. Excluding these schemes from the rules will reduce compliance costs for consolidated groups as market valuations will not need to be made as a result of operating these schemes.

**Examples of calculating and adjusting loss factors**

**Example 7.3**

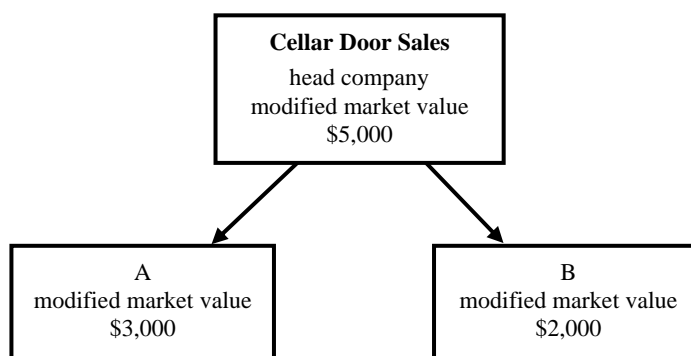

The Cellar Door Sales group consolidates. At joining time, the group's market value is \$10,000.

Loss factors for the head company's loss bundles are:

$$\text{head company: } \$5,000 \div \$10,000 = 0.5$$

$$\text{A: } \$3,000 \div \$10,000 = 0.3$$

$$\text{B: } \$2,000 \div \$10,000 = 0.2$$

### Example 7.4

Cellar Door Sales is taken over by another consolidated group, All Over Australia Liquor Distributors.

At this time, the Cellar Door Sales Group's modified market value is \$13,000 (the same as its market value). Cellar Door Sales now has a group loss in addition to its previously transferred losses.

The market value of the new group (All Over Australian Liquor Distributors and Cellar Door Sales) is \$35,000.

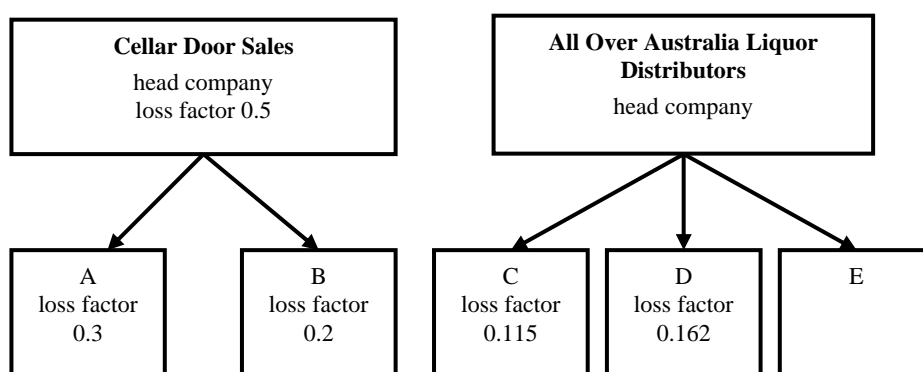

#### Cellar Door Sales

1. Calculate a loss factor for the loss bundle containing the group loss.

$$13,000 \div 35,000 = 0.371$$

2. Adjust the loss factors for the previously transferred loss bundles.

head co:	$0.5 \times (13,000 \div 35,000)$	=	0.186
A:	$0.3 \times (13,000 \div 35,000)$	=	0.111
B:	$0.2 \times (13,000 \div 35,000)$	=	<u>0.074</u>
			0.371

3. Cap the loss factors

Group loss	$0.371 \times (0.371 \div 0.742)$	=	0.186
head co:	$0.186 \times (0.371 \div 0.742)$	=	0.093
A:	$0.111 \times (0.371 \div 0.742)$	=	0.056
B:	$0.074 \times (0.371 \div 0.742)$	=	<u>0.037</u>
			0.372

Note: 0.742 is the sum of the loss factors calculated under steps 1 and 2 (i.e.  $0.371 + 0.186 + 0.111 + 0.074$ ).



### **All Over Australia Liquor Distributors**

Recalculate the loss factors for the loss bundles held by the head company of All Over Australia Liquor Distributors before the takeover.

$$\begin{array}{lcl} \text{C:} & 0.115 \times (1 - 0.372) & = 0.072 \\ \text{D:} & 0.162 \times (1 - 0.372) & = 0.102 \end{array}$$

## **Application and transitional provisions**

7.77 The consolidation regime will apply from 1 July 2002.

## **Consequential amendments**

7.78 Amendments consequential to the measures discussed in this chapter will be included in subsequent legislation.



---

# Chapter 8

## ***Transitional concessions for losses***

---

### **Outline of chapter**

8.1 This chapter explains the transitional concessions available in relation to losses transferred to a consolidated group.

### **Context of reform**

8.2 The loss factor method outlined in Chapter 7 departs from Recommendation 15.3 of *A Tax System Redesigned*. In recognition of this departure, a concessional method for the use of transferred losses has been developed to apply to certain losses transferred to a group that consolidates during the transitional period (i.e. 1 July 2002-30 June 2003).

8.3 The loss factor method sets a limit on the utilisation of losses transferred to a group by reference to the contribution to group income expected to be made by the entity that transferred the losses. A further concession is provided in recognition that, under the existing group loss transfer rules, an entity can use its losses to shelter not just its own income but also the income of another member of the same wholly-owned group. Since the group loss transfer rules will be repealed as a result of the introduction of the consolidation regime, this concession is only available to groups that consolidate during the transitional period.

### **Summary of new law**

8.4 COT losses (see paragraph 5.117) transferred to a group when it consolidates during the transitional period and that were made in an income year ending on or before 21 September 1999 are given concessional treatment. Instead of their utilisation being determined by reference to a loss factor, they may be used over 3 years.

8.5 Under an additional concession, an entity joining a consolidated group may increase its market value (for the purposes of calculating its loss factor) by a portion of the market value of another entity to which it could have transferred losses under the group loss transfer rules. This is a transitional measure that only applies if both entities joined a group at the time the group formed during the transitional period.

## Comparison of key features of new law and current law

<i>New law</i>	<i>Current law</i>
Concessional losses can be used by a head company over 3 years, subject to it having sufficient income against which those losses can be offset (and satisfying the relevant recoupment tests).	The rate of loss usage is dictated entirely by the loss entity's income or ability to transfer the loss to another member of the same wholly-owned company group (and satisfying the relevant recoupment tests).
A loss entity may add to its modified market value, the modified market value of another company to which it could have transferred losses under Division 170 of the ITAA 1997. This is for the purpose of working out the loss entity's loss factor. It may also add losses from the other company to its own loss bundle.	No equivalent. However, the rule in the new law reflects the fact that under the current law an entity may shelter its losses not just against its own income, but also against the income of another member of the same wholly-owned company group.

## Detailed explanation of new law

### Limit for using certain transferred losses

8.6 A concessional method for utilising losses is available for certain losses transferred to a consolidated group during the transitional period (i.e. concessional losses). The concession is available for losses that:

- were originally made outside the group by a company for an income year ending on or before 21 September 1999;
- are transferred to the head company of the group by that company at the time the group consolidates during the transitional period; and
- are transferred as COT losses (see paragraph 5.117).

8.7 Concessional losses may effectively be utilised by the head company over 3 years. This limit on utilisation replaces that which would otherwise apply under a loss factor.

8.8 Concessional losses must be used before other transferred losses, allowing groups the earliest possible access to the concession.

8.9 Concessional losses may only be used if the general loss rules are satisfied. For example, the rules that examine continuation of ownership or same business apply to the losses. Also, the rules that quarantine capital, foreign and film losses against income of the same type all apply to concessional losses. Further, if the general rules require the loss to be first deducted against exempt income, then the concessional loss amount must likewise be deducted first against exempt income.

8.10 The limits on utilising concessional losses are outlined in Table 8.1.

**Table 8.1: Limit on utilising concessional losses**

<i>Item</i>	<i>For this income year</i>	<i>The amount of the loss that the head company may utilise cannot exceed</i>
1	The first income year ending after the transfer time.	$\frac{1}{3}$ of the total of the amounts of the losses that were transferred to the transferee.
2	The second income year ending after the transfer time.	The difference between: (a) $\frac{2}{3}$ of the total of the amounts of the losses that were transferred to the transferee; and (b) the amount of the losses utilised for the income year mentioned in item 1.
3	The third income year ending after the transfer time, or a later income year.	The difference between: (a) the total of the amounts of the losses that were transferred to the transferee; and (b) the total of the amounts of the losses utilised for earlier income years ending after the transfer time.

8.11 The concessional method is optional. Because concessional losses must be used before other transferred losses, the choice to use the concessional method must effectively be made before any other transferred losses are used by the group. The choice is irrevocable and must be made for *all* eligible losses in a particular bundle.

8.12 The use limit imposed by the concession does not prevent the whole of a concessional loss (or its unused amount) being transferred again (i.e. to another consolidated group). However, if concessional losses are transferred again, they lose their concessional status.

8.13 For that reason, concessional losses can be said to retain a link to their loss bundle. That is, if transferred again they revert to being transferred losses subject to the loss factor limit attached to the bundle.

### **Example 8.1**

The Colossal Coal Mining Group consolidates on 1 July 2002.

At that time, a \$5,000 loss incurred in the 1998 income year is transferred to the group's head company as a COT loss. The loss is therefore eligible for concessional treatment.

The group's first income year after the eligible loss was transferred ends on 30 June 2003. But for that period the group makes a \$2,000 loss (and so is not in a position to use any of its transferred losses).

The second income year after the transfer of the eligible tax loss ends on 30 June 2004. The group has \$2,000 assessable income for that year from which it deducts its \$2,000 group loss from the previous year (because group losses must be used before concessional losses). The group's taxable income is nil so the group is still not in a position to use any of its transferred losses.

The third income year after transfer of the eligible tax loss ends on 30 June 2005. The group's assessable income less deductions (other than prior year losses) is \$10,000. The head company chooses to deduct its transferred loss using the concessional method. Because this is the third income year after the eligible loss was transferred, it may deduct the whole of the \$5,000 loss.

### **Increasing modified market value to reflect loss transferability**

8.14 A company that first transfers losses to a consolidated group (i.e. the real loss-maker) may, under certain conditions:

- achieve a higher loss factor by adding to its modified market value the modified market value of another company (the value donor) to which it could have transferred losses under the existing group loss transfer rules (i.e. in Division 170 of the ITAA 1997); and
- include in its loss bundle certain losses from the value donor's loss bundle.

#### ***Conditions***

8.15 For a company to be a value donor, it must be a company to which the real loss-maker could have transferred, under the group loss transfer rules, at least one of the losses in its bundle. Concessional losses (see paragraph 8.6) are ignored for this purpose.

8.16 To be eligible for the concession, both the real loss-maker and the value donor must be companies that join the group when it first consolidates and the group must consolidate during the transitional period.

8.17 The value donor can move certain losses from its bundle to the loss bundle of the real loss-maker. Only losses that could be transferred from the value donor to the real loss-maker under the group loss transfer rules can be moved in this way (i.e. tax losses and net capital losses). Concessional losses of the value donor cannot be moved.

***The amount of the increase***

8.18 The real loss-maker may have more than one value donor, either in relation to the same loss or in relation to different losses in its bundle. Separate increases are worked out for each loss or group of losses that meet the necessary conditions in relation to a particular value donor.

8.19 To work out the amount of the increase in the real loss-maker's modified market value, first, the proportion of the real loss-maker's losses in its bundle that are transferable to the value donor under the group loss transfer rules is worked out.

8.20 Second, that proportion is multiplied by so much of the value donor's modified market value that the head company chooses to use.

8.21 The result is the amount by which the real loss-maker's modified market value can be increased for that value donor. It is an approximation of the income of the value donor that, outside consolidation and prior to the repeal of the group loss transfer rules, the companies could have chosen to have sheltered by the real loss-maker's losses.

***What is the value donor's modified market value?***

8.22 The value donor's modified market value is worked out by applying the same rules that a joining entity uses as part of its loss factor calculation. This includes the rules that reduce modified market value for certain capital injections or non-arm's length transactions that increased the market value of an entity in the period prior to consolidation. This ensures that the capital injection rules are not avoided by capital being injected into a value donor and the real loss-maker increasing its loss factor to reflect those injections by use of the value donor rules.

8.23 The value donor's modified market value remaining to be used in determining the loss factor for the losses remaining in its loss bundle, is its modified market value reduced by each amount of that value that has been used in calculating another entity's loss factor.

8.24 An entity may be the value donor of more than one real loss-maker. The total of the amounts chosen to be used by the head company in working out increases for each of those real loss-makers cannot exceed the modified market value of the value donor.

### Example 8.2

A wholly-owned group consists of a head company, H Co, and 2 subsidiary companies. The group consolidates on 1 July 2002. At that time, the market value of the group is \$10,000.

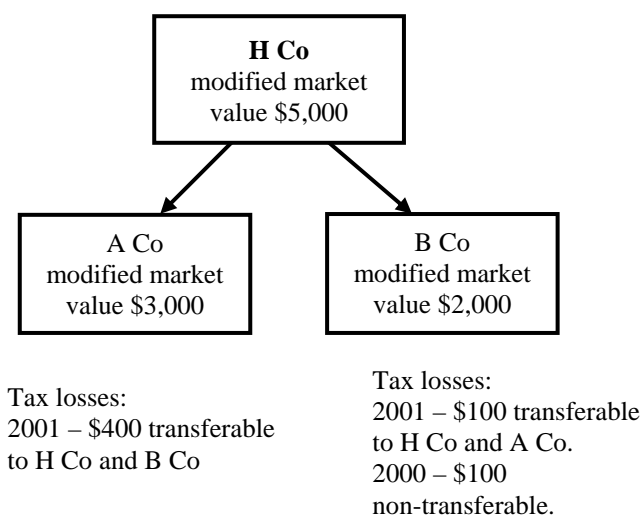

In the absence of the value donor concession, the loss factors of A Co and B Co would be 0.3 and 0.2 respectively. Under the concession, losses and value can be transferred *either* to A Co or B Co.

#### Transfer to A Co

A Co's only loss is transferable to H Co, so A Co can add H Co's modified market value when calculating its loss factor.

A Co's loss is also transferable to B Co, so A Co can add B Co's modified market value to its own when calculating its loss factor. Assume only 50% of B Co's value is chosen to be added. This would allow some value to remain with B Co to be used in determining a loss factor to allow utilisation of B Co's non-transferable loss.

Therefore, A Co's loss factor is now calculated as follows:

$$(\$3,000 + \$5,000 + (50\% \times \$2,000)) \div \$10,000 = 0.9$$

B Co's transferable loss of \$100 is moved to A Co's bundle.

B Co's loss factor for its bundle consisting of the \$100 non-transferable loss is calculated as follows:

$$(\$2,000 - (50\% \times \$2,000)) \div \$10,000 = 0.1$$



### **Transfer to B Co**

B Co has a loss that is transferable to H Co, so B Co can add a portion of H Co's modified market value when calculating its loss factor. That portion is determined based on the amount of B Co's losses that are transferable to H Co as a proportion of B Co's total losses.

$$\$5,000 \times (100 / 200) = \$2,500$$

B Co also has a loss that is transferable to A Co, so B Co can add a portion of A Co's modified market value to its own when calculating its loss factor. The amount that can be added is calculated as follows:

$$\$3,000 \times (100 / 200) = \$1,500$$

A Co's transferable loss would be moved to B Co's bundle. B Co's loss factor would be calculated as follows:

$$(\$2,000 + \$2,500 + \$1,500) \div \$10,000 = 0.6$$

A Co now does not have a loss bundle as its only loss was moved to B Co's bundle.

## **Application and transitional provisions**

8.25 The measures discussed in this chapter will apply to certain losses transferred to a group that consolidates during the transitional period (i.e. 1 July 2002 to 30 June 2003).

## **Consequential amendments**

8.26 Amendments consequential to the measures discussed in this chapter will be included in subsequent legislation.



---

# **Chapter 9**

## ***Franking accounts in consolidated groups***

---

### **Outline of chapter**

9.1 Part 1 of Schedule 1 to this exposure draft provides for the treatment of franking accounts in consolidated groups. Briefly, this exposure draft deals with the treatment of the existing balance of franking accounts of subsidiary members upon entry into a consolidated group, and also with the operation of the head company's franking account during the period of consolidation.

9.2 At a later stage, the existing anti-avoidance measures in the ITAA 1936 aimed at preventing franking credit trading (including the franking rules that relate to exempting companies and former exempting companies) will be extended to accommodate consolidated groups. In particular, these measures will address specific areas relating to franking benefit holding requirements and franking credit trading as they apply in relation to entities joining a consolidated group.

9.3 This exposure draft is based on the draft provisions for the system which were included in the exposure draft for the New Business Tax System (Entity Taxation) Bill 2000. It is proposed that the new imputation system will apply from 1 July 2002.

### **Context of reform**

9.4 As part of the introduction of the consolidation regime, *A Tax System Redesigned* recommended that a consolidated group operate a single franking account at the head company level and that all the existing franking credits of members of the group be pooled.

9.5 The proposed franking account rules for consolidated groups provide for the pooling of franking credits. The provisions also set out special rules for the operation of the franking accounts of both the head company and of subsidiary members of a consolidated group during the period of consolidation.

### **Summary of new law**

9.6 In essence, a subsidiary member will have a dormant franking account during the period in which it is a member of a consolidated group. At the time at which it joins a consolidated group, any surplus in its

franking account is transferred to the head company's franking account and similarly, any deficit in the subsidiary member's franking account creates a liability to pay franking deficit tax.

9.7 Any franking credits or debits that would otherwise have arisen in the franking account of the subsidiary member (i.e. were it not a member of a consolidated group with a dormant account) are attributed to the franking account of the head company. This is what is meant by a dormant franking account.

9.8 The rules also deal with the franking of distributions by a subsidiary member of a consolidated group to shareholders (and in some cases, other entities) because those shareholders hold certain shares known as disregarded ESAS shares (as discussed in Chapter 3). These shares are disregarded for the purpose of eligibility for membership of a consolidated group.

### **Comparison of key features of new law and current law**

<i>New law</i>	<i>Current law</i>
Subsidiary members of a consolidated group have a dormant franking account during the period of consolidation.	Subsidiary members of wholly-owned groups operate an active franking account in their own right.
Franking credits and debits, which would otherwise arise in a subsidiary member's franking account, are attributed to the head company's franking account.	Franking credits and debits arise in the subsidiary's own account in accordance with its treatment as a separate taxpaying entity.
Franking deficit tax is payable by the entity at the end of the income year and upon entry, as a subsidiary member, to a consolidated group if its franking account is in deficit at that time. No franking deficit tax is payable by the entity during the period in which it is a subsidiary member of a consolidated group.	Franking deficit tax is payable at the end of a franking year if the franking account is in deficit at that time.
A subsidiary member cannot frank distributions. Distributions made by subsidiary members on ESAS shares are taken to be distributions by the head company.	A subsidiary may frank frankable distributions to its members in accordance with the current imputation rules.

## Detailed explanation of new law

9.9 The franking account rules in consolidation can be divided into 4 distinct headings:

- treatment of any surplus or deficit in a subsidiary's franking account upon joining a consolidated group;
- treatment of a subsidiary's franking account during consolidation;
- treatment of the head company's franking account during consolidation; and
- treatment of distributions by a subsidiary member during consolidation.

### Treatment of franking surplus or deficit on entry into consolidation

9.10 When an entity becomes a subsidiary member of a consolidated group, it must determine its franking account balance at the time of entry. The joining entity must transfer any *surplus* in its franking account at the joining time (the time at which the joining entity becomes a member of a consolidated group) to the franking account of the head company. In this manner, franking credits are pooled in the franking account of the head company. [Schedule 1, item 1, section 709-75]

9.11 When any surplus is transferred to the head company's franking account, an equivalent *debit* arises in the joining entity's franking account. This creates a nil balance in the account of the joining entity. A corresponding *credit* arises in the head company's franking account. [Schedule 1, item 1, subsection 709-60(2)]

9.12 If the subsidiary has a *deficit* in its franking account just prior to entry into a consolidated group, it is liable to pay franking deficit tax on the basis of its franking account balance as at the joining time. [Schedule 1, item 1, subsection 709-60(3)]

9.13 The liability to pay franking deficit tax gives rise to a credit in the joining entity's franking account just after the joining time. It is necessary to record this credit in the otherwise dormant subsidiary account so that this account then has a nil balance during the period of consolidation.

### Treatment of subsidiary's franking account during consolidation

9.14 During the period in which a subsidiary entity is a member of a consolidated group, its franking account is dormant or inactive. This means that in general, neither credits nor debits can arise in that account, although the account still exists. [Schedule 1, item 1, section 709-65]

9.15 Initially however, where a subsidiary member has a franking account surplus immediately before the joining time, a debit will arise at the joining time to create a nil balance in the franking account of the subsidiary member.

9.16 A credit will arise just after the joining time in the subsidiary member's otherwise dormant account if that member becomes liable to make a payment of franking deficit tax.

## **Treatment of head company's franking account during consolidation**

### ***General rule***

9.17 The rules for franking accounts are intended to facilitate the operation of imputation rules in accordance with the single entity principle. That is, once a subsidiary entity has become a member of a consolidated group, the provisions of the tax law which concern imputation and franking accounts will operate as if the consolidated group is a single entity.

9.18 To this end, the imputation rules ensure that the head company is responsible for operating the single franking account and that events which would affect a subsidiary are instead attributed to the head company. Therefore, activities which would otherwise have caused a franking credit or debit to arise in the franking account of a subsidiary member will instead give rise to a franking credit or franking debit in the franking account of the head company subject to any special rules.  
*[Schedule 1, item 1, sections 709-70 and 80]*

9.19 This rule does not however, include a franking credit that arises in a subsidiary's franking account after it joins a consolidated group, because of a liability to pay franking deficit tax at the joining time.

### **Example 9.1**

While it is a member of a consolidated group, a subsidiary member receives a refund of income tax in relation to an assessment of income tax relating to a period prior to when the member joined the consolidated group. In the ordinary course and outside of consolidation, this would lead to a debit arising in the franking account of the subsidiary.

However, given that the subsidiary's franking account is dormant, the debit will arise in the head company's franking account. This is the case even though the assessment relates to a pre-consolidation period.

9.20 Other credits and debits will arise in the head company's franking account in the ordinary course of its usual activities as a taxpayer and a franking entity. For example, the payment of income tax will generate franking credits in the head company's franking account and similarly, the franking of dividends will generate franking debits.

### ***Other credits or debits as a result of consolidation***

9.21 As mentioned in paragraph 9.11, any franking surplus in the subsidiary member's franking account immediately before joining time will give rise to a franking credit in the head company's franking account at the time of consolidation.

### **Treatment of distributions made by a subsidiary during consolidation**

9.22 The general rule in consolidated groups is that a subsidiary member cannot frank distributions to entities outside the group. Only the head company of the group may allocate franking credits to frankable distributions by a subsidiary member while it is a member of that group. *[Schedule 1, item 1, section 709-90]*

### ***Distributions made under ESAS shares held by a subsidiary member***

9.23 Certain shares held in a subsidiary member are able to be disregarded when determining whether that subsidiary member is a '100% Australian subsidiary' of the head company and therefore eligible to be a member of a consolidated group. These are ESAS shares.

9.24 For the purpose of distributions made by a subsidiary in relation to disregarded ESAS shares, a frankable distribution made by a subsidiary member will be treated as a frankable distribution by the head company to a member of the head company for the purposes of the imputation rules. This means that the imputation and franking consequences flowing from those rules will apply in respect of the distributions made by the subsidiary. *[Schedule 1, item 1, section 709-95]*

### **Application and transitional provisions**

9.25 These provisions will come into effect on 1 July 2002, along with the other aspects of the consolidation measures.

### **Consequential amendments**

9.26 Amendments consequential to the measures in this chapter will be included in subsequent legislation.





---

## **Chapter 10**

# ***Resident wholly-owned subsidiaries of a common foreign holding company***

---

### **Outline of chapter**

10.1 This chapter provides for certain resident wholly-owned subsidiaries of a foreign company to be treated as a consolidated group (MEC groups) for income tax purposes.

### **Context of reform**

10.2 Under the membership rules for consolidated groups contained in Chapter 3, a consolidatable group consists of a single resident head company and all the resident wholly-owned subsidiaries of the head company. Without this measure, wholly-owned resident subsidiaries of a foreign resident company would not be able to form a consolidated group in the absence of a resident head company unless they were restructured. The underlying rationale of this measure is to ensure that existing company groups that currently have access to grouping provisions (e.g. loss transfer and CGT rollover) will be able to form a consolidated group despite not having a single resident head company.

### **Summary of new law**

#### **MEC group treated as a consolidated group**

10.3 A MEC group is treated as a consolidated group for income tax purposes. This means that the MEC group will be treated as a single entity in relation to the income tax obligations of its member entities.

#### **Formation and membership of a MEC group**

10.4 A MEC group is formed by 2 or more eligible tier-1 companies making an irrevocable choice to consolidate a potential MEC group. Broadly, an eligible tier-1 company is a company that is the first level of investment in Australia by a foreign resident company. Each of the eligible tier-1 companies making the choice must be wholly-owned subsidiaries of the same non-resident holding company (the top company) on the day the choice takes effect. The eligible tier-1 companies must identify the top company and jointly nominate one of themselves to be the

provisional head company of the MEC group. An eligible tier-1 company can only be a provisional head company if all its membership interests are held by entities that are not members of the potential MEC group.

10.5 A MEC group can also be formed as a result of an ordinary consolidated group converting to a MEC group. This will occur when the head company of the consolidated group is also an eligible tier-1 company of a top company and subsequently another company becomes an eligible tier-1 company of the same top company.

10.6 The members of a MEC group comprise all the eligible tier-1 companies of a top company and all the resident entities that are wholly-owned subsidiaries of those eligible tier-1 companies. Subsidiaries that are wholly-owned by 2 or more eligible tier-1 companies are also members of a MEC group.

10.7 Once formed, a MEC group will continue to exist until either the potential MEC group ceases to exist or the group ceases to have a provisional head company.

10.8 The provisional head company of the MEC group at the end of an income year is treated as the head company of the MEC group for that part of the income year in which the group was in existence. Accordingly, where the MEC group existed throughout the income year, the provisional head company will be treated as the head company from the beginning of the income year – even where the company was only appointed as the provisional head company part way through the income year.

10.9 The head company is responsible for the final income tax obligations of the group for the year and will hold the losses, franking credits and other tax attributes of the MEC group.

### **Treatment of assets held by group members**

10.10 Under the single entity rule, the head company of a MEC group will be taken to have purchased each of the assets held by subsidiary members of the group at the time those entities become members of the group. Broadly, the head company's cost of acquiring the assets held by eligible tier-1 companies will be an amount equal to their existing values for tax purposes. This is akin to the treatment of assets held by the head company of a consolidated group.

10.11 The head company of a MEC group's cost of acquiring the assets held by subsidiary members of the MEC group, other than eligible tier-1 companies, will be worked out in the same manner as for an entity that becomes a subsidiary member of a consolidated group.

## **Treatment of membership interests not held by group members**

10.12 The cost bases of all membership interests in eligible tier-1 companies of a MEC group that are held by entities that are not members of the group are to be pooled just before the time certain events called trigger events occur. A trigger event will occur if:

- an eligible tier-1 company ceases to be a member of the MEC group; or
- a CGT event happens to a membership interest in an eligible tier-1 company that is held by an entity that is not a member of the MEC group.

10.13 Pooling of the cost bases of these interests is required because the original cost base of the membership interests may be inappropriate as a result of assets being freely transferred between group members since the time the group came into existence. Pooling facilitates the free transfer of assets within a MEC group by removing the need to make value shifting adjustments to the membership interests each time there is a transfer of value between MEC group members.

10.14 At the time a trigger event occurs, the membership interests held by entities that are not members of the group will be re-allocated a cost based on an allocation from the pool. The percentage allocation from the pool will equal the market value of the membership interest as a proportion of the market value of all membership interests in eligible tier-1 companies that are held by non-group members.

## **Distributions made by eligible tier-1 companies**

10.15 Distributions made by eligible tier-1 companies of the MEC group will be taken to be made by the head company of the group. This treatment is required because the head company is the only member of the group that can frank distributions.

## **Change in provisional head company**

10.16 A MEC group continues to exist following a provisional head company of the group ceasing to satisfy the conditions for being a provisional head company provided another eligible tier-1 company in the group is appointed as a replacement provisional head company within a specified period of time.

## **Transfer of tax attributes to new provisional head company**

10.17 If an eligible tier-1 company is appointed as a replacement provisional head company, all of the tax attributes (e.g. losses and franking credits) of the group will be transferred from the old provisional head company to the new provisional head company. The transfer of tax

attributes will produce a tax-neutral outcome irrespective of which eligible tier-1 company is appointed as the new provisional head company.

### **Imposing an income tax liability on the head company of a MEC group**

10.18 Separate Imposition Acts will be introduced for the purpose of imposing, on the head company of a MEC group, any liability arising as a result of the operation of the single entity rule.

### **Comparison of key features of new law and current law**

<i>New law</i>	<i>Current law</i>
A MEC group is treated as a consolidated group and taxed as a single entity.	Each entity in a wholly-owned group is taxed as a separate entity.
Broadly, the cost bases of all membership interests in eligible tier-1 companies who are members of a MEC group, other than those interests held by group members, are to be pooled just before consolidation. A new purchase price for the interest in an eligible tier-1 company is worked out based on an allocation from the pool when: <ul style="list-style-type: none"> <li>• the eligible tier-1 company leaves the group; or</li> <li>• a CGT event happens to a membership interest in the eligible tier-1 company.</li> </ul>	A separate cost base is maintained for each membership interest based on the original purchase price of the interest.
The head company of the MEC group will maintain the franking account for the group. Eligible tier-1 companies, who are members of the MEC group, are able to access the pool of franking credits held by the head company of the group to allow distributions to be franked.	Each company maintains its own franking account.

### **Detailed explanation of new law**

#### **Formation and membership of a MEC group**

##### *How does a MEC group come into existence?*

10.19 A MEC group can be formed in one of 2 ways – firstly as a result of a choice being made to form the group and secondly as a result of a consolidated group converting to a MEC group. [*Schedule 1, item 1, subsection 719-10(1)*]

*Choosing to form a MEC group*

10.20 A MEC group is formed as a result of all the eligible tier-1 companies in a potential MEC group jointly signing a notice informing the Commissioner of their choice to consolidate the group. The eligible tier-1 companies must specify a day in the notice as the day from which the group will begin to exist. Once formed, a MEC group will continue to exist until either:

- the potential MEC group ceases to exist; or
- there is no longer a provisional head company of the group.

*[Schedule 1, item 1, paragraph 719-10(1)(a) and subsection 719-10(2)]*

10.21 What constitutes an eligible tier-1 company and a potential MEC group is discussed in paragraphs 10.52 to 10.56 and 10.30 to 10.40 respectively.

10.22 Where a company ceases to be the provisional head company of a MEC group, a replacement provisional head company must be appointed by the remaining eligible tier-1 companies in the group. Notification of the replacement provisional head company must be given to the Commissioner within a specified period of time – the duration of which is still being considered. Failure to appoint a replacement within this period will result in the MEC group ceasing to exist.

10.23 If a replacement company is appointed, the appointment will take effect from the time that the previous provisional head company ceased to qualify as the provisional head company. A change in provisional head company of a MEC group will therefore not affect the continuation of the group provided a replacement is appointed within the specified period. The qualifications for being a provisional head company are discussed in paragraphs 10.59 to 10.63.

*Consolidated group becoming a MEC group*

10.24 A MEC group is also formed when a consolidated group converts to a MEC group. This will happen if the head company of a consolidated group is an eligible tier-1 company of a top company at a particular time and after that time another company becomes an eligible tier-1 company of the same top company. It is not necessary that the other company be the head company of a consolidated group for a MEC group to form in these circumstances. *[Schedule 1, item 1, paragraph 719-10(1)(b)]*

10.25 However, a MEC group will only form in these circumstances if the head company of the consolidated group meets the qualifications for being a provisional head company of a MEC group. If the qualifications are not met, the company will continue to be a head company of a consolidated group and the MEC group will be taken not to have formed.

10.26 The conversion of a consolidated group to a MEC group, is referred to as a *special conversion event*. The conversion to a MEC group will be automatic and no choice will be required to be made or given to the Commissioner. Converting the consolidated group to a MEC group ensures the ‘all in’ principle underlying consolidation is given effect. [Schedule 1, item 1, section 719-60]

**Example 10.1**

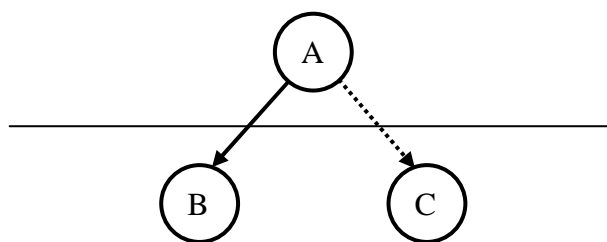

A Co is a foreign resident company with a wholly-owned Australian resident subsidiary B Co who is the head company of a consolidated group. A Co subsequently acquires 100% of the membership interests in another Australian resident company, C Co, who becomes an eligible tier-1 company of the same top company, A Co. This triggers a special conversion event and the consolidated group will convert to a MEC group. B Co will be the provisional head company of the MEC group.

*MEC group becoming a consolidated group*

10.27 A MEC group may also convert to a consolidated group in some circumstances – a full discussion on when a MEC group may become a consolidated group is contained in paragraphs 3.13 and 3.14.

*MEC group and consolidated group to be mutually exclusive*

10.28 A choice made by an eligible tier-1 company to form a consolidated group will not have effect if it is a member of a potential MEC group and there is at least one other eligible tier-1 company that is a member of the same potential MEC group. Chapter 3 contains a full discussion on when a choice to form a consolidated group will have effect.

**Membership of a MEC group**

10.29 The members of a MEC group at any time will comprise the members of the potential MEC group at that time. The membership of a potential MEC group is discussed in paragraphs 10.30 to 10.40. One of the members of the MEC group who is an eligible tier-1 company will be taken to be the head company of the MEC group. The remaining members of the MEC group will be treated as *subsidiary members* of the group. Which eligible tier-1 company is taken to be the head company of the group is discussed in paragraphs 10.59 to 10.63. [Schedule 1, item 1, subsection 719-10(3) and section 719-47]

### ***What is a potential MEC group?***

10.30 Identifying who are members of a potential MEC group is important as the membership of a MEC group at a particular time will comprise all the members of the potential MEC group at that time. Membership of a potential MEC group consists of:

- those entities who qualify under what is called for the purposes of this explanatory material the *standard membership tests*; and
- those entities who qualify under what is called for the purposes of this explanatory material the *interposed foreign resident entity tests*.

#### *Standard membership tests*

10.31 The following entities will qualify to be members of a potential MEC group under the standard membership tests:

- all the eligible tier-1 companies of a top company;
- all the companies who are wholly-owned subsidiaries of an eligible tier-1 company of a top company and which:
  - are an Australian resident company, but not a prescribed dual resident; and
  - meet the income tax treatment requirements discussed in paragraphs 3.29 to 3.40 for being a member of a consolidated group;
- all the trusts who are wholly-owned subsidiaries of an eligible tier-1 company and which:
  - meet the Australian residency requirements discussed in paragraphs 3.58 and 3.59 – a trust that meets these requirements is referred to in the remainder of this chapter as a resident trust; and
  - meet the income tax treatment requirements discussed in paragraphs 3.50 to 3.54 for being a member of a consolidated group; and
- all the partnerships who are wholly-owned subsidiaries of an eligible tier-1 company of a top company.

*[Schedule 1, subsection 719-30(1)]*

10.32 For the purpose of determining whether an entity is a wholly-owned subsidiary of an eligible tier-1 company, it is to be assumed that all the membership interests that are beneficially held by eligible tier-1 companies are held by a single eligible tier-1 company. *[Schedule 1, item 1, subsection 719-30(1), column 3 in the table]*

10.33 An entity will only qualify to be a member of a potential MEC group under the standard membership tests if each entity interposed between the eligible tier-1 company and the entity being tested are also members of the potential MEC group or, alternatively, hold membership interests only as a nominee of one or more entities each of which is a member of the potential MEC group. *[Schedule 1, item 1, subsection 719-30(2)]*

10.34 Allowing an entity to be interposed who is not a member of the group could result in inappropriate capital gains and losses arising upon a subsequent disposal of membership and debt interest in the entity. The gains and losses could arise because value shifting adjustments would not be made to those interests if value was shifted between other members of the potential MEC group.

*Interposed foreign resident entity tests*

10.35 The interposed entity requirements outlined in paragraph 10.33 are relaxed in a specific set of circumstances to allow certain resident companies, trusts and partnerships to become members of the potential MEC group despite one or more foreign resident entities being interposed between the resident entities and an eligible tier-1 company of the top company.

10.36 The interposed foreign resident entity tests are designed to allow resident entities to become members of a potential MEC group without requiring the group to restructure in order for the entities to qualify under the standard membership tests.

10.37 Different tests apply under the interposed foreign resident entity tests depending on whether the entity is a company or a trust or partnership. A company will qualify as a member of a potential MEC group under these tests if:

- there is at least one entity interposed between the company and an eligible tier-1 company of a top company that is either:
  - a foreign resident company; or
  - a trust that does not meet the residency requirements set out in paragraph 3.59 – a trust that does not meet these requirements is referred to in the remainder of this chapter as a non-resident trust;
- each entity interposed between the company and an eligible tier-1 company of the top company is either:



- an entity that qualifies as a member of the potential MEC group under either the standard membership tests or the interposed foreign resident entity tests;
  - a foreign resident company;
  - a non-resident trust;
  - an entity that holds membership interests only as a nominee of one or more of the previously mentioned entities; or
  - a partnership, where each partner is a foreign resident company or a non-resident trust; and
- the company would qualify under the standard membership tests if it was assumed that each of the following interposed entities was a member of the potential MEC group:
    - each interposed entity that is a foreign resident company; and
    - each interposed entity that is a non-resident trust.

*[Schedule 1, item 1, subsection 719-30(3)]*

10.38 A trust or partnership will qualify as a member of a potential MEC group under the interposed foreign resident entity tests if it would qualify under the standard membership tests if it was assumed that each company that satisfied the interposed foreign resident entity tests were also an eligible tier-1 company of the top company. *[Schedule 1, item 1, subsection 719-30(4)]*

10.39 The interposed foreign resident entity tests effectively allow the interposed foreign resident entities to be disregarded for the purposes of determining who is a member of a potential MEC group. The foreign resident entities will not themselves become members of the potential MEC group under the interposed foreign resident entity tests. Example 10.2 illustrates further which entities qualify as members of a potential MEC group under these tests.

#### Value shifting adjustments

10.40 A condition of an entity becoming a member of a potential MEC group under the interposed foreign resident entity tests is that appropriate value shifting adjustments be made to ensure artificial capital losses cannot arise upon a subsequent disposal of membership and debt interests in the interposed foreign resident entities. Artificial losses could arise because value shifting adjustments would not be made to those interests if value was shifted from a group member who satisfies the interposed foreign resident entity tests to another group member who satisfies the

standard membership tests. Details of the adjustments to be made are still being developed.

**Example 10.2**

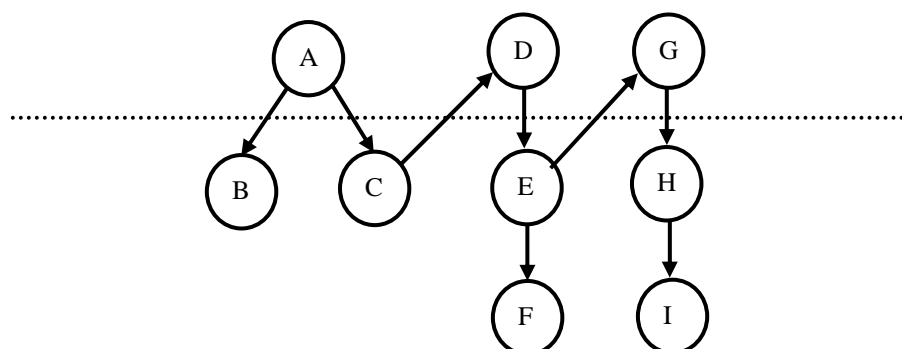

Assume B Co and C Co are eligible tier-1 companies of a top company, A Co. C Co holds all the membership interests in a foreign resident company, D Co. D Co has 2 wholly-owned Australian resident subsidiaries, an Australian resident company, E Co, and a resident trust, F. E Co also holds all the membership interests in another foreign resident company, G Co. G Co has 2 wholly-owned Australian resident subsidiaries, a resident trust, H, and an Australian resident company, I Co.

B Co and C Co will qualify as members of the potential MEC group under the standard membership tests. E Co will qualify as a member of the potential MEC group under the interposed foreign resident entity tests because there is only one entity interposed between it and the eligible tier-1 company of the top company and that entity is a foreign resident company. Trust F will also qualify as a member under the interposed foreign resident entity tests as it would satisfy the standard membership tests if it was assumed that E Co was also an eligible tier-1 company.

Trust H will not satisfy either the standard membership tests or the interposed foreign resident entity tests. Trust H cannot be a member of the group because, as intra-group transactions within a MEC group are ignored, it would not be possible to calculate the net income of the trust for the purpose of assessing the beneficiary, G Co, who would not be a member of the group.

I Co will also not satisfy either the standard membership tests or the interposed foreign resident entity tests. I Co cannot be a member of the group as there is a resident entity, trust H, interposed between it and an eligible tier-1 company of the top company who is not a member of the group. Whilst the interposed foreign resident entity tests allow certain entities to be interposed that are not members of the group, each of those entities must be foreign resident entities.

If Trust H was instead a company, both H Co and I Co would be members of the potential MEC group under the interposed foreign resident entity rules.

Appropriate value shifting adjustments will be required to be made to C Co's interest in D Co. The adjustments are required because no adjustments will be made if value is subsequently shifted from E Co to C Co because of the operation of the single entity rule. The value shifting adjustments will ensure inappropriate capital losses do not arise upon a subsequent disposal of the membership and debt interests in D Co.

***What is a wholly-owned subsidiary?***

10.41 An entity is a *wholly-owned subsidiary* of another entity if all the membership interests in the subsidiary entity are beneficially owned by the holding entity or a wholly-owned subsidiary of the holding entity or any combination of the holding entity and its wholly-owned subsidiaries. Paragraphs 3.61 to 3.66 contain a full discussion on when an entity will be a wholly-owned subsidiary of another entity.

10.42 In determining whether an entity is a wholly-owned subsidiary, certain employee shares are allowed to be held in a company without affecting the wholly-owned status of the company. Special rules also apply to ensure that an entity that is held through a non-fixed trust is not prevented from being treated as a wholly-owned subsidiary. The rules relating to employee shares and non-fixed trusts are discussed in paragraphs 3.68 to 3.76. [*Schedule 1, item 1, sections 719-50 and 719-55*]

***What is a top company?***

10.43 The top company is the reference point from which all Australian resident wholly-owned subsidiaries are identified. It is these wholly-owned subsidiaries that may become members of a potential MEC group.

10.44 A *top company* must be a foreign resident company and, in general, must not be a wholly-owned subsidiary of another company. This ensures the 'all in' principle is given its widest possible application. [*Schedule 1, item 1, paragraph 719-45(1)(a)*]

10.45 A top company may be a wholly-owned subsidiary of a foreign resident trust even where that trust has a wholly-owned Australian resident subsidiary. The foreign trust is not used as the reference point for applying the 'all in' principle in these circumstances because any wholly-owned Australian resident subsidiary of the trust would not currently be able to access grouping benefits with any wholly-owned Australian resident subsidiaries of the foreign resident company.

10.46 A company will still qualify as a top company if it is a wholly-owned subsidiary of an Australian resident company:

- that is a prescribed dual resident;

- that is of a type which is specifically excluded from being a member of a consolidated group – paragraph 3.36 contains a list of these types of companies; or
- where no part of its taxable income (if any) would be taxable at a rate that is or equals the general company tax rate.

*[Schedule 1, item 1, subsection 719-45(1), column 4 of item 1 in the table]*

10.47 A foreign resident company will not qualify as a top company if it is a wholly-owned subsidiary of an Australian resident company that does not satisfy any of the 3 tests listed in paragraph 10.46. This is because wholly-owned Australian resident subsidiaries of the foreign resident company will qualify as subsidiary members of a consolidated group or a consolidatable group under the rules discussed in paragraphs 3.77 to 3.85 – those rules being the equivalent tests for consolidated groups to the interposed foreign resident entity tests discussed in paragraphs 10.35 to 10.39. Example 10.3 illustrates the operation of those rules.

### Example 10.3

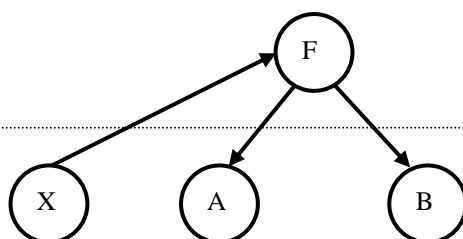

Assume that A Co and B Co are both Australian resident companies and wholly-owned subsidiaries of a foreign resident company F Co. In general, F Co will not qualify as a top company as it is a wholly-owned subsidiary of another company X Co. However, F Co will qualify as a top company if X Co is, for example, a company of a type which is specifically excluded from being a member of a consolidated group.

X Co cannot qualify as a top company as it is an Australian resident company. If X Co satisfies the tests for being a head company of a consolidated group, A Co and B Co may qualify as subsidiary members of a consolidated group under the rules discussed in paragraphs 3.77 to 3.85 – those rules being the equivalent tests for consolidated groups to the interposed foreign resident entity tests discussed in paragraphs 10.35 to 10.39.

### *What is a tier-1 company?*

10.48 All the eligible tier-1 companies of a top company qualify as members of a potential MEC group under the standard membership tests. The first step in identifying whether a company is an eligible tier-1 company is determining whether the company meets the tests for being a tier-1 company.

10.49 A company will be a *tier-1 company* if:

- it is a wholly-owned subsidiary of a top company;
- it is an Australian resident and not a prescribed dual resident;
- it has all or some of its taxable income (if any) taxed at a rate that is or equals the general company tax rate;
- it is not a company of a type which is specifically excluded from being a member of a consolidated group – paragraph 3.37 contains a list of these types of companies; and
- it must not be a wholly-owned subsidiary of a company that is an Australian resident other than one:
  - that is a prescribed dual resident;
  - that is of a type which is specifically excluded from being a member of a consolidated group – paragraph 3.37 contains a list of these types of companies; or
  - where no part of its taxable income (if any) would be taxable at a rate that is or equals the general company tax rate.

*[Schedule 1, item 1, paragraph 719-45(1)(b)]*

10.50 Because tier-1 companies are potentially capable of becoming the head company of a MEC group, the category of entities who qualify as tier-1 entities is restricted to companies. This is consistent with the membership rules for consolidated groups which allow only companies to be head entities of a group. Chapter 3 contains more details on why only companies can be the head entity of a group.

10.51 In applying the tests for determining whether an entity is a tier-1 company, special rules will apply to treat certain companies as wholly-owned subsidiaries of another Australian resident company in some circumstances. Example 10.4 illustrates the operation of those rules. *[Schedule 1, item 1, subsection 719-45(2)]*

**Example 10.4**

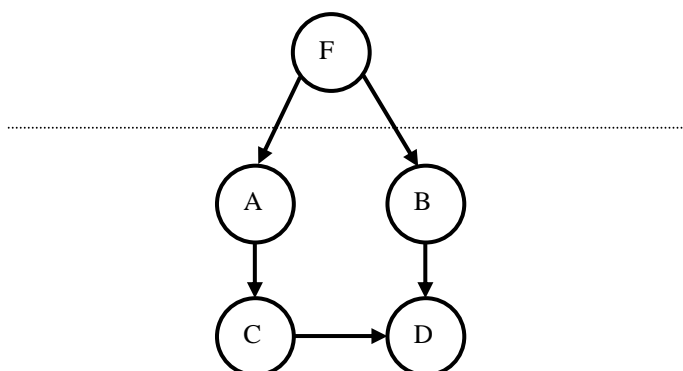

Assume that A Co, B Co, C Co and D Co are all Australian resident companies. F Co is the top company. A Co, B Co and D Co could all potentially be tier-1 companies as none of them is a wholly-owned subsidiary of another Australian resident company. Despite this, special rules will apply to treat D Co as a wholly-owned subsidiary of another Australian resident company if B Co and either A Co or C Co satisfy the tests for being a tier-1 company.

***What is an eligible tier-1 company?***

10.52 Only those tier-1 companies that qualify as eligible tier-1 companies can become members of a potential MEC group. Allowing all tier-1 companies to become members of a potential MEC group could result in inappropriate capital gains and losses arising upon a subsequent disposal of membership and debt interests in certain entities that are interposed between 2 tier-1 companies. The gains and losses could arise because value shifting adjustments would not be made to those interests if value was shifted between other members of the potential MEC group.

*[Schedule 1, item 1, subsection 719-40(1)]*

10.53 A tier-1 company will not qualify as an *eligible tier-1 company* if:

- there is at least one entity interposed between it and the top company which meets one of the tests listed in paragraph 10.54; and
- one of the following entities holds a membership interest in that particular interposed entity:
  - another tier-1 company of a top company;
  - a wholly-owned subsidiary of another tier-1 company of a top company; or
  - an entity that holds membership interests only as a nominee of one or more of the previously mentioned entities.

*[Schedule 1, item 1, subsection 719-40(2) and paragraph 719-40(3)(c)]*

10.54 An interposed entity will only disqualify a tier-1 company from being an eligible tier-1 company if it meets one of the following tests:

- it is a company that is a foreign resident;
- it is a company that is a prescribed dual resident;
- it is a non-resident trust;
- it is a resident trust that is not a wholly-owned subsidiary of another tier-1 company of the top company;

- it is an entity of a type which is specifically excluded from being a member of a consolidated group – paragraph 3.37 contains a list of these types of companies; or
- it is a company that is an Australian resident where no part of its taxable income (if any) would be taxable at a rate that is or equals the general company tax rate.

[Schedule 1, item 1, paragraph 719-40(3)(a)]

10.55 An interposed entity that meets one of the tests in paragraph 10.54 will not disqualify a tier-1 company from being an eligible tier-1 company if the entity only holds membership interests as a nominee of one or more entities each of which is:

- another tier-1 company of the top company; or
- an entity that is a wholly-owned subsidiary of another tier-1 company of a top company.

[Schedule 1, item 1, paragraph 719-40(3)(b)]

10.56 In working out whether a tier-1 company meets the tests for being an eligible tier-1 company, several of the tests require ascertaining whether a particular entity is a wholly-owned subsidiary of another tier-1 company of the top company. In applying those tests, it is to be assumed that all the membership interests that are beneficially owned by tier-1 companies of the top company were owned by a single tier-1 company of the top company. [Schedule 1, item 1, subsection 719-40(4)]

### Example 10.5

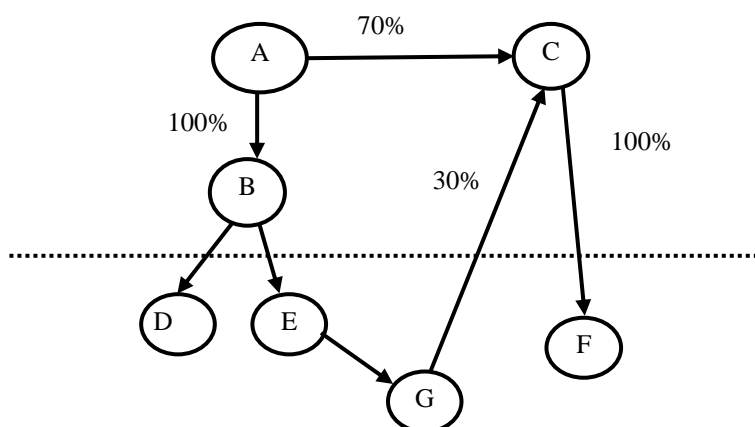

A foreign resident holding company, A Co, has wholly-owned subsidiaries B Co and C Co, which are also foreign resident companies. In turn, B Co and C Co have wholly-owned subsidiaries that are Australian resident companies D Co and E Co, and F Co, respectively. E Co has an Australian resident wholly-owned subsidiary G Co.

A Co will qualify as the top company and D Co, E Co and F Co will qualify as tier-1 companies of the top company. However, only D Co

and E Co will qualify as eligible tier-1 companies of the top company. F Co will not qualify as an eligible tier-1 company of the top company as there is an entity, C Co, interposed between it and another tier-1 company, E Co, of the top company.

F Co will also not qualify as a member of the potential MEC group under the interposed foreign resident entity rules discussed in paragraphs 10.35 to 10.39 as it is not a wholly-owned subsidiary of an eligible tier-1 company of the top company. F Co would be able to choose to form a consolidated group provided it has at least one subsidiary member.

**When does a potential MEC group cease to exist?**

10.57 As outlined in paragraph 10.20, a MEC group will cease to exist at the time a potential MEC group ceases to exist. A potential MEC group must consist of at least one eligible tier-1 company for it to be in existence. Thus a potential MEC group will cease to exist when there are no eligible tier-1 companies of the top company remaining. [Schedule 1, item 1, subsections 719-30(5) and (6)]

10.58 A potential MEC group may also cease to exist as a result of a change in identity of a top company. If the eligible tier-1 companies that are members of the group immediately before the change in identity of the top company differ from the eligible tier-1 companies that are members of the group immediately after the change, the potential MEC group will cease to exist. If the eligible tier-1 companies remain the same after the change in identity of the top company, the potential MEC group will continue to exist. [Schedule 1, item 1, subsection 719-30(7)]

**Example 10.6**

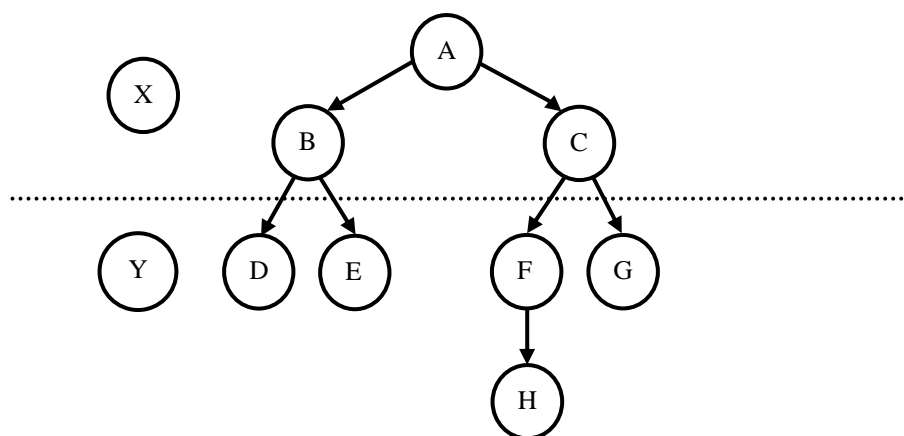

The foreign resident company A Co has 2 foreign resident wholly-owned subsidiaries B Co and C Co. B Co and C Co have Australian wholly-owned subsidiaries D Co and E Co, and F Co and G Co respectively. F Co has a resident wholly-owned subsidiary H Co.

D Co, E Co, F Co and G Co choose to form a MEC group on 1 September 2002 because they are all eligible tier-1 companies of A Co.



### **Scenario 1**

On 30 May 2003, A Co sells all of its membership interests in B Co to a foreign resident company X Co, who is not a member of the same wholly-owned group. This will cause D Co and E Co to exit the potential MEC group because the companies are no longer wholly-owned subsidiaries of the same top company as all the other eligible tier-1 companies that were members of the potential MEC group just before the change in ownership.

F Co and G Co will continue to be eligible tier-1 companies of A Co and that MEC group will continue to exist.

D Co and E Co are members of a new potential MEC group and will be able to choose to form a new MEC group. The new top company in relation to that MEC group will be X Co.

### **Scenario 2**

On 30 May 2003, X Co acquires all the membership interests in A Co. X Co becomes the top company of the potential MEC group. The eligible tier-1 companies in the potential MEC group before the change in identity of the top company are the same as the eligible tier-1 companies in the potential MEC group immediately after the change. Accordingly, the potential MEC group and the MEC group will continue to exist after the acquisition by X Co.

### **Scenario 3**

Assume X Co has an Australian resident wholly-owned subsidiary that is an eligible tier-1 company Y Co. X Co acquires all the membership interests in A Co on 1 June 2003. X Co is now the top company of a potential MEC group which does not have the same eligible tier-1 companies after the change in identity of the top company as were in the potential MEC group before the change. The MEC group D Co, E Co, F Co, G Co and H Co, will cease to exist on 31 May 2003. The potential MEC group Y Co, D Co, E Co, F Co, G Co and H Co, will be able to lodge a choice to form a MEC group and the date of effect could be no earlier than 1 June 2003.

## **Provisional head company of a MEC group**

### *Who qualifies as a provisional head company?*

10.59 A company will qualify as a provisional head company if:

- it is an eligible tier-1 company of the top company; and
- all membership interests in the eligible tier-1 company are beneficially owned by entities that are not members of the potential MEC group.

*[Schedule 1, item 1, subsection 719-94(1)]*

10.60 Membership interests in the provisional head company must be beneficially owned by entities outside the group to ensure the rules which set a cost for assets of group members, as discussed in Chapter 4, can apply as intended upon formation of the MEC group.

10.61 An additional qualifying condition applies if a company is appointed as a provisional head company because a cessation event has occurred in relation to the previous provisional head company of the group. In these circumstances, a company will only qualify as the provisional head company if it has been a member of the group since the beginning of the income year in which the cessation event happened. If the cessation event happened in the same income year in which the MEC group came into existence, the company must have been a member of the group since the time the group came into existence. [*Schedule 1, item 1, subsections 719-94(2) and (3)*]

10.62 Consideration is also being given to allowing a company, that was not in existence at the beginning of the income year in which a cessation event happened, to qualify as a provisional head company if the company has been a member of the MEC group from the time it came into existence.

10.63 The provisional head company must be a member of the MEC group from the beginning of the income year in which the cessation event happens because a provisional head company may eventually become the head company of the MEC group for the whole of the income year. Without this requirement, the head company would be assessed, in its capacity as head company of the group, on income it derived in its own capacity prior to joining the group during the income year.

#### ***Accounting period of replacement provisional head company***

10.64 A replacement provisional head company of a MEC group must take on the same accounting period as that adopted by the first provisional head company of the group. This will ensure continuity and prevent the accounting period of the head company of the group exceeding 12 months. The eligible tier-1 companies in a MEC group may have different accounting periods pre-consolidation. If the accounting period of a replacement provisional head company was not taken to be the same as that adopted by the first provisional head company, different accounting periods would apply depending on who was appointed as the replacement provisional head company of the group. [*Schedule 1, item 1, section 719-94A*]

#### ***How does a company become the provisional head company?***

10.65 How a company is appointed as a provisional head company of a MEC group differs depending on whether the company is appointed as the first provisional head company of the group or as a subsequent provisional head company.

*First provisional head company of a MEC group*

10.66 At the time a notice of choice is given to form a MEC group, all the eligible tier-1 companies in the potential MEC group must jointly appoint one of those companies which satisfy the qualifying conditions to be the *provisional head company* of the group. The appointment of a provisional head company named in the notice of choice starts to have effect at the time the MEC group comes into existence. [Schedule 1, item 1, subsections 719-93(1) and (4)]

10.67 If a MEC group is formed as a result of a special conversion event occurring in relation to a potential MEC group, the head company of the consolidated group that was an eligible tier-1 company of the top company just before the special conversion event happened will be taken to have been appointed as the *provisional head company* of the MEC group at the time the event happens. [Schedule 1, item 1, subsection 719-93(2)]

10.68 Once a company that qualifies as a provisional head company is appointed as the provisional head company, the company remains the provisional head company until a cessation event happens to the company. The appointment of the provisional head company cannot be revoked or resigned. A cessation event occurs when either:

- the company ceases to exist; or
- the company ceases to satisfy the qualifying conditions for being a provisional head company.

[Schedule 1, item 1, subsections 719-93(5) and (6)]

*Subsequent provisional head company of a MEC group*

10.69 If a cessation event happens to the provisional head company of a group, the Commissioner must be notified of another company that has been appointed as the *provisional head company* within a specified period of time of the event – the exact duration of the period of time is still being considered. However, if a cessation event happens to a provisional head company within a specified period of time before a notice of choice to form the MEC group is given to the Commissioner, notification of the appointment must instead be given to the Commissioner on the day the notice of the choice is given.

10.70 If the Commissioner is not notified of the replacement provisional head company within the specified time, the MEC group will cease to exist just after the time the cessation event happens to the last provisional head company of the group.

10.71 The appointment of a replacement provisional head company comes into effect just after the cessation event happens provided the company satisfies the qualifying conditions for being a provisional head company at that time. Notification of the appointment must be given to the Commissioner in an approved form by all eligible tier-1 companies

that were members of the group just after the cessation event. *[Schedule 1, item 1, subsections 719-93(3) and (4)]*

Eligible tier-1 company ceasing to exist before notice is given

10.72 If an eligible tier-1 company, that was in existence on the day on which the appointment of a provisional head company is to start to have effect, ceases to exist before the notice of the appointment is given to the Commissioner, the notice of appointment will still have effect. The eligible tier-1 company that ceased to exist will be taken to have authorised the first head company of the group to have made the choice on its behalf. *[Schedule 1, item 1, subsection 719-90(4)]*

***Provisional head company to be treated as head company***

10.73 If the income year of a company that is the provisional head company of a MEC group ends, the provisional head company is taken to have been the head company of the MEC group for the whole of its income year or for the period the MEC group was in existence if that is less than the income year. *[Schedule 1, item 1, subsections 719-95(1) and (2)]*

10.74 If a MEC group ceases to exist during an income year, the company that is the provisional head company immediately before the time the MEC group ceases to exist is taken to be the head company of the MEC group for that part of the income year in which the group was in existence. *[Schedule 1, item 1, subsection 719-95(3)]*

**Choosing to form a MEC group**

10.75 A MEC group can only be formed when there are at least 2 eligible tier-1 companies of the same top company in a potential MEC group. To form a MEC group, all the eligible tier-1 companies in the potential MEC group must jointly sign a notice informing the Commissioner of their choice to consolidate the group.

10.76 The notice must state the date the group is to form, which must be after 30 June 2002, and must also specify the identity of the top company in relation to the group as at that date. Once the choice to form a MEC group takes effect it cannot be revoked and the specification of the commencement day cannot be altered. *[Schedule 1, item 1, subsections 719-90(1) and (2) and subsection 719-91(1)]*

10.77 The notice informing the Commissioner of the choice to form a MEC group must be given to the Commissioner at any time during the period:

- beginning on the day the group commences; and
- ending on the day on which the first head company of the group lodges its income tax return for the income year in which the group came into existence.

10.78 However, if the head company of the group does not have to give an income tax return for that income year, the period during which the choice can be given will end at the end of the period within which the company would have been required to give an income tax return had it been required to give an income tax return for that period. [Schedule 1, item 1, subsection 719-90(3)]

10.79 All the eligible tier-1 companies in the potential MEC group that were in existence on the day that the notice to form the group takes effect must be a party to the choice. However, if an eligible tier-1 company that was in existence on that day has ceased to exist prior to the day on which the notice of the choice must be given to the Commissioner, the choice will still have effect. If these circumstances occur, the company that has ceased to exist will be assumed to have authorised the first head company of the MEC group to have made the choice on behalf of the other company. [Schedule 1, item 1, subsection 719-90(4)]

10.80 A MEC group cannot begin to exist if there is only one eligible tier-1 company. However, a single eligible tier-1 company may choose to form a consolidated group provided it has at least one subsidiary member.

10.81 If the notification of the choice to form a MEC group contains information that is materially incorrect, the choice will not take effect unless the Commissioner notifies the identified provisional head company that the choice is effective. [Schedule 1, item 1, subsections 719-91(2) and (3)]

**Example 10.7**

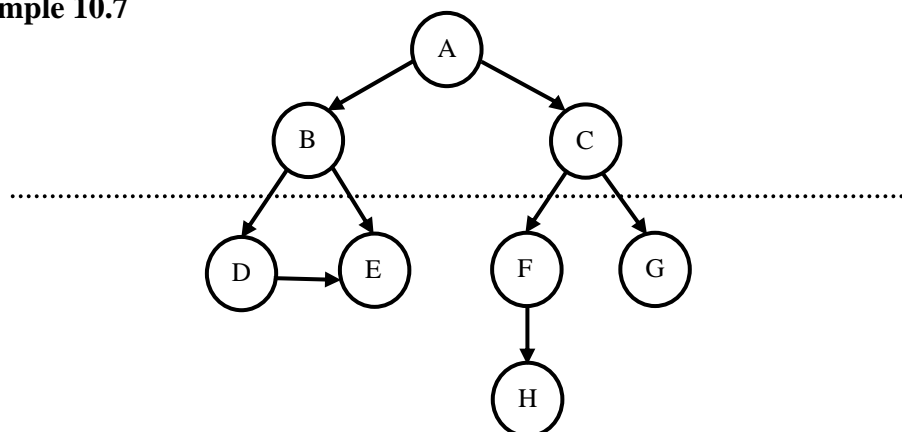

A foreign resident holding company, A Co has wholly-owned subsidiaries B Co and C Co, which are also foreign resident companies. In turn, B Co and C Co have wholly-owned subsidiaries that are Australian resident companies D Co and E Co, and F Co and G Co, respectively. F Co has an Australian resident wholly-owned subsidiary H Co.

The MEC group that could be formed would include D Co, E Co, F Co, G Co and H Co. To form a MEC group D Co, E Co, F Co and G Co would jointly have to sign a notice choosing to form a MEC group. D Co, F Co and G Co all qualify as provisional head companies but they must identify in the notice of choice the company that will be the provisional head company. E Co does not qualify as a provisional head

company as D Co holds some of the membership interests in E Co. Providing the chosen provisional head company still qualifies as a provisional head company at the end of its income year, it will be the head company of the MEC group for the whole of the income year or for the period the MEC group was in existence if that is less than a year.

## **MEC group treated as a consolidated group**

10.82 In general, a MEC group is to be treated in the same way as a consolidated group. Broadly, this means that the rules that apply to consolidated groups such as the single entity rule, the rules that set a cost for assets held by group members and the rules relating to the transfer of losses will apply equally to MEC groups. [*Schedule 1, item 1, sections 719-6 to 719-8*]

10.83 However, some modifications are required to the rules that apply to consolidated groups to ensure they apply in an appropriate manner to MEC groups and the members of a MEC group. Details on the main modifications required to those rules are discussed in the remainder of the chapter.

## **Treatment of assets on forming or joining a MEC group**

### ***What happens when an entity joins a MEC group?***

10.84 Under the operation of the single entity rule, the head company of a MEC group will be taken to have purchased each of the assets held by subsidiary members of the group at the time those entities become members of the group. The head company's cost of acquiring those assets will, in general, be worked out in the same manner as for an entity that becomes a subsidiary member of a consolidated group. However some modifications will apply when the entity that joins the MEC group is:

- an eligible tier-1 company of the top company; or
- a company that satisfies the interposed foreign resident entity tests for being a member of a potential MEC group – the interposed foreign resident entity tests are discussed in paragraphs 10.35 to 10.39.

### ***Treatment of assets held by eligible tier-1 companies***

10.85 Assets held by eligible tier-1 companies at the time they join a MEC group will be treated in a similar manner to assets held by the head company of a consolidated group. However, their treatment is akin to assets held by a head company only to the extent that the membership interests in the eligible tier-1 company, at the joining time, are beneficially owned by entities that are not members of the group.

*Eligible tier-1 company wholly-owned by non-member entities*

10.86 Where all the membership interests in an eligible tier-1 company, at the time it joins the group, are beneficially owned by entities that are not members of the group, the head company's cost of acquiring the eligible tier-1 company's assets will equal their terminating values – the terminating value of an asset is discussed in paragraph 4.41.

*Eligible tier-1 company partly owned by other MEC group members*

10.87 Where some of the membership interests in an eligible tier-1 company, at the time it joins the group, are beneficially owned by other members of the MEC group, the head company's cost of acquiring the eligible tier-1 company's assets will equal the sum of 2 components. These are:

- the *non-member component* of the purchase price; and
- the *member component* of the purchase price.

The non-member component

10.88 The non-member component will ensure that, to the extent the membership interests in the eligible tier-1 company are beneficially owned by entities that are not members of the group, the head company's cost of acquiring the assets will equal their terminating values.

**Example 10.8**

Assume an entity, A Co, joins a MEC group as an eligible tier-1 company of the top company. A Co has 60% of its membership interests beneficially owned by the top company and the other 40% of its membership interests beneficially owned by other members of the MEC group. Assume A Co has one asset with a cost base of \$100 and a market value of \$200.

Assuming there is only one class of membership interest in A Co, the non-member component of the head company's cost of acquiring the asset will equal \$60, being 60% of the terminating value (\$100) of the asset.

The member component

10.89 The member component will ensure that, to the extent the membership interests in the eligible tier-1 company are beneficially owned by other members of the MEC group, the ordinary rules which apply to set the head company's cost of acquiring the assets held by an entity that becomes a subsidiary member of a consolidated group are applied.

**Example 10.9**

Continuing on from Example 10.8, assume that the other members of the group who beneficially own the 40% of the membership interests in A Co paid \$80 to acquire the membership interests. Assuming A Co has no liabilities and that no other adjustments are required in working

out the allocable cost amount, the member component of the head company's cost of acquiring the asset will equal \$80.

The head company's total cost of acquiring the asset will equal \$140, being the sum of the non-member component and the member component.

***Treatment of assets held by certain companies who satisfy the interposed foreign resident entity tests***

10.90 Assets held by certain companies who satisfy the interposed foreign resident entity tests at the time they join a MEC group will be treated in the same manner as assets held by eligible tier-1 companies. This treatment will only apply to those companies where there is at least one membership interest in the company that does not satisfy any of the following:

- it is held by another member of the MEC group;
- it is held by an entity who holds the membership interest only as a nominee of one or more entities each of which is another member of the MEC group; and
- it is issued under an arrangement for employee shareholdings.

**Example 10.10**

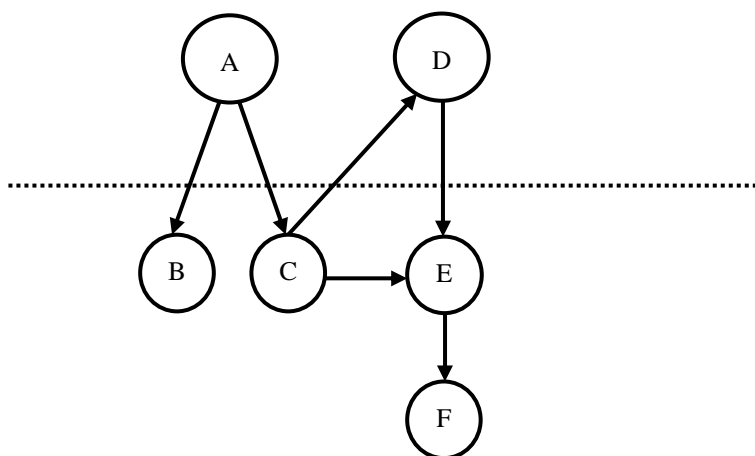

B Co and C Co, who are eligible tier-1 companies of a top company, A Co, have made a choice to form a MEC group. E Co and F Co will also qualify as members of the MEC group as a result of satisfying the interposed foreign resident entity tests for membership of the potential MEC group.

As E Co has some of its membership interests beneficially owned by an entity, D Co, who is not a member of the MEC group, the assets held by E Co will be treated in the same manner as assets held by an eligible tier-1 company. The cost to the head company of the group of each asset held by E Co will consist of 2 components – the non-member component (based on the interests beneficially owned by D Co) and the



member component (based on the interests beneficially owned by C Co).

The assets held by F Co will not be treated in the same manner as assets held by an eligible tier-1 company. This is because all the membership interests in F Co are beneficially owned by other members of the MEC group. The cost to the head company of the MEC group of each asset held by F Co will be worked out under the same rules that apply when a subsidiary member joins a consolidated group.

If, instead of E Co becoming a member of a MEC group, it became a member of a consolidated group under the equivalent tests for consolidated groups to the interposed foreign resident entity tests, the assets held by E Co would also be treated in the same manner as assets held by an eligible tier-1 company.

### ***Treatment of assets held by other members of the MEC group***

10.91 The head company's cost of acquiring the assets of other entities who join a MEC group will be worked out under the ordinary rules that apply to set a head company's cost of acquiring the assets held by an entity that becomes a subsidiary member of a consolidated group.

### ***What happens when a joining entity is the head company of another group?***

10.92 Paragraphs 4.127 to 4.131 outline special rules which apply in determining the head company's cost of acquiring assets where the joining entity is the head company of a consolidated group. The scope of those special rules will be expanded to also cover MEC groups including:

- where the top company of a MEC group acquires:
  - the top company of another MEC group; or
  - the top company of an eligible tier-1 company that is a head company of a consolidated group;
- where the top company of an eligible tier-1 company, that is the head company of a consolidated group, acquires:
  - the top company of a MEC group; or
  - the top company of an eligible tier-1 company that is the head company of a consolidated group; and
- where the members of a MEC group acquire the head company of a consolidated group.

***What happens when a joining entity is a linked entity?***

10.93 Paragraphs 4.132 to 4.138 outline special rules determining the head company's cost of acquiring assets where multiple entities, that are linked through membership interests, join a consolidated group after an event happens to one of the entities. The scope of those special rules will be expanded so that they also have application where 2 or more entities (each of which is a linked entity) become members of a MEC group as a result of an event that happens in relation to one of them.

***What happens when an entity ceases to be a subsidiary member?***

10.94 When an entity ceases to be a subsidiary member of a MEC group, the head company will be deemed to have acquired each membership interest in the entity for a cost worked out under the ordinary rules that apply when an entity ceases to be a subsidiary member of a consolidated group – Chapter 4 contains a discussion of those rules.

***Exception where an entity is an eligible tier-1 company***

10.95 An exception will apply when the entity that ceases to be a subsidiary member is an eligible tier-1 company of the top company. In those circumstances, the ordinary rules that apply when an entity ceases to be a subsidiary member of a consolidated group will only be applied to the extent that the membership interests in the eligible tier-1 company are beneficially owned by other members of the MEC group. Paragraphs 10.100 to 10.111 discuss the treatment of those membership interests that are not beneficially owned by entities who are members of the MEC group.

***Exception where a company satisfies the interposed foreign resident entity tests***

10.96 An exception will also apply when certain companies that satisfy the interposed foreign resident entity tests exit a MEC group. For the exception to apply to the company, at least one membership interest in the company must not satisfy any of the following:

- it is held by another member of the potential MEC group;
- it is held by an entity who holds the membership interest only as a nominee of one or more entities each of which is another member of the potential MEC group; or
- it is issued under an arrangement for employee shareholdings.

10.97 Where an entity holds membership interests that do not satisfy any of the tests in paragraph 10.96, the rules that apply when an entity ceases to be a subsidiary member of a consolidated group will be modified so that they also apply to those membership interests.

### **Example 10.11**

Assuming the same facts as in Example 10.10, assume E Co subsequently exits the MEC group. The ordinary rules that apply when an entity ceases to be a subsidiary member of a consolidated group will apply to the extent that the membership interests in E Co are beneficially owned by C Co.

To the extent that the membership interests in E Co are beneficially owned by D Co, the ordinary rules that apply when an entity ceases to be a subsidiary member of a consolidated group will be modified to ensure that they can also apply in relation to the membership interests owned by D Co.

### ***Transferring membership interests to a non-member entity***

10.98 In a MEC group, it is possible for a membership interest in a subsidiary member to be transferred to an entity that is not a member of the group without causing the subsidiary member to exit the group. This could occur when a membership interest in a subsidiary member is transferred to the top company. Where this occurs, the head company will be taken to have acquired each transferred membership interest in the subsidiary member for a cost worked out under the rules that apply when an entity ceases to be a subsidiary member of a consolidated group.

### ***Transferring membership interests in an eligible tier-1 company to a member of the MEC group***

10.99 Consideration is being given to whether modifications are required to the rules which ascertain the head company's cost of acquiring assets where membership interests in an eligible tier-1 company, beneficially owned by an entity that is not a member of the MEC group, are transferred to another entity that is a group member.

## **Treatment of membership interests in eligible tier-1 companies held by entities that are not group members**

10.100 Generally, under consolidation, assets can be freely transferred between group members without triggering income tax consequences. To facilitate the free transfer of assets between group members, the membership interests in eligible tier-1 companies of a MEC group, that are held by entities that are not members of the group, are to be pooled just before the time certain trigger events occur. Pooling facilitates the free transfer of assets within a MEC group by removing the need to make value shifting adjustments to the membership interests each time there is a transfer of value between MEC group members. Membership interests in eligible tier-1 companies of a MEC group that are held by entities that are not members of the group are referred to in paragraphs 10.101 to 10.111 as *external membership interests*.

10.101 If an eligible tier-1 company exits a MEC group, the original cost base of the external membership interests in the eligible tier-1 company may no longer be appropriate. This is because assets held at the time the eligible tier-1 company was acquired may now be held by other members of the group. Alternatively, assets held by other members of the group may now be held by the exiting eligible tier-1 company.

10.102 To address this, the cost base of all external membership interests in eligible tier-1 companies will be pooled just before the time certain events occur and a cost re-allocated to each external membership interest based on an allocation from the pool. The percentage allocation from the pool will equal the market value of the external membership interest as a proportion of the total market value of all external membership interests in all eligible tier-1 companies.

10.103 The cost of the external membership interest will be used for the purpose of determining:

- the cost base of the membership interest for CGT purposes; and
- the cost price of the membership interest if the interest is held on revenue account including as trading stock.

*Events which will trigger pooling*

10.104 The cost base of all external membership interests in all the eligible tier-1 companies of a top company will be pooled just before the time each one of the following events, which are called *trigger events*, occurs:

- an eligible tier-1 company of a top company ceases to be a member of the MEC group; or
- a CGT event happens to an external membership interest in an eligible tier-1 company but the eligible tier-1 company continues to be a member of the MEC group.

10.105 The first trigger event ensures the external membership interests in the exiting eligible tier-1 company will have an appropriate cost if they are disposed of, either at the time the eligible tier-1 company exits the group or at a later time. The second trigger event ensures the external membership interests have an appropriate cost just before the time a CGT event happens in relation to the interest. An example of the second trigger event is if an external membership interest in an eligible tier-1 company is transferred to a MEC group member.

**Example 10.12**

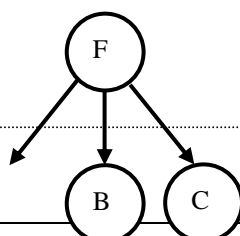

A

F Co has 3 wholly-owned Australian subsidiaries, A Co, B Co and C Co. A Co, B Co and C Co each choose to form a MEC group on 1 July 2002. At that time, the cost base of the membership interests in each subsidiary is \$100.

On 1 July 2003, F Co disposes of its membership interests in C Co to a company that is not a member of the same wholly-owned group. This causes C Co to cease to be a member of the MEC group. As a trigger event has occurred, it is necessary to determine a cost for each external membership interest in each of the eligible tier-1 companies just before the time of the trigger event. At that time, the market values of the external membership interests in each eligible tier-1 company were as follows.

A Co – \$280

B Co – \$20

C Co – \$300

By re-allocating from the cost base pool of \$300 (i.e. \$100 + \$100 + \$100), F Co will be taken to have a new cost for each of the external membership interests in each eligible tier-1 company equal to the following amounts.

A Co – \$140 [ $(\$280 / \$600) \times \$300$ ]

B Co – \$10 [ $(\$20 / \$600) \times \$300$ ]

C Co – \$150 [ $(\$300 / \$600) \times \$300$ ]

Assuming the membership interests in C Co were disposed of for their market value, F Co will therefore make a \$150 gain on the disposal of the membership interests in C Co. If a subsequent trigger event occurs in relation to the MEC group, the balance of the cost base pool to be re-allocated will equal \$150 (i.e. \$300 – \$150).

#### *Different cost for reduced cost base purposes*

10.106 A different cost will apply solely for the purpose of working out what is the reduced cost base of an external membership interest in an eligible tier-1 company. The different cost will be worked out by pooling the reduced cost base, instead of the cost base, of each external membership interest in each eligible tier-1 company just before a trigger event. The percentage allocation from the reduced cost base pool will be made in the same manner as an allocation from the cost base pool.

*Pre-CGT status*

10.107 The allocation of a new cost to the external membership interests in eligible tier-1 companies will not affect the number of those interests that are taken to be pre-CGT assets.

*Employee shares*

10.108 The treatment outlined for external membership interests in eligible tier-1 companies will not apply in relation to those external membership interests in companies that are issued under arrangements for employee shareholdings.

*Membership interests held as nominees*

10.109 The treatment outlined for external membership interests in eligible tier-1 companies will also not apply to those interests held by an entity as a nominee of one or more entities each of which is a member of the MEC group.

*Provisions which adjust the cost base of membership interests*

10.110 Under the ITAA 1936 and the ITAA 1997, various provisions apply to adjust the cost base or reduced cost base of membership interests in an entity – for example, Division 138 and Subdivision 165-CD of the ITAA 1997.

10.111 Because assets may be freely transferred between members of a MEC group without income tax consequences being triggered, it is possible for these cost base adjustment provisions not to apply to external membership interests in eligible tier-1 companies in a manner which is consistent with their operation under the current law. As a result, consideration is being given to whether modifications are required to ensure provisions which adjust cost bases apply as intended to external membership interests in eligible tier-1 companies.

## **Distributions made to entities who are not group members**

10.112 The company that is the head company of a MEC group at a particular time maintains the franking account on behalf of the group. Accordingly, distributions made by eligible tier-1 companies of a MEC group, other than by the company that is the head company, would not be able to be franked. This would result in a foreign resident recipient of the distribution having a liability to pay withholding tax.

10.113 To overcome this, any frankable distribution that is made by an eligible tier-1 company who is a member of a MEC group (other than the head company) to an entity who is not a member of the group will be taken to be made by the head company. Treating the head company as having made the distribution will also ensure that the same benchmark

franking percentage will apply to all distributions made by eligible tier-1 companies to entities who are not members of the group.

10.114 A company that becomes a member of a MEC group as a result of satisfying the interposed foreign resident entity tests may also have some of its membership interests held by entities who are not members of the group. To allow distributions made to those entities who are not members of the group to be franked, any frankable distribution that is made by a company that satisfies the interposed foreign resident entity tests will also be taken to be made by the head company of the group.

10.115 Where a company that becomes a member of a MEC group is an exempting company or a former exempting company, the franking credits transferred to the head company will continue to be subject to the franking credit trading rules applicable to exempting companies.

10.116 The rules discussed in paragraphs 10.114 and 10.115 will also apply equally to a company that becomes a subsidiary member of a consolidated group.

### **Transfer of tax attributes to a new provisional head company**

10.117 If all the eligible tier-1 companies of a MEC group jointly appoint a new provisional head company, all of the tax attributes (e.g. losses and franking credits) of the group will be transferred from the old provisional head company to the new provisional head company. The transfer of tax attributes is intended to produce a tax-neutral outcome irrespective of which eligible tier-1 company is appointed as the new provisional head company.

#### ***Transfer of losses***

10.118 Any losses transferred to the new provisional head company will be taken to have been incurred in the same income year in which they were incurred by the old head company. This may result in the continuity of ownership test for losses being failed if an eligible tier-1 company has been acquired by the top company subsequent to a loss being made by a previous head company of the group. This could produce inappropriate results as a choice of one eligible tier-1 company as provisional head company may result in the continuity of ownership test for losses being satisfied, whereas a choice of another eligible tier-1 company as provisional head company may result in the continuity of ownership test not being satisfied.

10.119 Rules are being developed to ensure that the continuity of ownership test for losses applies in a consistent manner irrespective of which eligible tier-1 company is appointed as the provisional head company.

### **Change of ownership or control of an eligible tier-1 company**

10.120 Under Subdivision 165-CD of the ITAA 1997, adjustments are made to the tax values of certain membership and debt interests in entities to prevent multiple recognition of a company's losses. The adjustments to the interests are triggered when:

- a change occurs in the ownership or control of a company; and
- the company has losses at the time of that change.

10.121 Where a MEC group consists of more than one eligible tier-1 company, Subdivision 165-CD may apply inappropriately because all realised losses will be held by the eligible tier-1 company that is the head company of the MEC group, and not by the company that actually made the loss. Differing tax outcomes may therefore arise depending on whether or not the eligible tier-1 company in which the change in ownership or control occurs is the head company of the MEC group.

10.122 Rules are being developed to ensure Subdivision 165-CD applies to eligible tier-1 companies who are members of a MEC group in a manner which is consistent with the current operation of the law.

### **Imposing an income tax liability on the head company of a MEC group**

10.123 Separate Imposition Acts will be introduced for the purpose of imposing, on the head company of a MEC group, any liability arising as a result of the operation of the single entity rule.

### **Application and transitional provisions**

10.124 The rules dealing with MEC groups are part of the consolidation regime which commences from 1 July 2002.

10.125 Paragraphs 4.198 to 4.219 discuss transitional rules for consolidated groups that modify:

- what is the head company's cost of acquiring the assets of an entity that becomes a subsidiary member of a consolidated group; and
- what is the head company's cost for the membership interests in an entity that leaves a consolidated group.

10.126 Those transitional rules will also apply to MEC groups but with some modifications to accommodate the fact that a MEC group does not have a single resident head company.



10.127 The transitional rules will apply to the head company of a MEC group if the MEC group is formed during the financial year commencing on 1 July 2002 and one of the 2 conditions listed in paragraphs 10.129 and 10.130 exists for the period:

- starting at the end of 30 June 2002; and
- ending at the time the MEC group comes into existence.

10.128 The time the MEC group comes into existence is referred to in paragraphs 10.129 and 10.130 as the *formation time*.

10.129 The first condition is that an entity that became a member of the MEC group at the formation time would have been, throughout the period, a wholly-owned subsidiary of an eligible tier-1 company of the MEC group if that company had held, throughout the period, all the membership interests that were held by eligible tier-1 companies who became members of the MEC group at that time.

10.130 The second condition is that, throughout the period, one or more membership interests in an eligible tier-1 company that became a member of the MEC group at the formation time were held by an entity that became a member of the group at that time.

## **Consequential amendments**

10.131 Amendments consequential to the measures discussed in this chapter will be included in subsequent legislation.



---

## **Chapter 11**

# ***Interaction with international provisions***

---

### **Outline of chapter**

11.1 This chapter explains the proposals for dealing with the transfer of excess foreign tax credits to the head company of a consolidated group at the time the group is formed and at the time an entity joins a consolidated group.

11.2 This chapter also explains the proposals for dealing with attribution accounts and attributed tax accounts maintained for the purposes of the CFC and FIF measures, for entities that join or form a consolidated group, or that leave a consolidated group.

### **Context of reform**

11.3 The proposal to deal with the transfer and pooling of excess foreign tax credits by the head company was outlined in *A Platform for Consultation*. The foreign tax credit provisions mirror current law on intra-group transfers of excess foreign tax credits.

11.4 Excess foreign tax credits held by a member of a group can be transferred to another member of the same wholly-owned group under the current law, providing both companies have been members of the same group for the whole of the income year in which the credits are transferred.

11.5 The proposal to deal with the transfer of attribution and attributed tax account surpluses in relation to the CFC and FIF regimes was outlined in *A Platform for Consultation*. The ability to transfer attribution and attributed tax account surpluses will ensure the policy behind the requirement for those accounts is maintained.

11.6 There is little need for the ability to transfer these surpluses under the existing law. However, under consolidation the taxpayer that receives a distribution of profits that have been subject to accruals taxation may well be different from the taxpayer that was subject to accruals taxation pre-consolidation.

## **Summary of new law**

### **Transferring excess foreign tax credits**

11.7 The consolidation regime will operate to ensure a consolidated group is treated as a single entity. Under the single entity principle, only the head company will include foreign income in its assessable income, therefore, only the head company will be able to use foreign tax credits to reduce its Australian tax liabilities.

11.8 The subsidiary members will transfer their excess credits to the head company at the formation or joining time to ensure the head company can use the excess credits.

11.9 During the period that an entity is a member of the consolidated group, where it pays foreign tax on foreign income, the head company will be assessed on the foreign income and will be deemed to have paid the foreign tax.

11.10 When an entity leaves a consolidated group it will not take with it any excess foreign tax credits.

### **Transferring attribution and attributed tax account surpluses**

11.11 Under the single entity principle, only the head company will be able to operate attribution accounts and attributed tax accounts for the purposes of the CFC and FIF measures during the period of consolidation. The pre-consolidation balances of these accounts will be transferred to the head company to facilitate the use of the surpluses during consolidation.

11.12 Subsidiary members of a consolidated group will have dormant attribution and attributed tax accounts.

11.13 When an entity with an interest in a CFC or FIF leaves a group, it will need to maintain attribution accounts and attributed tax accounts for each attribution account entity in which it has an interest. A proportion of the attribution account surpluses and attributed tax account surpluses the head company has in relation to the interests in the CFC or FIF that leaves with the entity will be transferred to the leaving entity.

## Comparison of key features of new law and current law

<i>New law</i>	<i>Current law</i>
Excess foreign tax credits will be transferred to the head company of a consolidated group from the subsidiary members of the group. There will be a restriction on utilising the excess credits until the head company has held the transferred-in credits for 12 months. However, there is a conditional exception for pre-existing wholly-owned groups that choose to consolidate.	A credit company can transfer excess foreign tax credits to an income company if they have been members of the same group for the whole of the income year in which the transfer is made.
There will be no requirement for agreements between subsidiary members and the head company of a consolidated group.	There must be a signed agreement between the credit company and the income company.
Attribution and attributed tax account surpluses of a joining entity are transferred to the head company.	The taxpayer which has the CFC or FIF interest is entitled to the benefit of the attribution or attributed tax account. There is no transfer of benefits within a group.
The head company is to maintain the attribution accounts for each attribution account entity in which it has an interest as the head company (despite legal ownership being held by a subsidiary member of the group).	Attribution and attributed tax accounts are kept by a taxpayer for each attribution account entity in which the taxpayer has an interest.
An entity that leaves a consolidated group taking with it an interest in a CFC or FIF will be able to take a proportion of any attribution or attributed tax account surpluses the head company has in relation to those interests.	There is no parallel.

## Detailed explanation of new law

### Transfer of foreign tax credits

#### *On formation and joining a consolidated group*

11.14 The proposed measure will provide for the excess foreign tax credit balances, held by each of the members of a wholly-owned group that chooses to consolidate, to be transferred to the head company. The excess credits will be transferred at the time the choice to consolidate takes effect. Where an entity joins a consolidated group its excess credits will be transferred to the head company at the joining time. The head

company can pool all the transferred-in excess credits with its own excess credits according to the class of income and the income year in which the credits arose.

11.15 The amount of the excess credit balances to be transferred to the head company will be calculated at the time of formation or joining the group and may include current year excess credit amounts. Current year excess credit amounts may arise where an entity joins a consolidated group during its income year and the foreign tax paid, from the beginning of the entity's income year until the time it joins the group, is greater than the Australian tax payable on the class of foreign income for the same period.

11.16 To remain consistent with the current foreign tax credit transfer provisions, the following conditions will apply regarding the utilisation of the excess credits transferred to the head company in the consolidated group:

- The head company can use, at the end of its first income year, the transferred-in excess credits obtained from those entities that had been members of the same wholly-owned group for 12 months at that time based on the assumption that those entities are still members of the consolidated group at the end of the income year even if they have in fact left the group by that time.
- If an entity has not been a member of the wholly-owned group for the 12 months as at the end of the head company's first income year based on the above assumption, (or has joined the consolidated group during the income year), the head company must wait until the following income year before it can use the transferred-in excess credits from that member. The entity does not have to remain a member of the consolidated group once the excess credits are transferred to the head company.

11.17 The excess credit balances the head company may have held in its own right can be used to offset the Australian tax liability on any foreign income of the group in the relevant class.

11.18 During the period that an entity is a member of the consolidated group, where it pays foreign tax on foreign income, the head company will be assessed on the foreign income and will be deemed to have paid and been personally liable for the foreign tax.

***No transfers to an entity leaving a group***

11.19 Where an entity leaves a consolidated group it will not have any excess credit balance at the time of leaving. Any foreign tax paid while it was a member of the group in the year the entity left the group will not give rise to a foreign tax credit for that entity but may give rise to a credit for the head company.

## **Transfer of attribution account and attributed tax account surpluses**

### ***On formation or joining a consolidated group***

11.20 The proposed measure will provide that an entity that becomes a subsidiary member of a consolidated group will transfer to the head company the attribution surpluses (CFC), FIF attribution surpluses, attributed tax account surpluses (CFC) and FIF attributed tax account surpluses at the time it joins a consolidated group. The measure will apply at the time a consolidated group comes into existence as well as for entities joining an existing consolidated group.

11.21 The transfer of attribution and attributed tax account surpluses of a joining entity is effected by an attribution or attributed tax account credit arising in the accounts of the head company. The credit arises at the joining time (or formation time) and is equal to the attribution or attributed tax account surplus calculated at that time for each attribution account entity of the joining entity.

11.22 A corresponding and equal attribution or attributed tax account debit will arise in the relevant accounts of the joining entity at the joining or formation time. The attribution and attributed tax accounts of the joining entity will have a nil balance after joining a consolidated group.

11.23 The attribution and attributed tax accounts of the subsidiary members will be dormant during the time entities are subsidiary members of a consolidated group. That is, no credits or debits will be made to those accounts.

11.24 Any attribution account debits or credits that would otherwise arise in a subsidiary member's attribution or attributed tax accounts arise instead in the head company's accounts as the head company will be the only entity that can operate the relevant accounts.

### ***For an entity that leaves a consolidated group***

11.25 Where an entity leaves a consolidated group taking with it an interest in a CFC or FIF, the leaving entity will be able to take a proportion of the head company's attribution surplus and/or attributed tax account surplus at the time it leaves the consolidated group.

11.26 The proportion of the attribution or attributed tax account surpluses transferred to the leaving entity is calculated, at the leaving time, based on the percentage of the group's interest in the CFC or FIF held by the leaving entity.

## **Application and transitional provisions**

11.27 In general these amendments will apply to groups that consolidate on or after 1 July 2002.

## **Consequential amendments**

11.28 As a general rule, from 1 July 2002, the transfer of excess foreign tax credits between members of a wholly-owned group will no longer be available. However, if a head company with a SAP makes an election to consolidate on the first day of the next SAP income year commencing after 1 July 2002, the provisions for transferring excess foreign tax credits will continue to operate until that date.

## **Other international provisions impacted by consolidation**

11.29 The impacts on the following provisions (ITAA 1936 unless otherwise noted) of the new consolidation regime are being considered:

- Division 6AAA (transferor trust measures), sections 96B and 96C;
- section 99B;
- sections 23AH and 23AJ;
- the calculation of attributable income under Part X, Part XI, and Division 6AAA;
- Division 9A (offshore banking units);
- Division 13 (transfer pricing);
- Division 820 of the ITAA 1997 (thin capitalisation measures); and
- foreign income accounts (yet to be legislated).



---

# **Chapter 12**

## ***Consolidated groups with life insurance companies***

---

### **Outline of chapter**

12.1 This chapter explains the special rules for consolidated groups that have life insurance company members.

### **Context of reform**

12.2 The income tax law applies special rules for taxing life insurance companies. In particular, Division 320 of the ITAA 1997 divides the taxable income of a life insurance company into 2 classes:

- the ordinary class of taxable income which is taxed at the company tax rate; and
- the complying superannuation class of taxable income which is taxed at the 15% complying superannuation rate.

12.3 The ordinary class of taxable income is the total taxable income less the complying superannuation class of taxable income.

12.4 The complying superannuation class of taxable income consists of 3 components:

- the RSA component;
- the virtual PST component; and
- the specified rollover component.

12.5 In addition, under Division 320 a life insurance company can segregate assets into:

- virtual PST assets which are used for the sole purpose of discharging virtual PST liabilities, appropriate provisions for tax on unrealised gains and relevant PAYG instalments; and
- segregated exempt assets which are used for the sole purpose of discharging exempt life insurance policy liabilities and appropriate provisions for tax on unrealised gains.

12.6 The rules in Division 320, together with other provisions that apply specifically to life insurance companies, need to apply appropriately to the head companies of consolidated groups that have life insurance company members. This gives effect to the single entity principle in a way that preserves the recommendations relating to life insurance companies in *A Tax System Redesigned*. Under those recommendations, life insurance companies segregate assets relating to certain types of business. In addition, to ensure amounts are taxed at the correct rate, certain transactions between the segregated assets of life insurance companies and the ordinary part of their business are taxable events.

## **Summary of new law**

12.7 The provisions that apply specifically to life insurance companies will ensure that the head company of a consolidated group that has one or more life insurance company members will be treated as a life insurance company for taxation purposes.

12.8 In addition:

- the rules relating to the segregated assets of life insurance companies will apply jointly to all members of the consolidated group that are life insurance companies;
- the virtual PST component of the complying superannuation class of taxable income will be worked out as if the life insurance company was not a member of the consolidated group;
- as a consequence of the special rules for taxing life insurance companies, the rules that apply to the treatment of the assets of an entity that joins or leaves a consolidated group will be modified where that joining or leaving entity is a life insurance company; and
- for a joining or leaving entity that is a life insurance company, the value of liabilities relating to the net risk components of life insurance policies and the net investment component of ordinary life insurance policies will be prescribed.

## Comparison of key features of new law and current law

<i>New law</i>	<i>Current law</i>
<p>The special rules that apply to tax life insurance companies will apply to the head company of a consolidated group if that consolidated group has one or more members that are life insurance companies.</p> <p>These special rules will ensure that the life insurance companies that become subsidiary members of a consolidated group are treated in a manner that is similar to the treatment they are afforded under the existing tax law.</p> <p>The special rules will ensure that:</p> <ul style="list-style-type: none"> <li>• the virtual PST component of the complying superannuation class of taxable income and income from segregated exempt assets will be worked out jointly for all life insurance companies that are members of the consolidated group;</li> <li>• the rules that apply to the treatment of the assets of an entity that joins or leaves a consolidated group will not apply to the virtual PST assets or the segregated exempt assets of a life insurance company that is a joining or leaving entity; and</li> <li>• for the purpose of working out the allocable cost amount of a joining entity that is a life insurance company: <ul style="list-style-type: none"> <li>– the value of liabilities relating to the net risk components of life insurance policies will be consistent with the value of those liabilities worked out under Division 320; and</li> <li>– the value of liabilities relating to the net investment component of ordinary life insurance policies will be worked out consistently with the value of virtual PST liabilities.</li> </ul> </li> </ul> <p>These valuation rules will also apply</p>	<p>The special rules that apply to tax life insurance companies will not apply to the head company of a consolidated group that has one or more members that are life insurance companies unless that head company is a life insurance company.</p>

<i>New law</i>	<i>Current law</i>
when a life insurance company leaves a consolidated group.	

## Detailed explanation of new law

### What is the object of the provisions that will apply to consolidated groups with life insurance companies?

12.9 The object of the provisions that will apply to consolidated groups with life insurance companies is to ensure that appropriate tax treatment is applied to life insurance companies which become members of a consolidated group by:

- treating the head company of the group as a life insurance company for certain purposes;
- treating matters related to the virtual PST assets and segregated exempt assets of all life insurance companies within the group jointly;
- excluding the virtual PST assets and segregated exempt assets and related liabilities from the operation of certain provisions relating to the payment for assets and liabilities where entities become subsidiary members; and
- modifying the operation of certain provisions relating to the payment for assets and liabilities for life insurance companies that join or leave a consolidated group.

### How will the head company of a consolidated group that has life insurance company members be treated?

#### *The head company will be taken to be a life insurance company*

12.10 Special taxation rules apply to life insurance companies. Those rules need to apply to the head company of a consolidated group that has members that are life insurance companies.

12.11 A life insurance company is defined under subsection 995-1 of the ITAA 1997 to mean a company registered under the *Life Insurance Act 1995*. Therefore, if the head company is a life insurance company, the special taxation rules in the existing law that apply to life insurance companies will continue to apply to the head company.

12.12 The amendments will ensure that the head company of a consolidated group that has subsidiary members that are life insurance companies, is taken to be a life insurance company for the purposes of an assessment of income tax during the period when any subsidiary members of the group are life insurance companies.

12.13 This will ensure, broadly, that:

- certain statutory income of life insurance companies is included in the assessable income of the head company;
- certain exempt income of life insurance companies is exempt income of the head company;
- certain specific deductions of life insurance companies are allowable deductions of the head company;
- the rules that apply to the segregated virtual PST assets and segregated exempt assets of life insurance companies apply to the head company;
- the dividend imputation rules that apply to life insurance companies apply appropriately to the head company; and
- the provisions of the *Income Tax Rates Act 1986* that apply to life insurance companies apply to the head company so that the head company will be taxed at a rate of 15% on the complying superannuation class of its taxable income.

***The segregated assets of life insurance companies within the group will be taken to be joined***

12.14 Division 320 contains, among other things, special rules for:

- establishing and maintaining the virtual PST assets of a life insurance company;
- working out the virtual PST component of the complying superannuation class of taxable income of a life insurance company; and
- establishing and maintaining the segregated exempt assets of a life insurance company.

12.15 A consolidated group may have 2 or more members that are life insurance companies – each of which has their own virtual PST and segregated exempt assets. The amendments will ensure that, following consolidation, the rules in Division 320 are applied jointly to the virtual PST and segregated exempt assets of all members of the group that are life insurance companies. That is the consolidated group will be taken to have a single virtual PST and a single pool of segregated exempt assets.

Consequently, the valuations required in relation to virtual PST assets under Subdivision 320-F and segregated exempt assets under Subdivision 320-H will be done jointly.

12.16 However, rules will need to be developed to ensure that any virtual PST losses of life insurance companies that are members of a consolidated group are treated neutrally.

***The life insurance company will be taken not to be a member of the group for the purpose of working out the head company's virtual PST component***

12.17 The virtual PST component of the complying superannuation class of taxable income is worked out under section 320-205 and includes, among other things, income derived from the investment of virtual PST assets. Virtual PST assets can include, for example, units in wholly-owned unit trusts that are members of the consolidated group and shares in companies that are members of the consolidated group.

12.18 Therefore, to ensure that the virtual PST component of the complying superannuation class of taxable income of a consolidated group that has a life insurance company member is properly determined, that component of taxable income will be worked out as though the life insurance company was not a member of the group during the period.

12.19 In addition, if the virtual PST component worked out for a particular life insurance company in an income year is negative, that amount will be taken to be nil for the purpose of working out the head company's virtual PST component for that income year. The amount will still be taken into account in working out the head company's virtual PST component in subsequent income years.

12.20 The amendments will ensure that units in wholly-owned unit trusts that are members of the consolidated group and shares in companies that are members of the consolidated group continue to be recognised as virtual PST assets. The assessable income generated on those assets will continue to be included in the virtual PST component of the complying superannuation class of taxable income.

***The life insurance company will be taken not to be a member of the group for the purpose of working out the head company's income derived from segregated exempt assets***

12.21 A life insurance company is exempt from tax on ordinary income and statutory income derived from segregated exempt assets (paragraph 320-35(1)(b)). Similar to virtual PST assets, segregated exempt assets can include, for example, units in wholly-owned unit trusts that are members of the consolidated group and shares in companies that are members of the consolidated group.

12.22 Therefore, to ensure that the income derived from segregated exempt assets of a consolidated group that has a life insurance company member is properly determined, that income will be worked out as though the life insurance company was not a member of the group during the period.

12.23 The amendments will ensure that units in wholly-owned unit trusts that are members of the consolidated group and shares in companies that are members of the consolidated group continue to be recognised as segregated exempt assets. The income generated on those assets will continue to be exempt from tax.

### **How will the rules about joining a consolidated group be modified if the joining entity is a life insurance company?**

#### ***Segregated assets and associated liabilities will be ignored***

12.24 If an entity joins a consolidated group, the cost of the assets to the group is aligned with the group's cost of acquiring the membership interests in the entity and the liabilities of the entity at the joining time. Similar rules apply in the group formation case.

12.25 Under Division 320 a life insurance company can segregate virtual PST assets and segregated exempt assets. The transfer value (broadly the market value) of assets segregated must not exceed the value of relevant liabilities. An annual valuation of assets is required at the end of each income year.

12.26 If the value of the assets segregated exceeds the value of relevant liabilities, the excess assets must be transferred out of the segregated pool within specified time frames. The transfer is taken to be made in the income year to which the annual valuation relates. If the value of the assets is less than the value of relevant liabilities, additional assets can be transferred to the segregated pool. If those additional assets are transferred to the segregated pool within 30 days of the annual valuation, the transfer is taken to be made in the income year to which the annual valuation relates.

12.27 If a life insurance company becomes a subsidiary member of a consolidated group, the company's income year ends at that time. Therefore, under Division 320, the company will be required to value its virtual PST assets and segregated exempt assets and transfer assets out of or into the segregated pools, as appropriate, at that time.

12.28 A life insurance company that joins a consolidated group is likely to hold a significant amount of assets in its virtual PST and segregated exempt assets. As the virtual PST assets and segregated exempt assets essentially relate to policyholders and the value of those assets is aligned with the value of virtual PST liabilities (and appropriate provisions for tax on unrealised gains and relevant PAYG instalments) and exempt life

insurance policy liabilities (and appropriate provisions for tax on unrealised gains), there is no need to apply the provisions relating to the payment for assets and liabilities for companies that join a consolidated group to the segregated assets and liabilities of a joining entity that is a life insurance company.

12.29 Therefore, if a life insurance company joins a consolidated group as a subsidiary member, the head company will be taken not to purchase the virtual PST assets and segregated exempt assets of the life insurance company.

12.30 Even though the head company is taken not to purchase the virtual PST assets and segregated exempt assets of the joining life insurance company, the head company does hold those assets for taxation purposes. The cost base of the virtual PST assets and segregated exempt assets will be the joining life insurance company's cost base for those assets at the joining time – that is, the cost base will not be reset.

12.31 In addition, as the head company is taken not to purchase the virtual PST assets and segregated exempt assets of the joining life insurance company, the value of virtual PST liabilities (and appropriate provisions for tax on unrealised gains and relevant PAYG instalments) and exempt life insurance policy liabilities (and appropriate provisions for tax on unrealised gains), will be ignored for the purposes of working out the sum of the liabilities of the joining life insurance company.

12.32 The modifications that apply when a life insurance company joins a consolidated group will also apply on the formation of a consolidated group when a subsidiary member of that group is a life insurance company.

***Special valuation rules will apply to risk policy liabilities and ordinary investment policy liabilities***

12.33 When an entity joins a consolidated group, the entity's allocable cost amount must be worked out. A component of the allocable cost amount for a joining entity is the value of the joining entity's liabilities. The value of the joining entity's liabilities is based on the value of those liabilities used for accounting purposes.

12.34 However, Division 320 prescribes a basis that must be used by life insurance companies for valuing the liabilities under the net risk components of life insurance policies. Division 320 also prescribes a basis for valuing policyholder liabilities relating to virtual PST policies and exempt life insurance policies.

12.35 The amendments will ensure that the basis for valuing liabilities under the net risk components of life insurance policies for consolidation purposes is consistent with the basis of valuing those liabilities under section 320-85.



12.36 In addition, the basis of valuing liabilities under the net investment component of ordinary life insurance policies will be prescribed for consolidation purposes so that it is consistent with the basis of valuing virtual PST liabilities under section 320-190.

12.37 That is, the value of liabilities under the net investment component of ordinary life insurance policies for the purposes of working out the sum of the joining life insurance company's liabilities will be:

- for ordinary participating and discretionary policies – the value of supporting assets (as defined in the Valuation Standard – i.e. Actuarial Standard 1.02) and the policy owners' retained profits in respect of the net investment component of those policies; and
- for other ordinary life insurance policies – the current termination value (as defined in the Solvency Standard – i.e. Actuarial Standard 2.02) of the net investment component of those policies.

12.38 These special valuation rules will also apply on the formation of a consolidated group when a subsidiary member of that group is a life insurance company.

### **How will the rules about leaving a consolidated group be modified if the leaving entity is a life insurance company?**

#### *Segregated assets and associated liabilities will be ignored*

12.39 The rules that apply to an entity that leaves a consolidated group are similar to those that apply when an entity joins a consolidated group.

12.40 The amendments will ensure that the head company of a consolidated group will be required to value the virtual PST assets and segregated exempt assets under Division 320 and transfer assets out of or into the segregated pools, as appropriate, of a leaving life insurance company at the time that the company leaves the consolidated group.

12.41 As the virtual PST assets and segregated exempt assets essentially relate to policyholders and the value of those assets are aligned with the value of virtual PST liabilities (and appropriate provisions for tax on unrealised gains and relevant PAYG instalments) and exempt life insurance policy liabilities (and appropriate provisions for tax on unrealised gains), there is no need to apply the provisions relating to the payment for membership interests and assets for companies that leave a consolidated group to the segregated assets and liabilities of a leaving entity that is a life insurance company.

12.42 Therefore, if a life insurance company leaves a consolidated group, the virtual PST assets and segregated exempt assets of the life insurance company will not be taken into account in determining the terminating value of relevant assets held by the head company.

12.43 In addition, the value of virtual PST liabilities (and appropriate provisions for tax on unrealised gains and relevant PAYG instalments) and exempt life insurance policy liabilities (and appropriate provisions for tax on unrealised gains) of the leaving life insurance company will be ignored.

***Special valuation rules will apply to risk policy liabilities and ordinary investment policy liabilities***

12.44 The special valuation rules that apply to determine the value of liabilities under the net risk components of life insurance policies and under the net investment component of ordinary life insurance policies when a life insurance company joins a consolidated group, will also apply when a life insurance company leaves a consolidated group.

## **Application and transitional provisions**

12.45 In general, these amendments will apply to groups that consolidate on or after 1 July 2002. Transitional provisions that give effect to the measures discussed in this chapter will be contained in subsequent legislation.

## **Consequential amendments**

12.46 Amendments consequential to the measures discussed in this chapter will be included in subsequent legislation.

---

# Chapter 13

## ***Removal of grouping provisions***

---

### **Outline of chapter**

13.1 This chapter discusses the proposed amendments to the existing grouping provisions of the ITAA 1997 and ITAA 1936. Subsequent legislation will include measures relating to grouping provisions applicable to wholly-owned groups. The modification or removal of these 'grouping' provisions is consequent upon the introduction of a consolidation regime for wholly-owned groups.

### **Context of reform**

13.2 As part of the introduction of the consolidation regime, *A Tax System Redesigned* recommended that all existing grouping provisions of the ITAA 1936 and the ITAA 1997 be repealed. The current provisions in effect treat wholly-owned groups as if they were consolidated by allowing tax concessions within wholly-owned groups. The intention of the proposal contained in the chapter is to allow wholly-owned groups to elect to be taxed in one of 2 ways – as a single consolidated taxpaying entity or on an individual entity basis for each member of the group. The existing hybrid and less than comprehensive arrangements as represented by the grouping provisions would be replaced by the consolidation regime. Groups who choose not to consolidate will be governed by loss integrity and anti-value shifting measures in relation to intra-group transactions.

13.3 In accordance with this policy intent, the removal of the various grouping provisions will correspond with the general introduction of the consolidation regime. Groups who are ready to consolidate from 1 July 2002 may do so and consequently the relevant grouping provisions cease to be available from that date (subject to paragraph 13.4).

13.4 The date on which the removal of grouping will come into operation will be modified in the case of some groups with SAPs to avoid imposing significant additional compliance costs on those SAP groups.

### **Summary of new law**

13.5 If a wholly-owned group makes a choice to consolidate on 1 July 2002, or on the first day of a SAP income year commencing after 1 July 2002, the grouping provisions in the existing law cease to apply from that date.

13.6 If a wholly-owned group does not make the choice to consolidate at all, the grouping provisions cease to apply as of 1 July 2002.

13.7 The removal of each of the measures mentioned in paragraph 13.8 will therefore be delayed in the case of consolidated groups with a head company with a SAP. In general, such SAP groups will retain access to the grouping concessions in the existing law until the date of consolidation, provided that the head company chooses to consolidate from the first day of their next income year commencing after 1 July 2002. This ensures that a SAP group retains access to the grouping provisions until the end of a SAP income year.

13.8 The repeal or modification of the grouping provisions will be dealt with in subsequent legislation. The forthcoming measures will address the cessation and, in relation to some SAPs, the phasing out of:

- the intercorporate dividend rebate under sections 46 and 46A of the ITAA 1936;
- the loss transfer provisions currently applying to wholly-owned groups (although loss transfers will be retained for Australian branches of foreign banks in some cases);
- CGT asset rollovers for wholly-owned groups;
- transfers of excess foreign tax credits within wholly-owned groups; and
- the grouping rules contained in the Thin Capitalisation legislation that applies to a taxpayer's first income year commencing on or after 1 July 2001.

## Comparison of key features of new law and current law

<i>New law</i>	<i>Current law</i>
Intercorporate dividend rebate will be removed.	Companies within the same wholly-owned group are entitled to an intercorporate dividend rebate for both franked and unfranked dividends.
Consolidated groups need not transfer losses within the group as losses are automatically pooled. In general, company groups that do not choose to consolidate may not transfer losses within the group.	Wholly-owned company groups are able to transfer losses within the group.
Loss transfers will only apply in certain cases to transfers involving Australian branches of foreign banks.	Loss transfer provisions for wholly-owned company groups also apply to Australian branches of foreign banks that are part of a wholly-owned company group.
CGT rollover relief will be unnecessary within a consolidated group as there will not be income tax consequences from asset movements within the group. CGT rollover relief for asset transfers within a wholly-owned group will therefore cease.	Wholly-owned groups are entitled to CGT rollover relief for asset transfers within the same wholly-owned group.
Foreign tax credits will be automatically pooled within a consolidated group. Transfer of excess foreign tax credits will not be available within a wholly-owned group that does not consolidate.	Excess foreign tax credits may be transferred between companies that are members of the same wholly-owned group.
The consolidation regime will essentially replace the grouping rules contained in the new Thin Capitalisation legislation.	Thin Capitalisation legislation that applies to a taxpayer's first income year commencing on or after 1 July 2001 contains rules applying to wholly-owned groups.

## **Detailed explanation of new law**

### **General**

13.9 The consolidation provisions will come into effect on 1 July 2002. The current grouping provisions will, in general, continue to apply until 1 July 2002. Special provisions relating to SAP groups that consolidate are discussed in paragraph 13.11. 'Grouping provisions' as referred to in this discussion are:

- intercorporate dividend rebate allowable under sections 46 and 46A of the ITAA 1936;
- loss transfer provisions in Divisions 170-A to 170-C of the ITAA 1997;
- CGT rollover for asset transfers between companies in the same wholly-owned group in Division 126-B of the ITAA 1997;
- transfer of excess foreign tax credits under section 160AFE of the ITAA 1936 between companies in the same wholly-owned group; and
- grouping provisions under the Thin Capitalisation legislation.

### **Special provision for SAP groups**

13.10 The following general rules for SAP groups will apply to all of the grouping provisions referred to in paragraph 13.9.

13.11 If a head company with a SAP chooses to consolidate on the first day of the next SAP income year commencing after 1 July 2002, the grouping provisions continue to operate until that date. If no such choice is made, the grouping provisions will cease to have effect as of 1 July 2002.

13.12 In general, those provisions are retained for the extended period for all members of the SAP group and correspondingly cease to apply to all members of the group if specified conditions are not met. The extended period applies only to a SAP group that has chosen to consolidate on the first day of the next SAP year commencing after 1 July 2002.

13.13 As discussed in paragraphs 13.16, 13.19, and 13.20, some further conditions are attached to SAP groups that wish to retain access to the intercorporate dividend rebate and loss transfer provisions for the extended period.

### ***Intercorporate dividend rebate***

13.14 The intercorporate dividend rebate under section 46 will cease to apply to dividends paid after 30 June 2002 or after the last day of the income year that contains 30 June 2002.

13.15 The intercorporate dividend rebate under section 46A will cease to apply in respect of net income derived from a dividend paid after 30 June 2002, or after the last day of the income year which contains 30 June 2002.

3.16 Further, to obtain access to the rebate for the extended period, a shareholder company must comply with the following extra conditions:

- the shareholder must become a member of a consolidated group (or MEC group) on the day on which that groups comes into existence;
- the dividend must be paid to the shareholder before the date of consolidation by a company that also became a member of the group on that date; and
- the shareholder must not have previously been a member of another consolidated group before the date of consolidation.

13.17 Removal of these provisions is consistent with the rationale that groups that do not consolidate should not retain access to concessions that are intended to be replaced by consolidation.

### ***Loss transfers***

13.18 Generally, the loss transfer provisions will cease to apply as of 1 July 2002 except in the limited circumstances described in paragraph 13.11. The provisions are:

- Subdivision 170-A of the ITAA 1997 (transfer of tax losses within a wholly-owned group);
- Subdivision 170-B (transfer of net capital losses within a wholly-owned group); and
- Subdivision 170-C (provisions which apply to transfers under Subdivisions 170-A and 170-B).

13.19 Nevertheless, members of wholly-owned SAP groups will retain access to the loss transfer provisions in their current form up to the date of consolidation, if the following conditions are satisfied:

- the group has made a choice to consolidate as from the first day of the SAP income year of the head company commencing after 1 July 2002; and
- the entity became a ‘subsidiary member’ of the consolidated group as a result of the head company’s election to consolidate. This means that if the group acquired wholly-owned subsidiaries *after* the date of consolidation, those subsidiaries are not entitled to continued access to loss transfers up until the date of consolidation.

13.20 Both of these conditions must be satisfied in relation to a particular subsidiary to retain access to loss transfers. If they are not, a group member with a SAP ceases to have access to the loss transfer provisions as of 1 July 2002.

13.21 Note that members of a group whose date of consolidation is delayed because the head company has a SAP are also entitled to continued access to the grouping provisions regardless of whether those members are ordinary balancers or also have SAPs. For example, an ordinary balancer may continue to receive or transfer a loss after 30 June 2002 up until the date of consolidation as determined by the SAP period of the head company. This will also be the case for group members with a SAP which is not the same SAP period as the head company.

*Apportionment rules*

13.22 Apportionment rules will be developed according to the categories and proposals in Table 13.1.

**Table 13.1**

SAP groups who do not make a choice to consolidate.	These groups will be required to apportion on the basis of rules similar to those contained in the December 2000 exposure draft – that is, based broadly on the portion of an income year falling before 1 July 2002 and the gain or loss position of the company as at that date.
SAP or ordinary balancers whose consolidation date is delayed by the SAP of the head company.	Provided that the head company makes a choice to consolidate on the first day of its SAP income year after 1 July 2002, group members who are ordinary balancers (or members with a SAP that differs from that of the head company) are entitled to retain access to loss transfers up until that date of consolidation. This means that apportionment rules will apply to the period of that member’s income year that continues up until the date of consolidation.



SAP groups who consolidate on 1 July 2002 or on any date thereafter before the start of the head company's next SAP income year.	SAP groups may nevertheless choose to consolidate on 1 July 2002 on any date thereafter before the first day of the next SAP income year of the head company. In that event, apportionment rules will apply to losses transferred up until that date.
SAP groups who consolidate on any day after the start of the head company's SAP income year commencing after 1 July 2002 (but not on that day).	These groups do not retain access to the extended loss transfer provisions as they have not made a choice to consolidate from the first day of the head company's next SAP income year. Accordingly, loss transfers will be apportioned on the basis of the portion of an income year falling before 1 July 2002 and the gain or loss position of the company as at that date.
Groups with an ordinary balancing head company but with SAP subsidiary members, who consolidate on 1 July 2002.	Subsidiary members of the group with SAPs will be required to apportion on the basis of rules similar to those contained in the December 2000 exposure draft.

### ***Retention of loss transfers for foreign banks***

13.23 Australian branches of foreign banks will retain the ability to transfer losses with resident subsidiaries in the same wholly-owned group. Rules to give effect to this are still being developed.

13.24 Loss transfer will only be available where the wholly-owned resident subsidiaries of the foreign bank form a consolidated group (unless there is only one such subsidiary). The losses able to be transferred between the branch and the group will be determined on a basis consistent with the current tests for transferability of losses and the new rules governing the treatment of losses within a consolidated group.

### ***CGT asset rollover***

13.25 CGT asset rollover relief under Subdivision 126-B of the ITAA 1997 will cease to apply to transfers of assets between resident companies in a wholly-owned group, as of 1 July 2002. Again, these measures will be extended in the case of SAP groups who choose to consolidate on the first day of the next SAP income year commencing after 1 July 2002.

13.26 As recommended in *A Tax System Redesigned*, CGT asset rollover relief will be retained for wholly-owned groups where assets are transferred between:

- non-resident companies; or
- a non-resident company and the head company of a consolidated group.

13.27 Rules to give effect to this are still being developed. The rules will include provisions to ensure that this CGT rollover cannot be used to circumvent the cessation of CGT rollover relief for asset transfers between resident companies.

***Transfer of excess foreign tax credits***

13.28 Section 160AFE of the ITAA 1936 will be repealed to the extent that it deals with transfers of foreign tax credits between members of a wholly-owned group. This section currently provides that excess foreign tax credits may be transferred between companies within the same wholly-owned company group. As indicated previously however, companies within a wholly-owned group which consolidates on the first day of the head company's next SAP income year commencing after 1 July 2002 will retain access to these transfers until the date of consolidation.

## **Application and transitional provisions**

13.29 In general, from 1 July 2002 these amendments remove the grouping provisions in the existing law for wholly-owned groups. For wholly-owned groups with SAPs, the grouping provisions in the existing law will instead cease to apply from the start of a group's first SAP income year commencing after 1 July 2002.

## **Consequential amendments**

13.30 Amendments consequential to the removal or modification of the various grouping provisions will be included in subsequent legislation.

---

# ***Index***

---

**Schedule 1: [Click here and insert Schedule name]**

<i>Bill reference</i>	<i>Paragraph number</i>

**Schedule 2: [Click here and insert Schedule name]**

<i>Bill reference</i>	<i>Paragraph number</i>

**Schedule 3: [Click here and insert Schedule name]**

<i>Bill reference</i>	<i>Paragraph number</i>

**Schedule 4: [Click here and insert Schedule name]**

<i>Bill reference</i>	<i>Paragraph number</i>

**Schedule 5: [Click here and insert Schedule name]**

<i>Bill reference</i>	<i>Paragraph number</i>

**Schedule 6: [Click here and insert Schedule name]**

<i>Bill reference</i>	<i>Paragraph number</i>

**Schedule 7: [Click here and insert Schedule name]**

<i>Bill reference</i>	<i>Paragraph number</i>

**Schedule 8: [Click here and insert Schedule name]**

<i>Bill reference</i>	<i>Paragraph number</i>

**Schedule 9: [Click here and insert Schedule name]**

<i>Bill reference</i>	<i>Paragraph number</i>

**Schedule 10: [Click here and insert Schedule name]**

<i>Bill reference</i>	<i>Paragraph number</i>

**Schedule 11: [Click here and insert Schedule name]**

<i>Bill reference</i>	<i>Paragraph number</i>

**Schedule 12: [Click here and insert Schedule name]**

<i>Bill reference</i>	<i>Paragraph number</i>

**Schedule 13 [Click here and insert Schedule name]**

<i>Bill reference</i>	<i>Paragraph number</i>

**Schedule 14: [Click here and insert Schedule name]**

<i>Bill reference</i>	<i>Paragraph number</i>

**Schedule 15: [Click here and insert Schedule name]**

<i>Bill reference</i>	<i>Paragraph number</i>



